

SANITARY SEWER LIFT STATION AND FORCE MAIN
BOTANICA - THE WICHITA GARDENS
STREETS AND UTILITIES

LIFT STATION DETAILS
SHEET TITLE
468-84683
PROJECT NUMBER

DESIGN BY: **AJK**
DRAWN BY: **DMU**
CHECKED BY: **BLW**

ISSUED: **July 2010**
REVISED: **11/04/10**

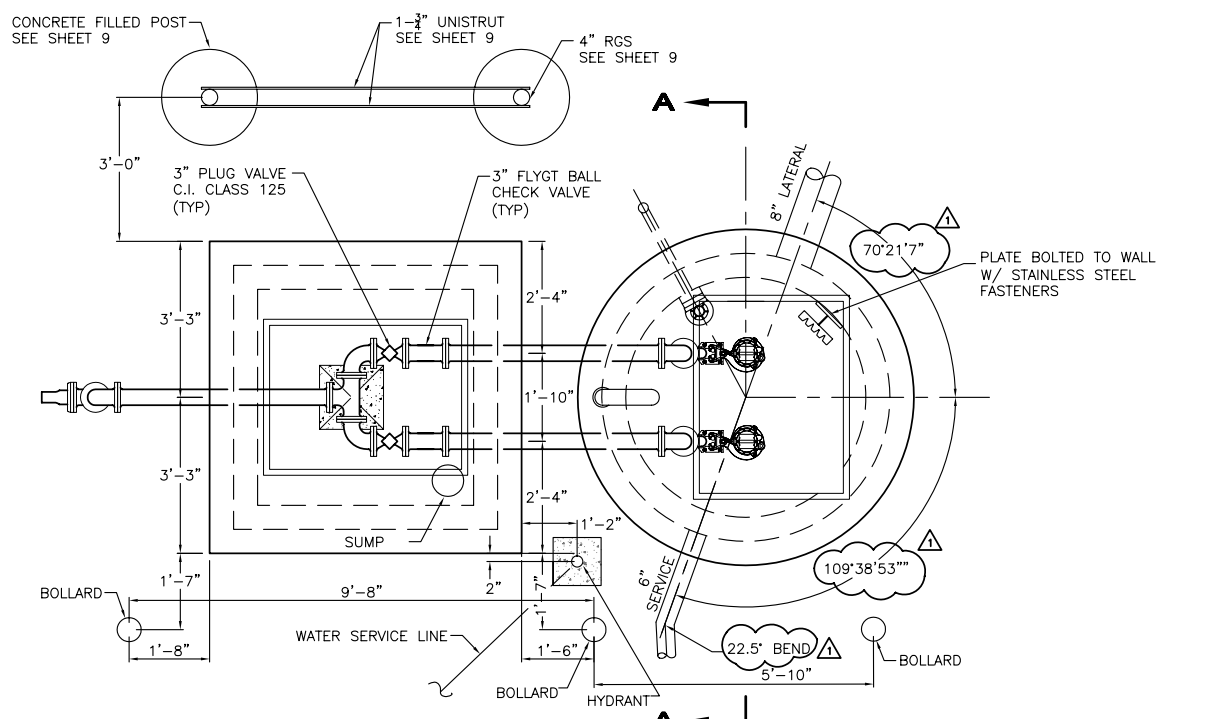

PLAN VIEW
REINFORCING NOT SHOWN FOR CLARITY.
(SEE DETAILS 1 AND 2 FOR REINFORCING)

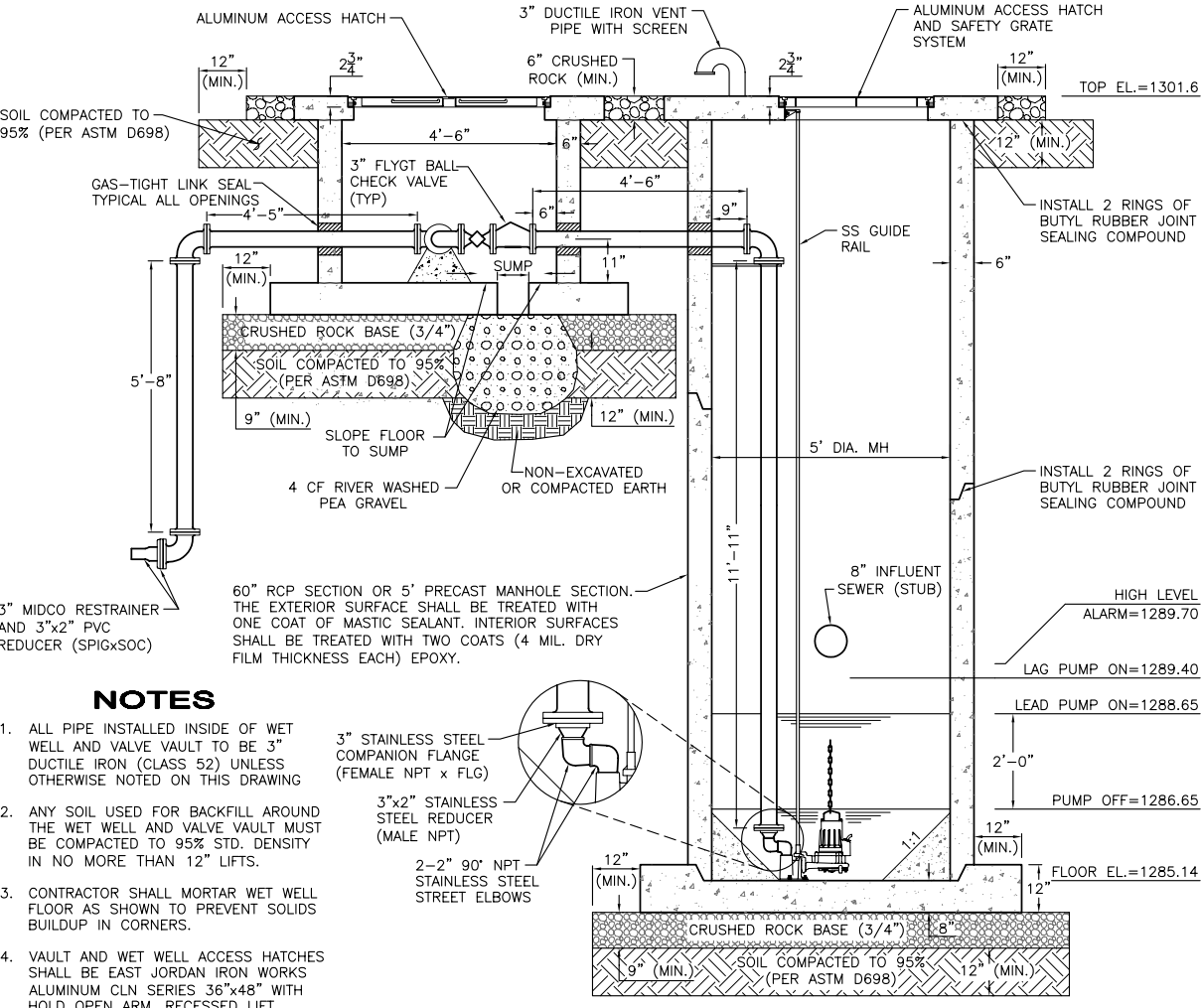

ELEVATION
LOOKING WEST
REINFORCING NOT SHOWN FOR CLARITY.
(SEE DETAILS 1 AND 2 FOR REINFORCING)

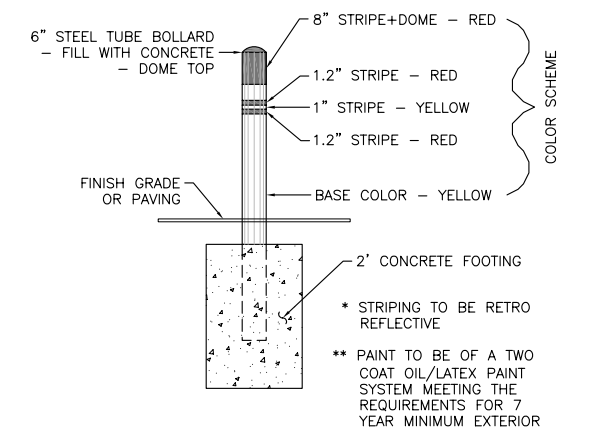

BOLLARD
NO SCALE

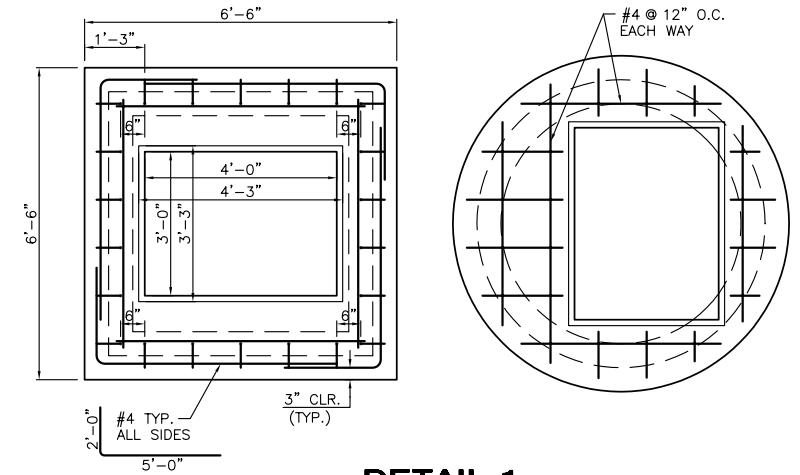

DETAIL 1
PLAN - TOP REINFORCING

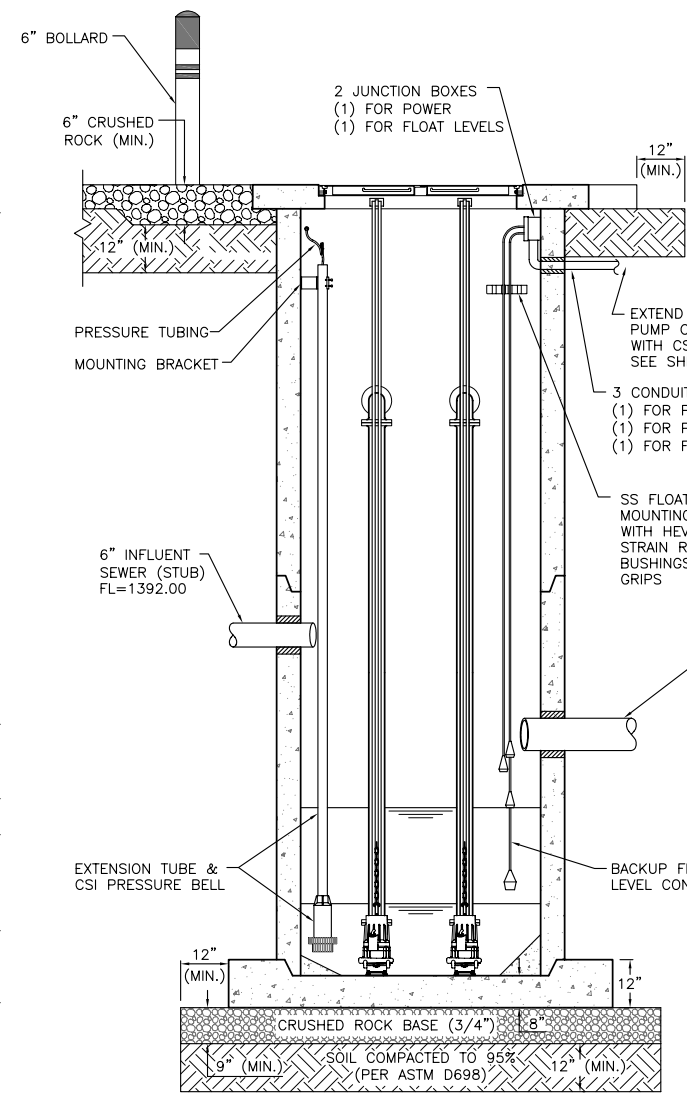

SECTION A-A
ELEVATION - LOOKING SOUTH
REINFORCING NOT SHOWN FOR CLARITY.
(SEE DETAILS 1 AND 2 FOR REINFORCING)

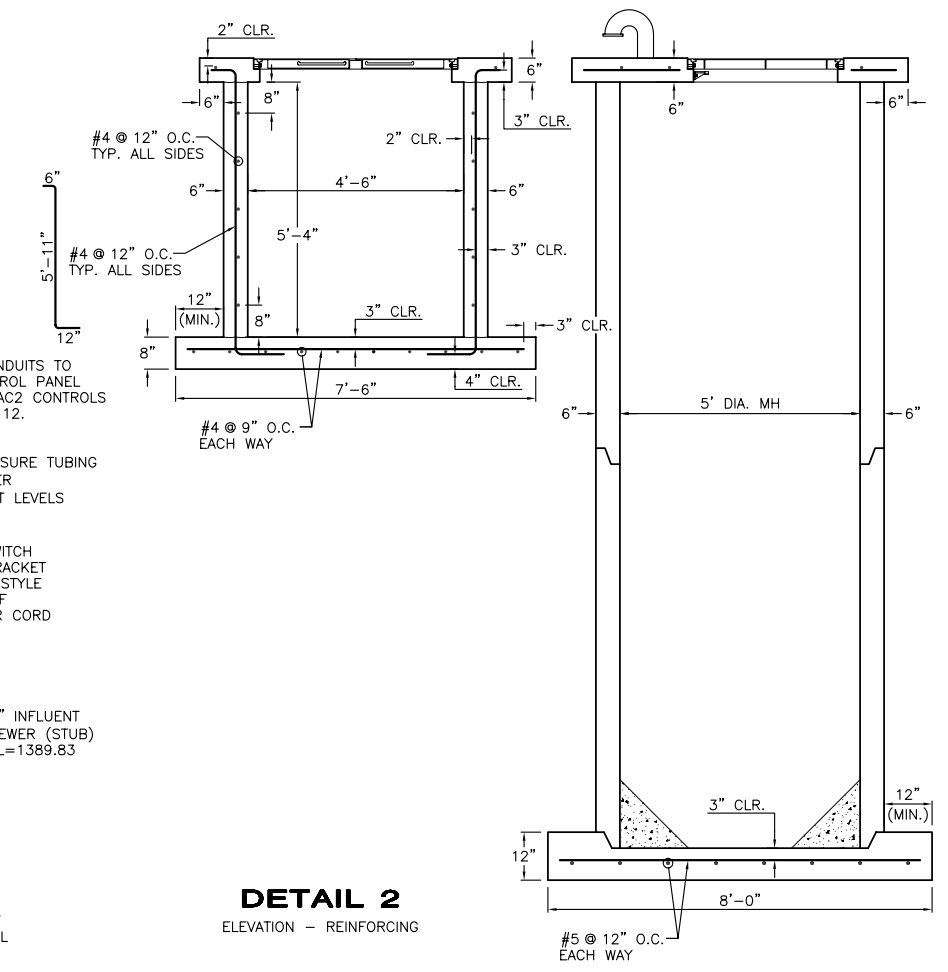

DETAIL 2
ELEVATION - REINFORCING

TYPE/MODEL	MINIMUM CAPACITY		MINIMUM CONN. SIZES		MOTOR	
	GPM	TDH(ft)	SUCTION	DISCHARGE	HP	RPM ELECT.
DUPLIX FLYGT GRINDER PUMPS MODEL MP3068-218	120	53.5	NA	2"	2.3	3325 230/60/1

THE PUMPS SHALL BE INSTALLED WITH A CSI PRESSURE ACTIVATED CONTROL (PAC 2) SYSTEM. THE PUMPS SHALL ALSO HAVE A BACKUP FLOAT LEVEL CONTROL SYSTEM.

ALL WORK ASSOCIATED WITH THIS SHEET SHALL BE SUBSIDIARY TO BID ITEM "LIFT STATION MODULE"

PLOTED: Monday, November 08, 2010 01:59PM