

| STATE | PROJECT NO. | YEAR | SHEET NO. | TOTAL SHEETS |
|--------|--------------|------|-----------|--------------|
| KANSAS | 87 N-0361-01 | 2011 | 11 | 169 |

MKEC
ENGINEERING
CONSULTANTS, INC.
411 N. WEBB ROAD
WICHITA, KS. 67206
316-684-9600

**LINCOLN STREET BRIDGE AND
DAM IMPROVEMENTS OVER
ARKANSAS RIVER**

DOWELED & CONTRACTION JOINT DETAILS
SHEET TITLE
472-84883
PROJECT NUMBER

JRA
DESIGN BY
DPG
DRAWN BY
KJS
CHECKED BY

ISSUED
1/24/2011
REVISED

SHEET NO.
11 of 169

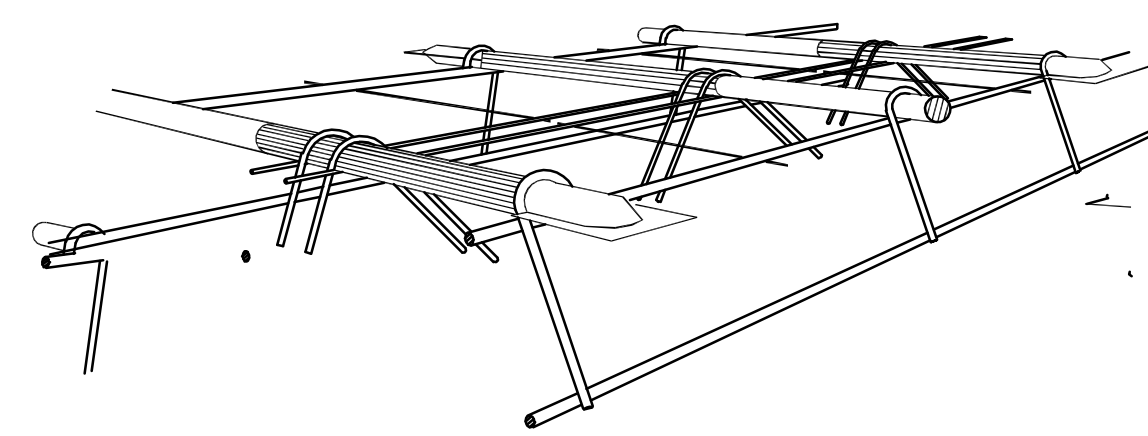

PERSPECTIVE VIEW

Note: Wire sizes shown are minimum required.
Sides held together with tie wire, allowing quick separation of sides & insertion of expansion material, provided in field.
One length of Preformed Expansion Joint filler (Type B), or other approved material, cut to fit crown and subgrade shall be used for each lane of pavement as expansion joint filler.
A string line shall be stretched between the pavement forms along the center line of the joint.
Each dowel bar shall be coated with an epoxy coating with the average film thickness of not less than 10 mils on any bar, with individual determinations within a tolerance of ± 3 mils of the average. The coating need not be applied to the end faces of the bars and will not be required within 2 inches of the end which will be fixed in the supporting basket by welding. The coating material shall be a powdered epoxy resin approved by the Engineer of Materials and shall be uniformly applied according to accepted practices and the resin manufacturer's recommendations.

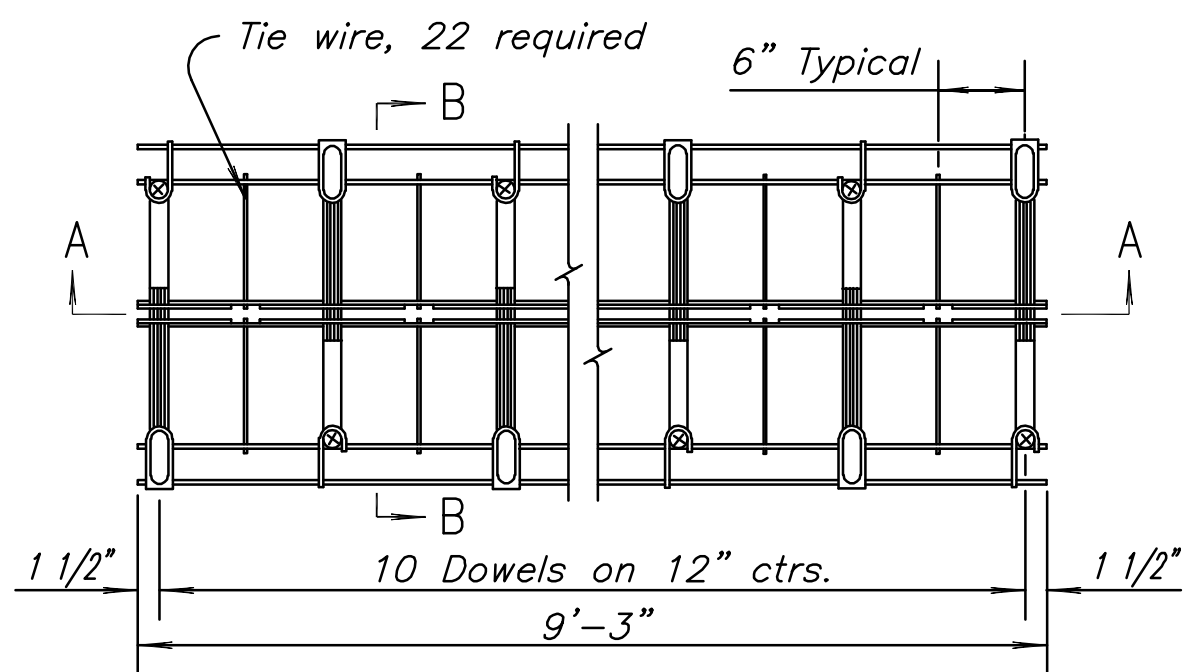

PLAN VIEW

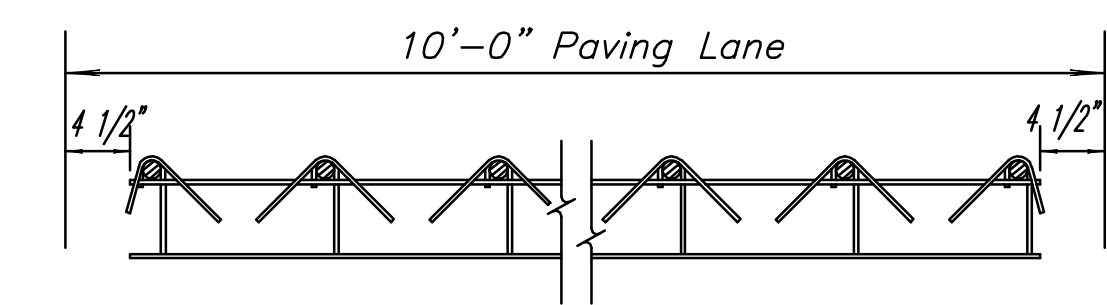

SEC. A-A

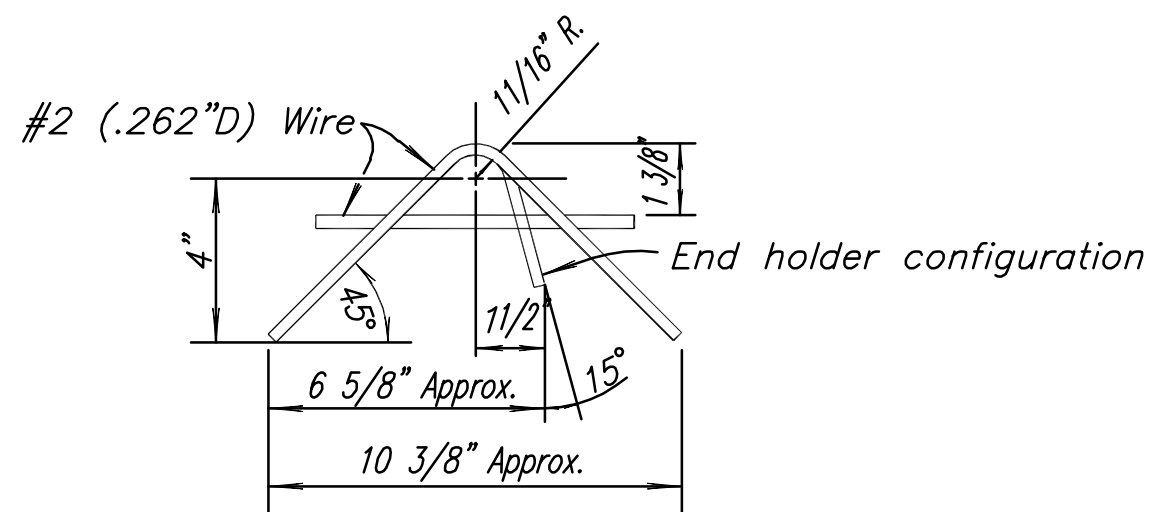

* See pavement details for size of dowels.

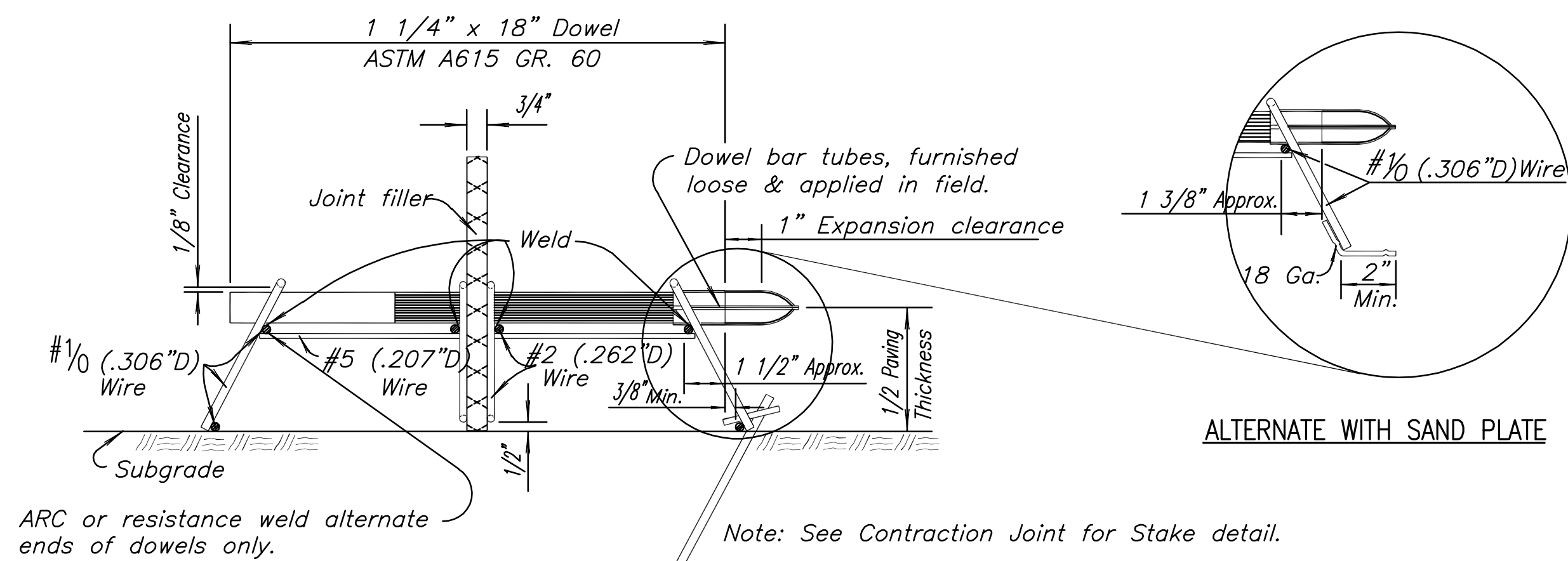

SEC. B-B

DOWELED ISOLATION JOINT

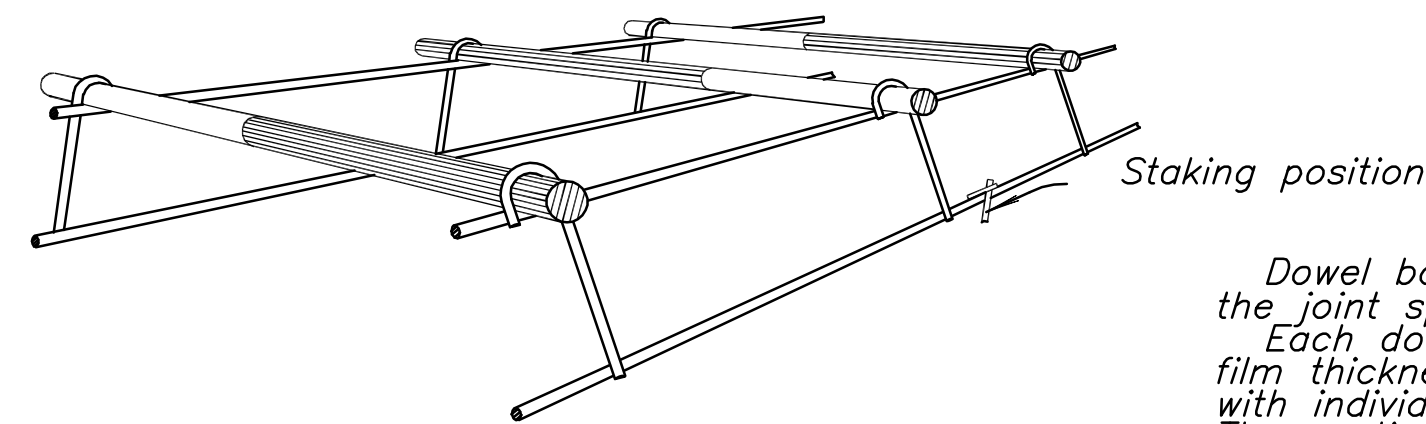

PERSPECTIVE VIEW

Staking position

GENERAL NOTE
Dowel bar insertion may be by mechanical dowel placers regardless of the joint spacing.
Each dowel bar shall be coated with an epoxy coating with the average film thickness of not less than 10 mils on any bar exclusive of end faces, with individual determinations within a tolerance of ± 3 mils of the average. The coating material shall be a powdered epoxy resin approved by the Chief, Bureau of Materials and Research and shall be uniformly applied according to accepted practices and the resin manufacturer's recommendations. For Alt. 1 the coating need not be applied to the end faces of the bars and will not be required within 2 inches of the end which will be fixed in the supporting basket by welding.
The cutting to length of the dowel bars shall be done in such a manner to result in no appreciable deformation of the ends.

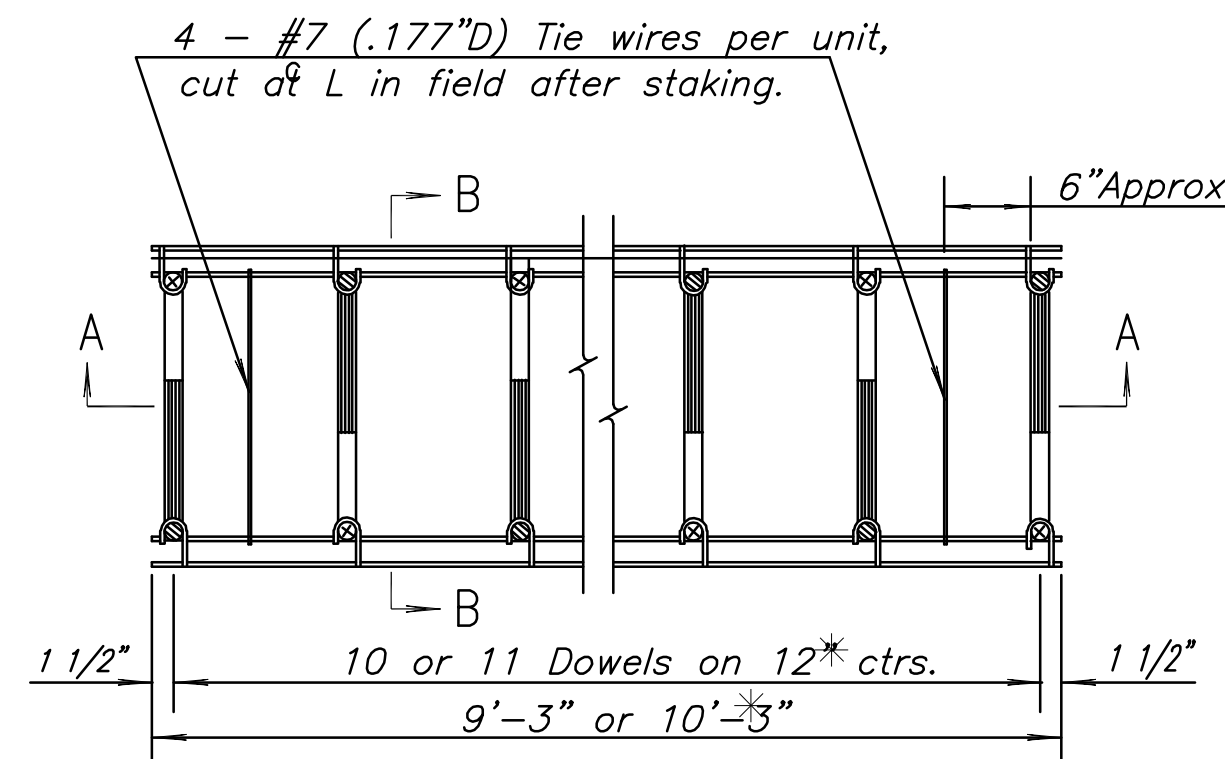

PLAN VIEW

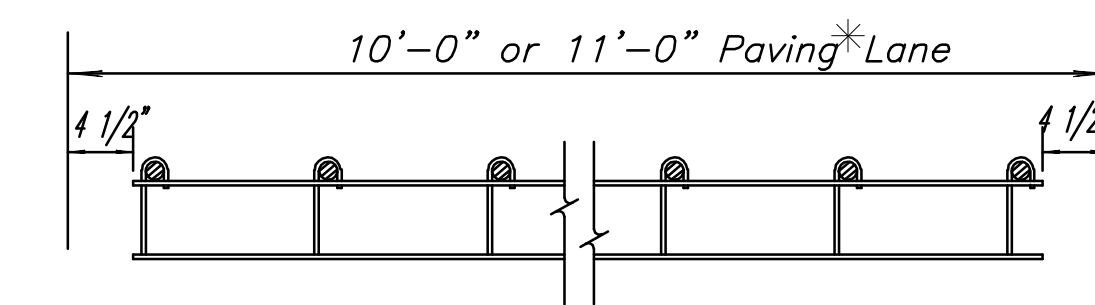

SEC. A-A

* Adjust as necessary depending on lane width

Dowel assemblies are to be adjusted as required in tapered sections.

Alt. 1 (Baskets)
Wire sizes shown are minimum required.
Basket to be staked to sub-grade, as shown. Ramset or similar type fastener with clip to be used when subgrade condition requires it.
A string line shall be stretched between the pavement forms along the center line of the joint. The position of the joint shall be carefully marked so that the saw cut will coincide with the center line of the joint.
In order to identify the location of the bond breaker application, the working end of dowel and the supporting leg shall receive a light application of red paint at the place of fabrication. The bond breaker to be applied in the field prior to concrete placement shall consist of coating approximately three-fifths of the length of each dowel bar with hard grease at the working end identified by the red paint.
The entire joint assembly shall be carefully leveled so that the dowels are parallel to the slab surface and free to slide in the dowel holders. Any coating scraped off the dowels in assembling the joint shall be replaced.
After the complete contraction joint is assembled, it shall be checked to be certain that the vertical plane of the joint will be perpendicular to the finished surface of the slab and at a right angle with the center line of the slab unless shown otherwise on the plans. The dowels shall be checked to be certain that they are level and will remain in a position parallel with the finished surface of the slab.
Concrete shall be placed over and adjacent to the joint in accordance with the requirements of the Specifications.
Other approved designs may be used in lieu of the type shown.

Alt. 2 (Mechanical placement)
Joint spacing shall be normal to centerline.
The pavement shall be placed and consolidated to full depth prior to insertion of the dowel bars.
The dowel bars shall be coated with a bond breaking agent prior to insertion into the plastic concrete.
The dowel bars shall be inserted into the plastic concrete ahead of the finishing beam or screed.
The installing device shall consolidate the concrete around the dowel bars such that no voids exist, without the supplemental use of hand held vibrators.
The dowel bars shall be located within one inch of the planned transverse location and within the range of depth of $D/4$ from mid depth and mid length of the bar where D is the planned pavement thickness.
The dowel bars shall be located within two inches of the planned longitudinal location.
The dowel bars shall be parallel to the pavement surface and centerline within a tolerance of one half inch in 18 inches in both the vertical and horizontal direction.
The forward movement of the finishing beam or screed shall not be interrupted by the inserting of the dowel bars.
A positive method of marking the locations of the transverse joints shall be provided.

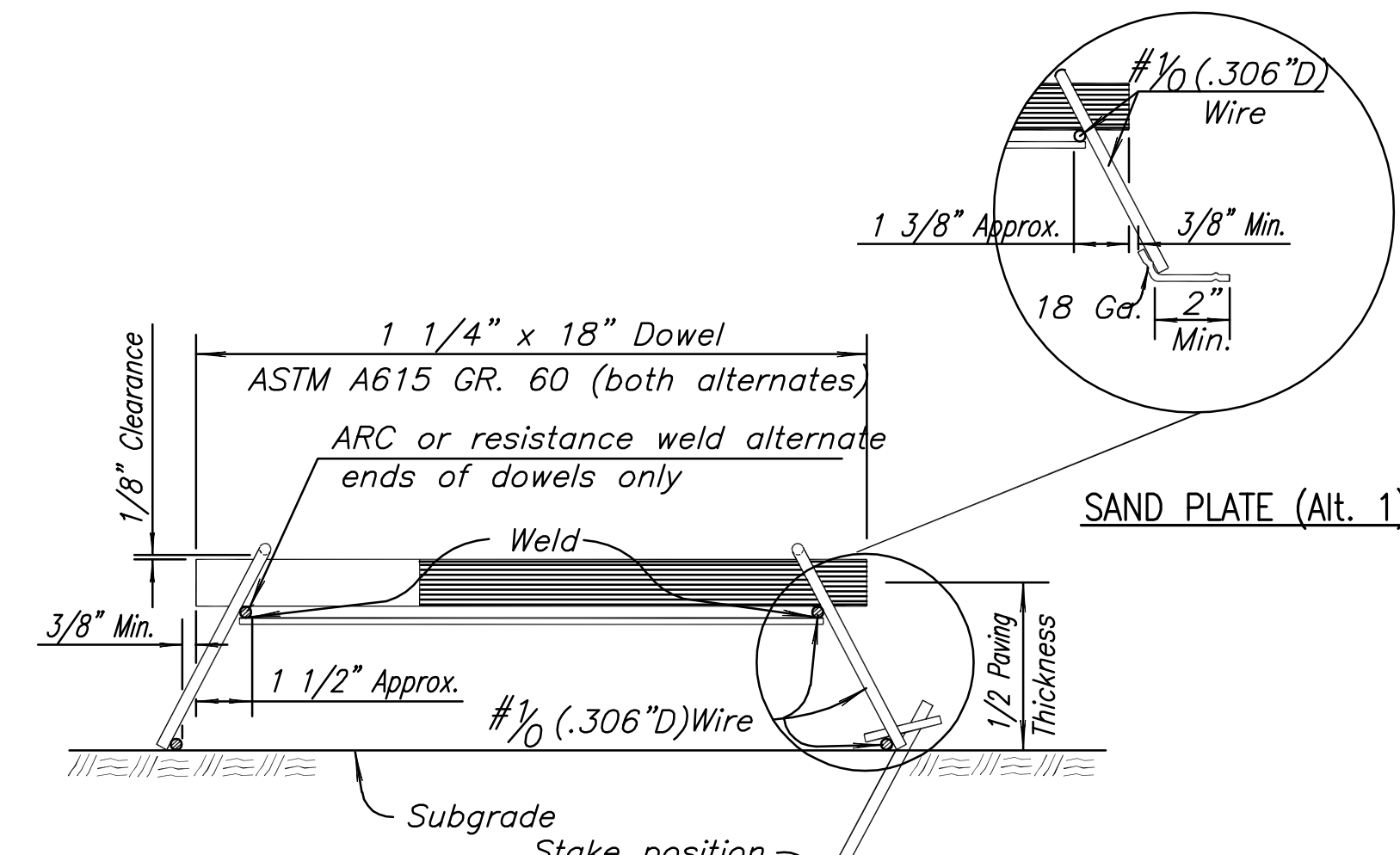

SEC. B-B

CONTRACTION JOINT

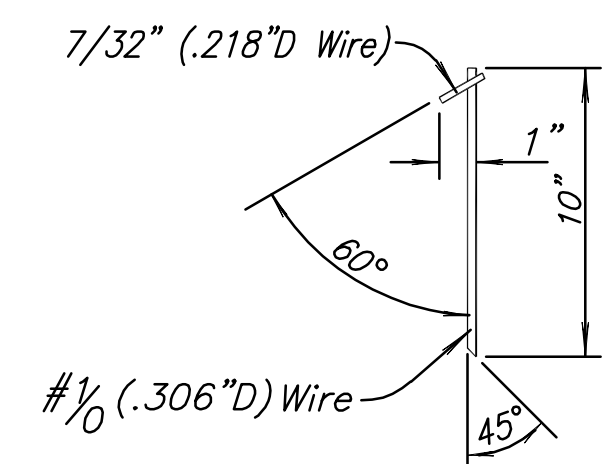

STAKE DETAIL
(6 Pieces minimum required)