

TYPICAL SECTION  
COMBINED CURB & GUTTER - TYPE I (2'-6" WIDTH)

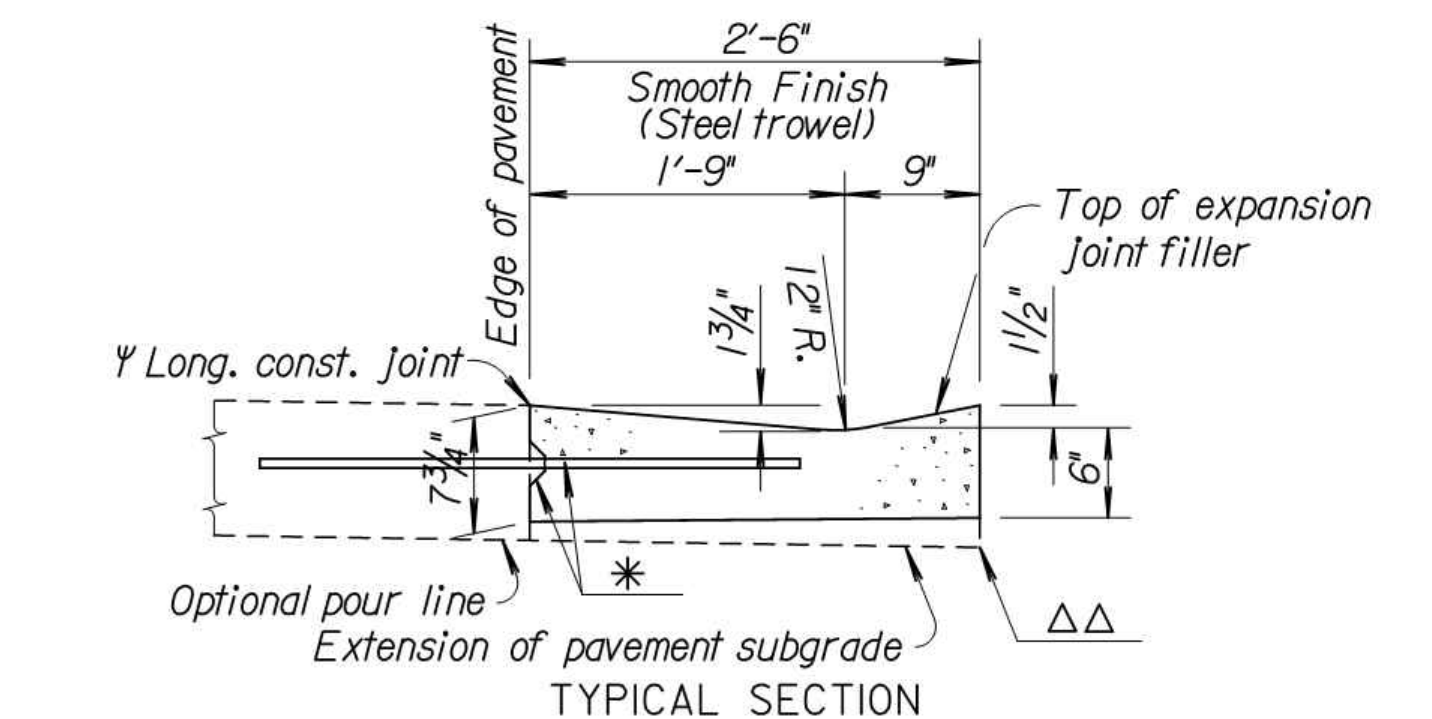

TYPICAL SECTION  
COMBINED CURB & GUTTER - TYPE II (2'-6" WIDTH)

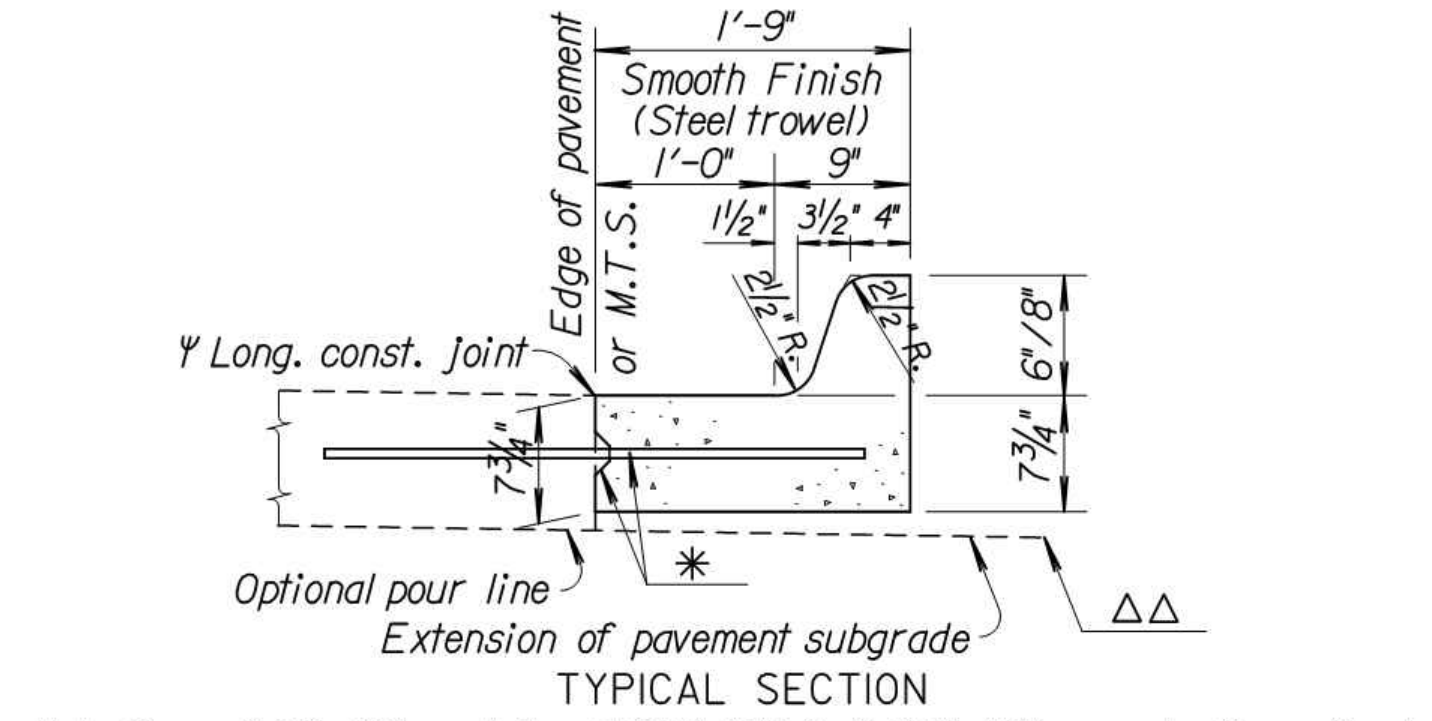

TYPICAL SECTION  
COMBINED CURB & GUTTER - TYPE III (1'-9" WIDTH)

\* Longitudinal construction joint and #4 x 3'-0" bars @ 2'-6" ctrs., where concrete pavement is constructed.

△△ Contractor has the option of thickening the curb and gutter as shown.

Note: Use Concrete Grade 3.0 (AE) throughout. All exposed edges shall be finished with an edging tool. Place a 1" Preformed Expansion Joint Filler (Nonextruding, Type B) at a spacing not to exceed 250'.

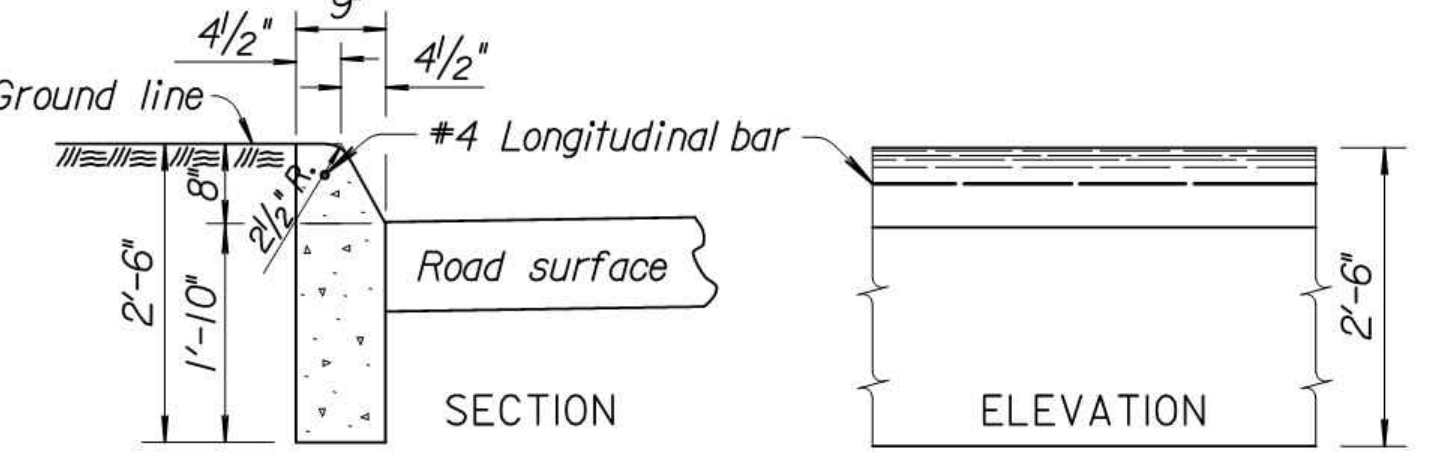

PROTECTION CURB 8"

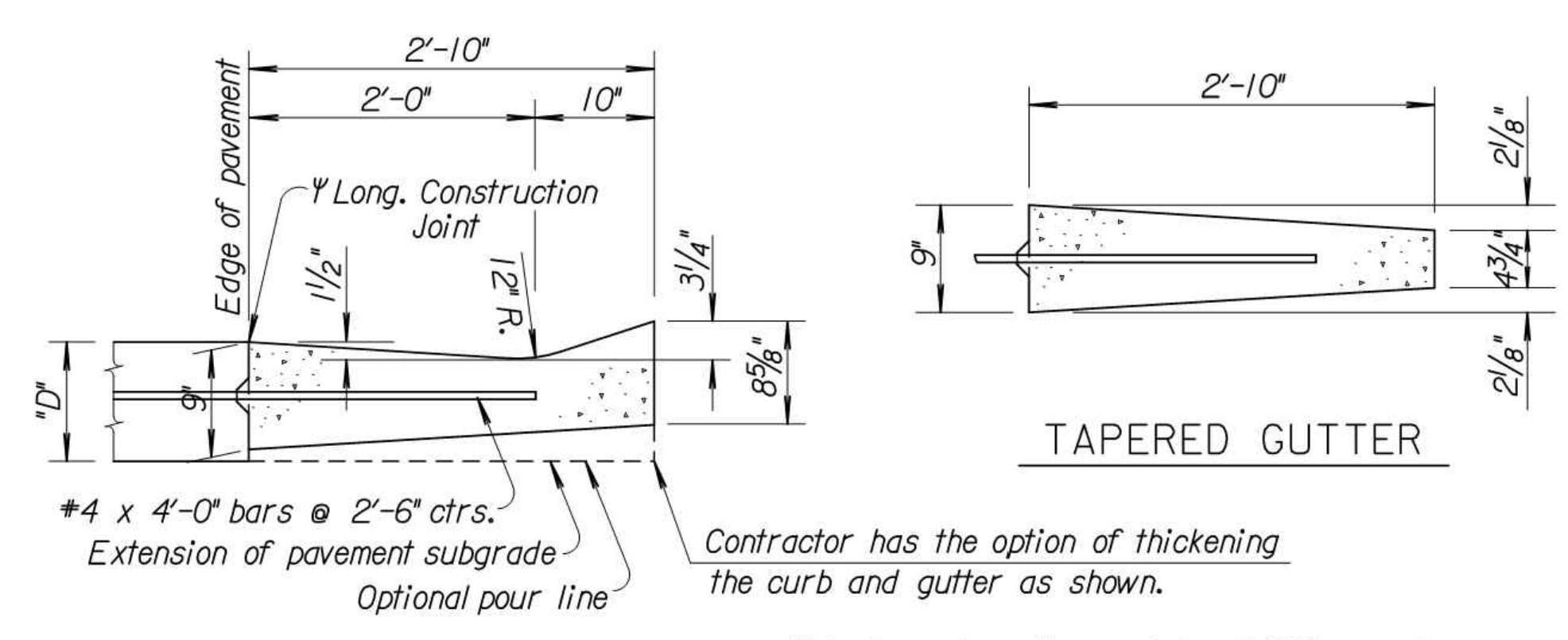

DETAIL OF GUTTER (Normal section)

Note: Concrete gutter contains 0.065 cu. yds. Concrete Grade 3.0 (AE) per lin. ft..

GUTTER

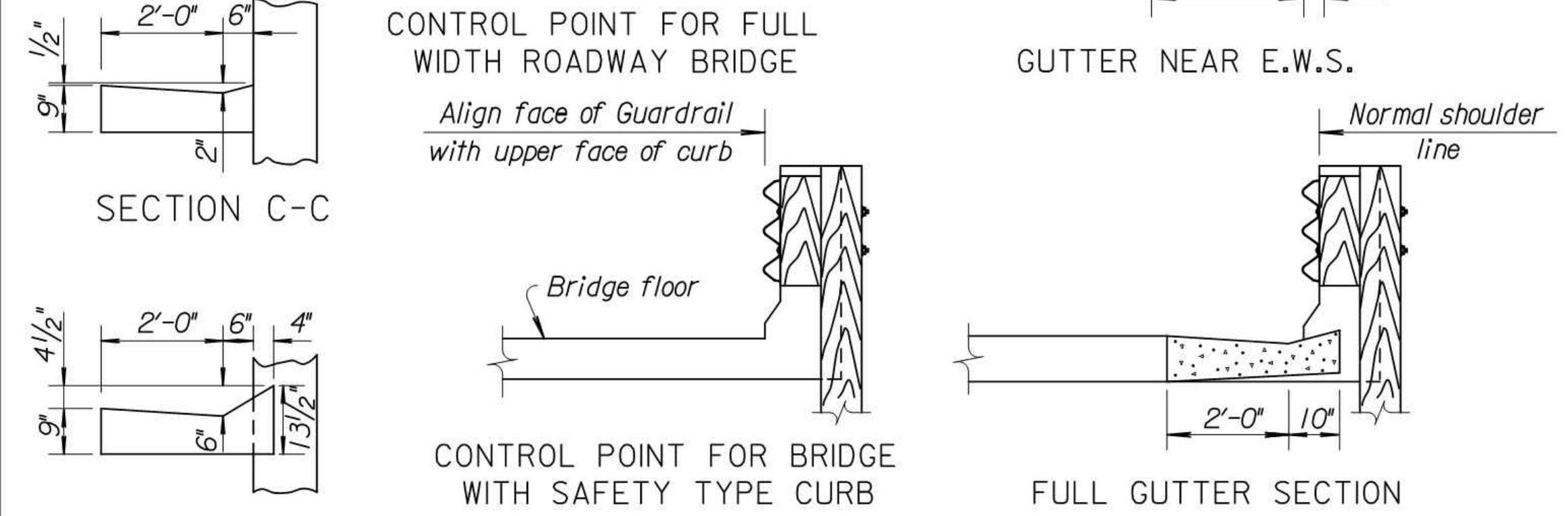
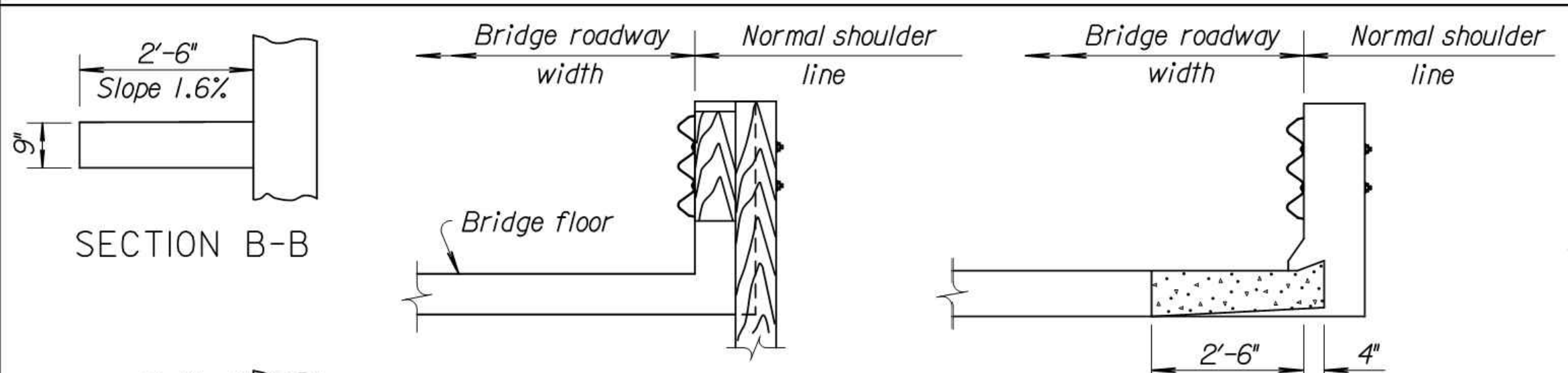

☆ At locations where the centerline grade is relatively flat and the pavement grade is such that the gutter will direct drainage onto the bridge, the flowline depth may be reduced as directed by the Engineer to facilitate drainage.

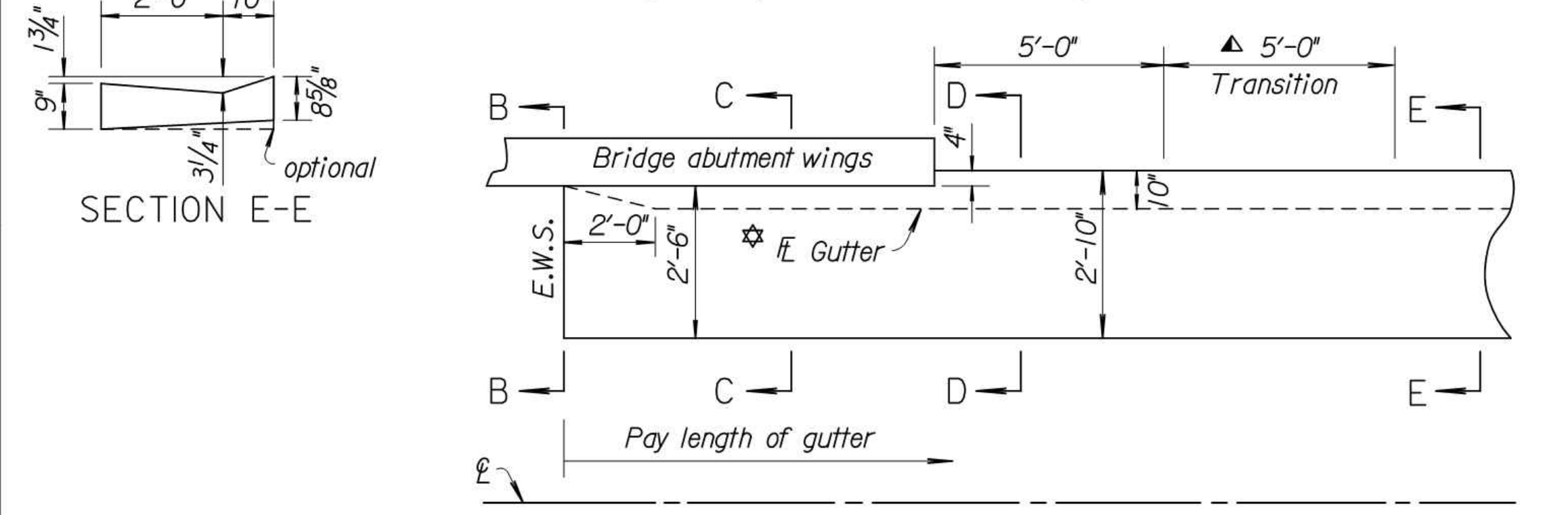

TYPICAL GUTTER @ BRIDGE ENDS (Drawn for down grade end and "U" Type Abutments)

Note: Shaping of gutter is to be Subsidiary to "Gutter (AE)".  
▲ Transition gutter to standard 2'-10" gutter section.

FOR RETROFIT OF BRIDGE APPROACHES WITH GUTTER

**GENERAL NOTE**

Combined curb and gutter or gutter adjoining concrete pavement may, at the contractor's option, be constructed either monolithically or separately, using either the mix used in the concrete pavement or Concrete Grade 3.0 (AE). The combined curb and gutter or gutter shall have the same section as shown on the plans. If constructed monolithically, the longitudinal joint and dowel bars shall be omitted from the combined curb and gutter or gutter. Pavement joints shall be continued through curb or gutter and no other planes of weakness will be required. Joints in the combined curb and gutter are to be filled with the same material as used for the pavement joints.

Expansion joints in the combined curb and gutter are to be placed opposite expansion joints in the pavement.

Where combined curb and gutter or gutter does not abut concrete pavement or concrete base course, omit tie bars and place a 1" Preformed Expansion Joint Filler (Type B) cut to the dimensions of the combined curb and gutter or gutter, at a spacing not to exceed 250' and at the ends of curb returns. Planes of weakness shall be constructed at 10'-0" intervals.

A 4' length of transition from normal gutter section to the tapered gutter section shall be used at the ends of each run of gutter except where the gutter abuts a curb, such as at the end of a bridge. Inlets shall be located so as not to fall within this transition section.

Where pressure relief joint is placed across the pavement, and gutter or curb and gutter is continued on for more than 10', use 4"x4" membrane sealant installed with bonding adhesive through gutter section, shaped to fit gutter or curb and gutter. See Std. Drawing RD712.

For expansion joint treatment where combined curb and gutter or gutter abuts a bridge wing on a U-type abutment see bridge drawings.

Longitudinal joints shall be sawed and sealed with joint sealant, see Standard Specifications.

ψ If constructed monolithically, the longitudinal joint is not required.

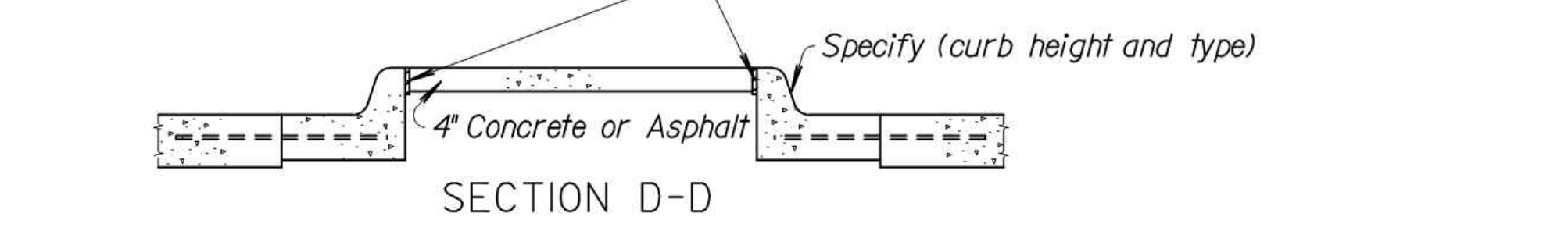
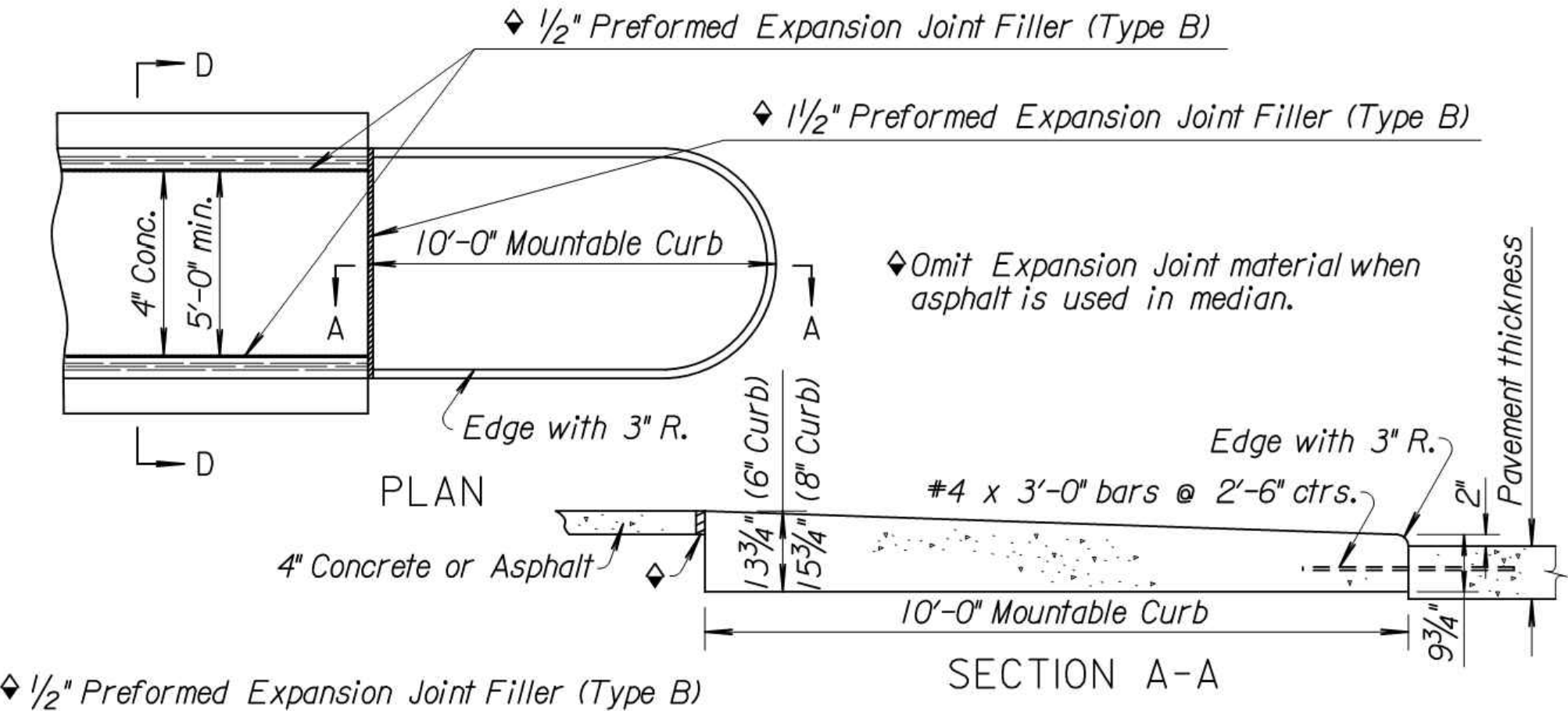

Note: Expansion joints shall be placed in concrete median as follows. In long runs expansion joints shall be 1/2" Preformed Expansion Joint Filler (Type B) installed flush with the surface. Expansion joints in the median shall match expansion joints in the curb and gutter with a maximum spacing of 125'. Plane of weakness in the median shall match plane of weakness in curb and gutter.

TYPICAL NOSE DETAILS FOR RAISED MEDIANS

Note: Additional Concrete Grade 3.0 (AE) needed to complete median nose shall be subsidiary to the bid item "Combined Curb & Gutter".

NO.	DATE	REVISIONS	BY	APP'D
17	7-2-09	Rev. nose details, jt. sealant & retro.	S.W.K.	J.O.B.
16	1-10-07	Changed bituminous to asphalt	S.W.K.	J.O.B.
15	3-30-05	Chg. Class to Grade conc., reinf.	S.W.K.	J.O.B.
14	12-08-04	Chg. bit. plane of weakness to 10'-0"	S.W.K.	J.O.B.

KANSAS DEPARTMENT OF TRANSPORTATION

**CURB, GUTTER AND COMBINED CURB & GUTTER**

RD635

FHWA APPROVAL	12-18-09	APP'D. James O. Brewer
DESIGNED	DETAIL	QUANTITIES
DESIGN CK.	DETAIL CK.	QUAN. CK.

Traced by: Bowser  
Trace CK: King

CENTRAL AVENUE  
ROCK ROAD TO WEBB ROAD  
KDOT STANDARD - R0635  
CITY OF WICHITA, KANSAS  
JAMES L. ARMOUR, P.E. - CITY ENGINEER

POE & ASSOCIATES, INC.  
CONSULTING ENGINEERS  
5940 E. Central, Suite 200 • Wichita, KS 67208-4242  
Phone 316/685-4114 • FAX 316/685-4444

Engineer: P. FERUGSON  
Designer: P. FERUGSON/M. TUCKER  
Poe Job No.: 1972  
Date: MARCH 2011

Sheet 9 of 69