

- GENERAL NOTES**
1. USE THE CONCRETE MIX SPECIFIED FOR THE CITY OF WICHITA CONCRETE PAVEMENT THROUGHOUT. ALL EXPOSED EDGES SHALL BE FINISHED WITH AN EDGING TOOL. REINFORCING BARS SHALL BE BENT AROUND PIPE.
  2. INLET INVERT SHALL BE SHAPED WITH 8 SACK MIX CONCRETE TO CREATE FLOW CHANNELS AND TO INCREASE HYDRAULIC EFFICIENCY SUCH THAT THE INLET WILL BE SELF CLEANING BETWEEN ALL INLET AND/OR OUTLET PIPES.
  3. ALL BARS ARE #4 WITH 6" SPACING AND SHALL HAVE A MINIMUM CLEARANCE OF 1 1/2 INCHES UNLESS OTHERWISE NOTED ON THE PLANS.
  4. WHEN DIRECTED BY THE ENGINEER, A SMALL OPENING MAY BE REQUIRED IN THE BACK OF THE INLET IN ORDER TO DRAIN A LOW AREA. REINFORCING BARS WILL EXTEND THROUGH THE OPENINGS. NO DEDUCTIONS IN CONCRETE QUANTITIES WILL BE MADE FOR THESE OPENINGS.
  5. NO DEDUCTIONS WILL BE MADE IN PAY LENGTH OF CURB, GUTTER, OR CURB AND GUTTER THROUGH THE INLET AREA.
  6. USE DEETER FOUNDRY, INC. CASTING NO. 2442/43 OR EJIW 7600Z LEFT SIDE, 7600 RIGHT SIDE IN INLET FRAME AND GRATE WITH STYLE H GRATE. INLET FRAME TO BE PROOF LOAD TESTED TO 40,000 LBS. ON UNSUPPORTED SIDE.
  7. REINFORCING BARS SHALL BE CUT OR BENT AROUND PIPES. NO DEDUCTION IN CONCRETE QUANTITIES SHALL BE MADE FOR PIPE OPENINGS.
  8. THE VANES OF THE GRATE SHALL BE ORIENTED WITH RESPECT TO THE FLOW ARROWS SHOWN ON THE PLANS.
  9. CONTRACTOR SHALL REMOVE LIFTING HOOKS AFTER INSTALLATION. RECESSES IN INLET WALL SHALL BE GROUTED FLUSH TO THE INLET WALL WITH HYDRAULIC CEMENT AFTER THE INLET IS IN PLACE. LIFTING HOLES THRU THE INLET WALL WILL NOT BE ACCEPTED.

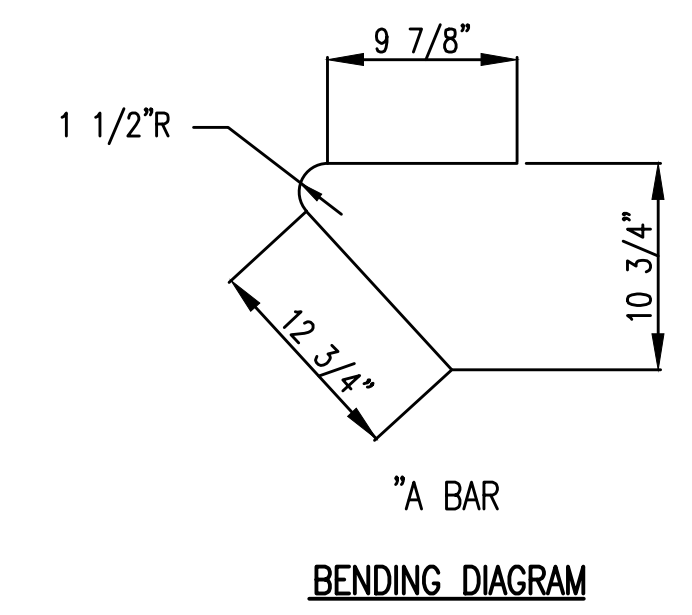

**STANDARD SINGLE TYPE II CURB INLET**

CITY ENGINEER  
**JAMES L. ARMOUR, P.E., L.S.**

PROJECT NUMBER	OCA NUMBER	DATE
		11/2010

CITY ENGINEER'S OFFICE  
CITY HALL - SEVENTH FLOOR  
455 NORTH MAIN STREET  
WICHITA, KANSAS 67202-1620  
(316) 268-4501

DESIGN	DRAWN

SHEET  
- of -

No.	Date	By	Approved	Revision

CENTRAL AVENUE  
ROCK ROAD TO WEBB ROAD  
STORM SEWER DETAILS  
CITY OF WICHITA, KANSAS  
JAMES L. ARMOUR, P.E. - CITY ENGINEER

POE & ASSOCIATES, INC.  
CONSULTING ENGINEERS  
5940 E. Central, Suite 200 • Wichita, KS 67208-0242  
Phone 316/605-4114 • FAX 316/605-4444

Engineer: P. FERGUSON  
Designer: P. FERGUSON/M. TUCKER  
Poe Job No.: 1972  
Date: MARCH 2011

Sheet  
14 of 69