

POWER POLE DETAILS

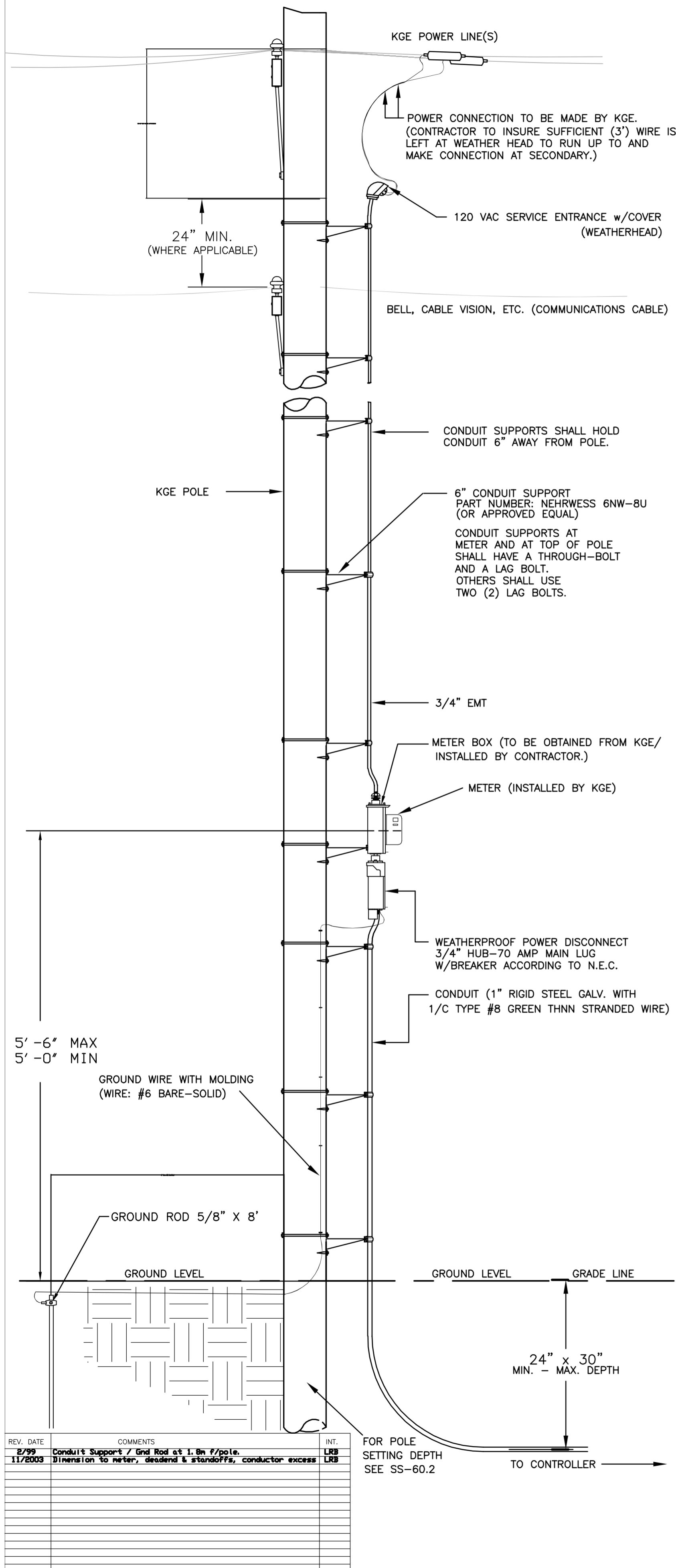

REV. DATE	COMMENTS	INT.
2/99	Conduit Support / Gal Rod at 1.5m #/pole.	LIB
11/2003	Dimension to meter, descend & standoffs, conductor excess	LIB

SPANWIRE ASSEMBLY DETAILS

1. MAX. SAG = 5% OF SPAN.
2. STANDARD BACKRAKE = 1.5'
3. HEIGHT OF STRAIN WIRE HOOK-UP TO BE DETERMINED BY FIELD ENGINEER. TRAFFIC SIGNAL CABLE TO BE SECURED TO STRAIN (SPAN) WIRE WEATHERABLE NYLON CABLE HANGERS (12" CTR.) DETAIL 'B'
4. TETHER CLAMP TO BE DESIGNED TO RELEASE UNDER 'HIGH WIND LOAD' TO PERMIT SIGNAL 'FREE SWING'.

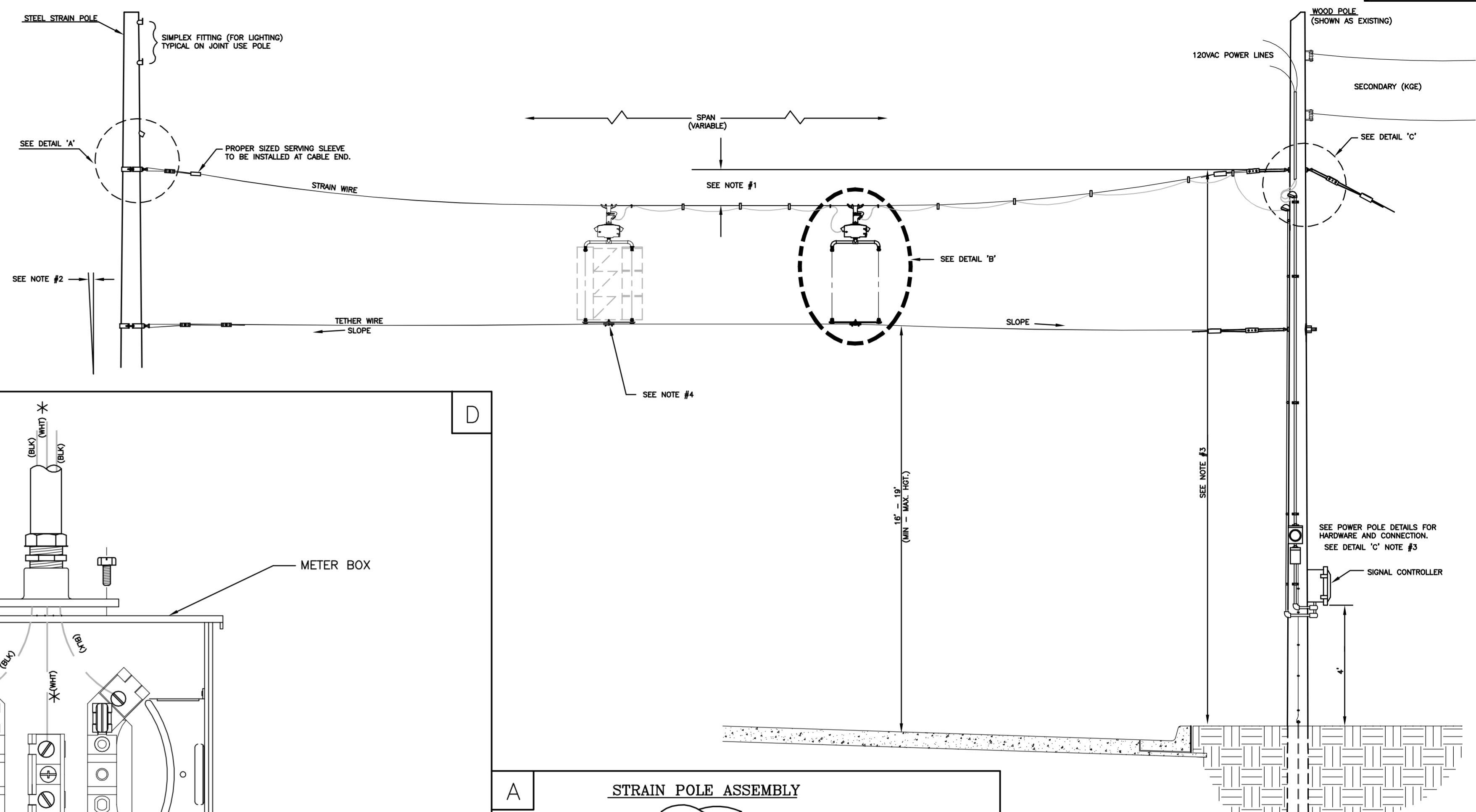

METER BOX & POWER DISCONNECT DETAILS

NOTE:
* TO BE MARKED WITH WHITE TAPE

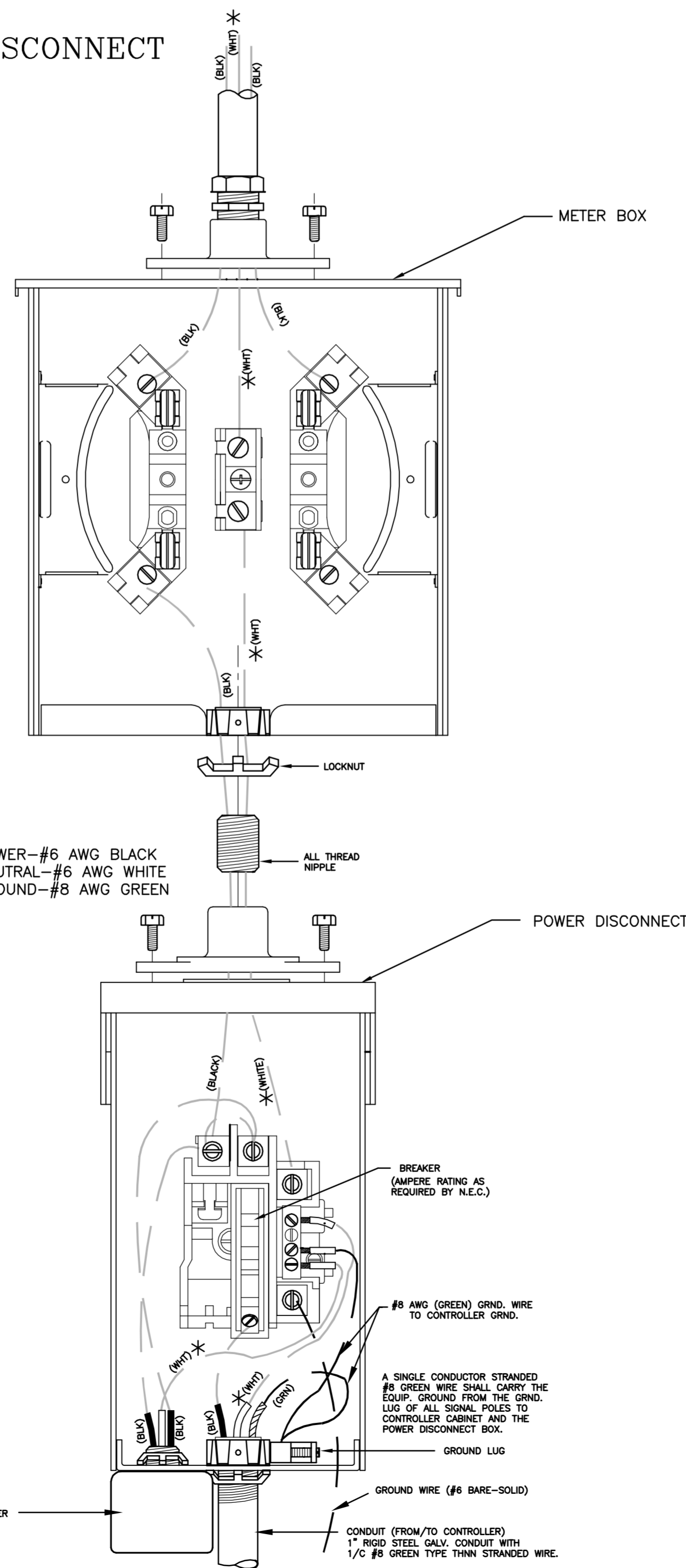

A STRAIN POLE ASSEMBLY

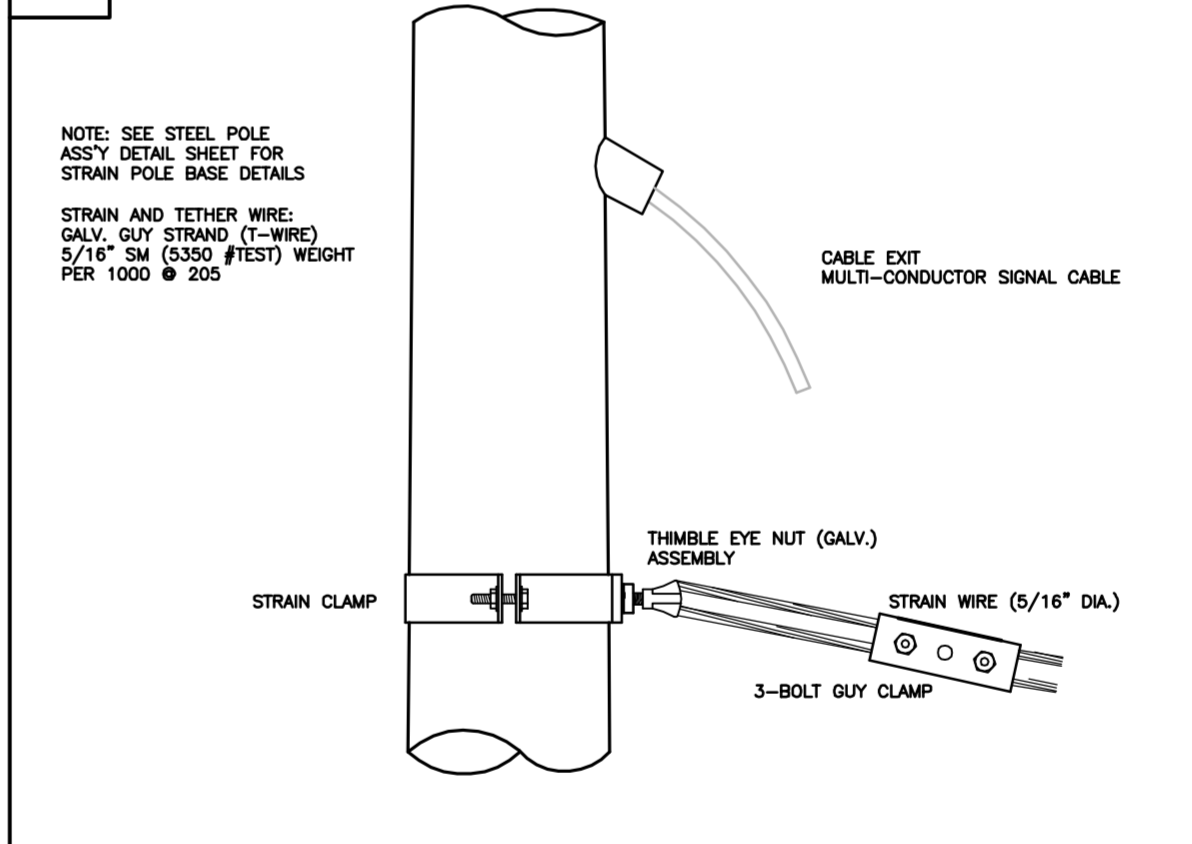

B SIGNAL BRACKET ASSEMBLY DETAILS

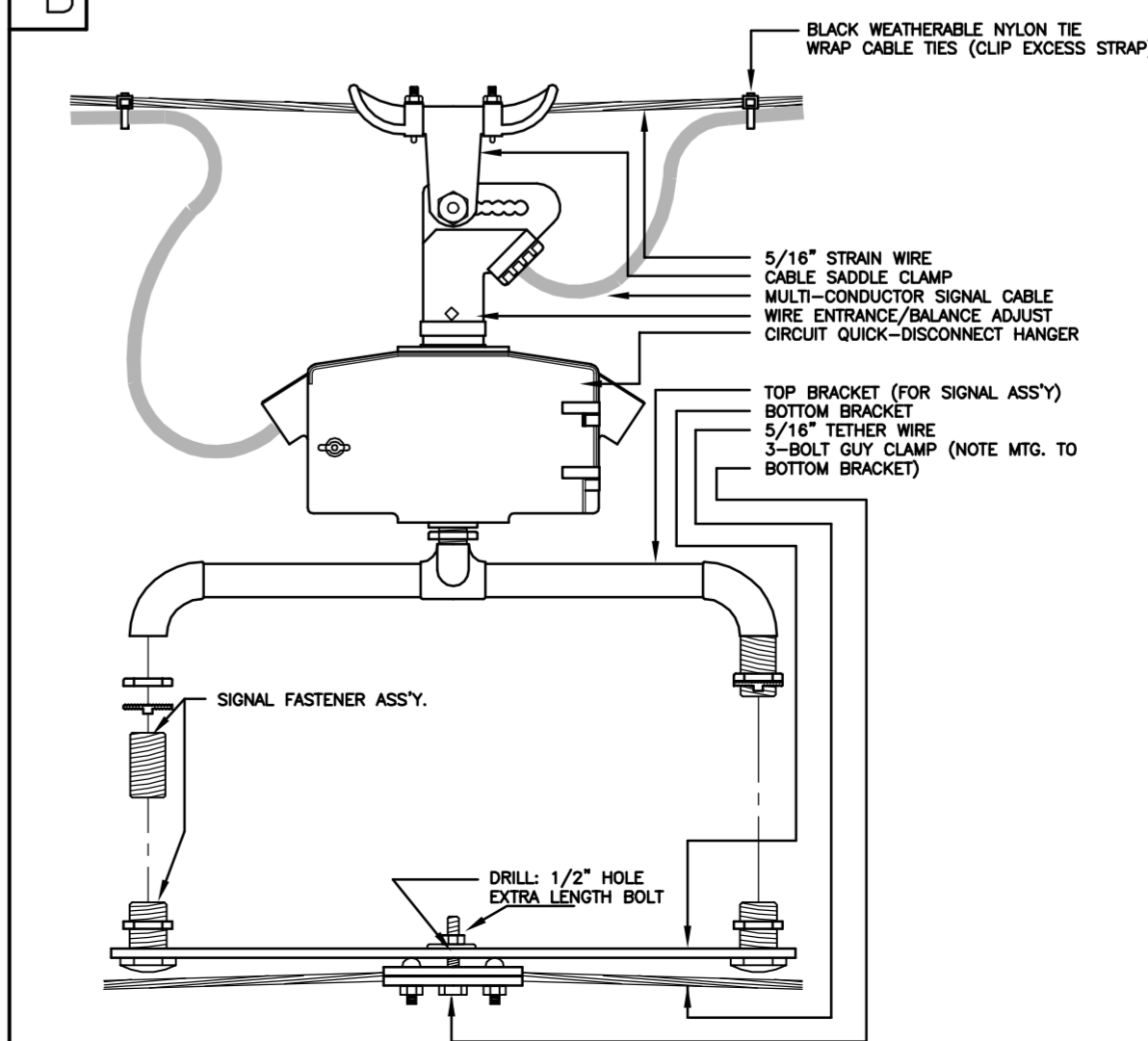

C WOOD POLE ASSEMBLY DETAILS KGE POLE EXCLUDED

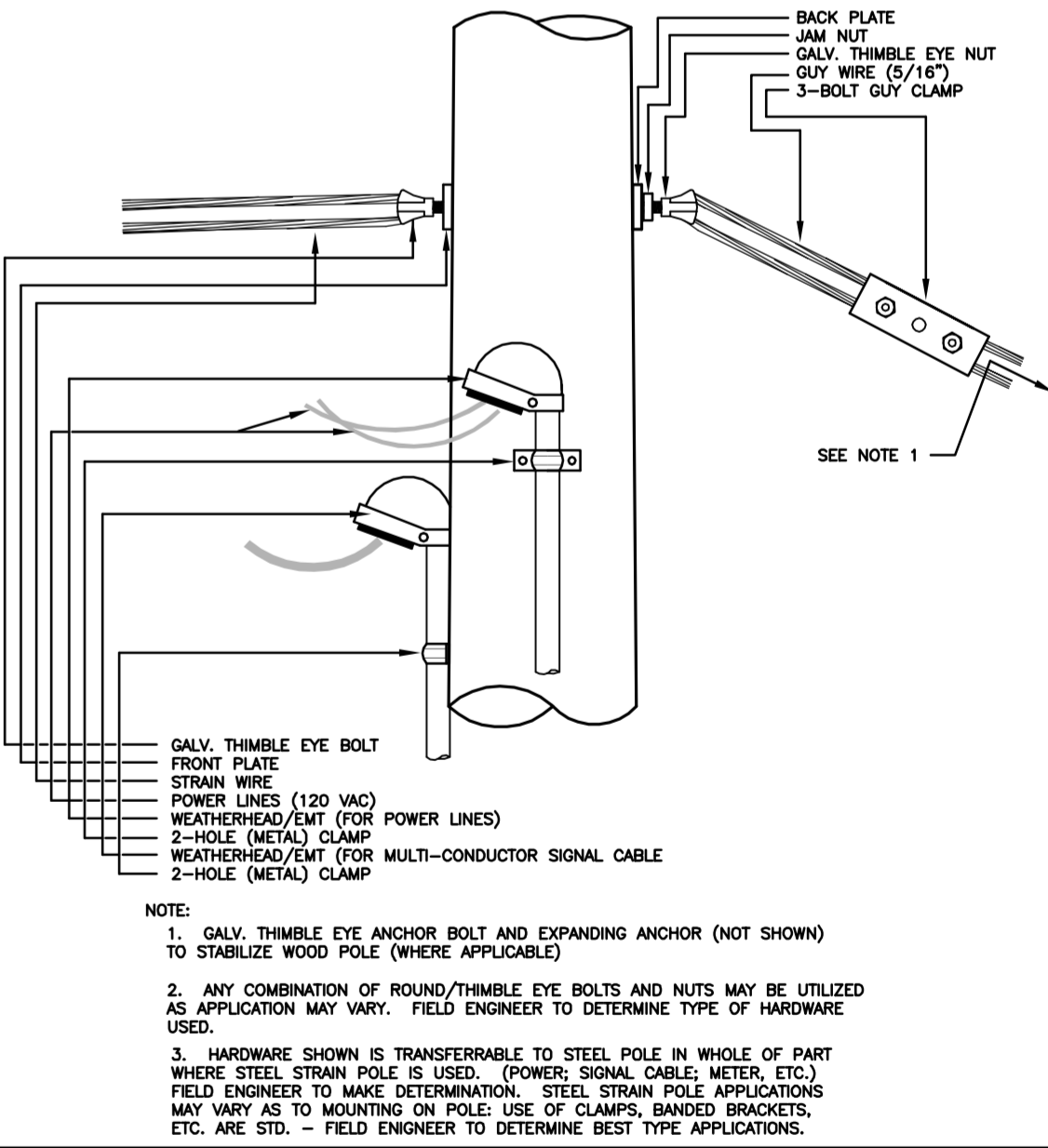

TYLER ROAD - 21ST STREET NORTH TO 29TH STREET NORTH	
POWER POLE AND SPAN POLE ASSEMBLY DETAILS	
PROJECT NUMBER 472-84921	
DRAWN BY: T.M.	APPROVED BY: L. B.
DATE: FEB. 96	DATE: 7/12/11
CITY OF WICHITA DEPARTMENT OF PUBLIC WORKS	
DIVISION OF TRAFFIC ENGINEERING	
PAUL D. GUNZELMAN, P.E. TRAFFIC ENGINEER	SHEET 62 OF 100