

- ### GRADING NOTES
- Contractor shall be required to provide notice to Kansas One Call at 887-2470 a minimum of two (2) working days prior to any excavation or work adjacent to utilities.
 - The Contractor must notify the following in case of an emergency:
 - Black Hills Energy (Gas).....1-800-303-0357
 - Westar Energy (Electric).....303-9850
 - Cox Communications (Cablevision).....262-4270
 - AT&T (Phone).....268-2759
 - City of Wichita Water Dept. (Water).....268-4563
 - City of Wichita Sewer Maint. (San. Sewer).....268-4908
 - City of Wichita Storm Sewer Maint. (Storm Sewer).....268-6000
 - City of Wich Traffic Maint. (Trsf. Control).....268-4034 or 268-4203
 - Existing utilities and their locations, as shown on the plans, represent the best information obtainable for design. Location information has been obtained from the various utility companies and is either from company record drawings or company provided field locations. The Contractor will be required to work around existing utilities which do not conflict with proposed construction.
 - Traffic affected by the construction on this project shall be handled in accordance with the latest edition of the Local Manual on Uniform Traffic Control Devices.
 - The Contractor shall verify all utility locations prior to construction of this project.
 - Refer to Landscape Plans or Specifications for Treatment of All Disturbed Areas.
 - Signaling and striping shall be installed Per Approved Specifications.
 - Paved Lot to be constructed Per Approved Specifications.
 - The Contractor shall notify adjacent landowners prior to proceeding with any construction work on landowner's property.
 - Cross-Slopes on sidewalks around building shall not exceed 1/4\"/>

Subject to Change upon completion of Soils Report

6\"/>

6\"/>

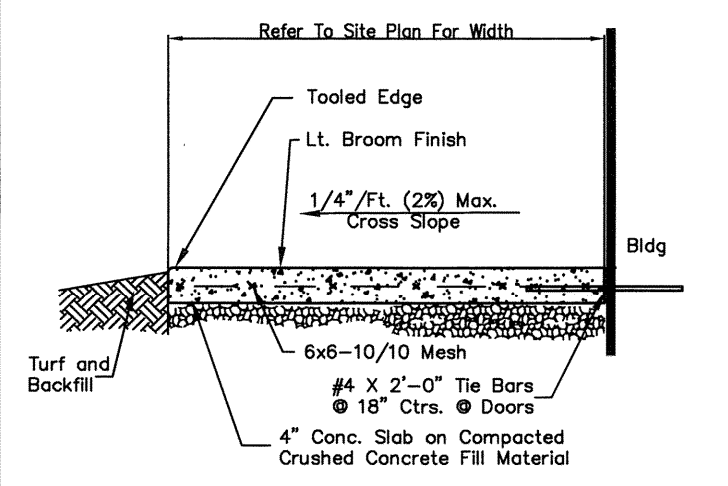

See Sheet C4 for Concrete Pavement Joint Details and notes.

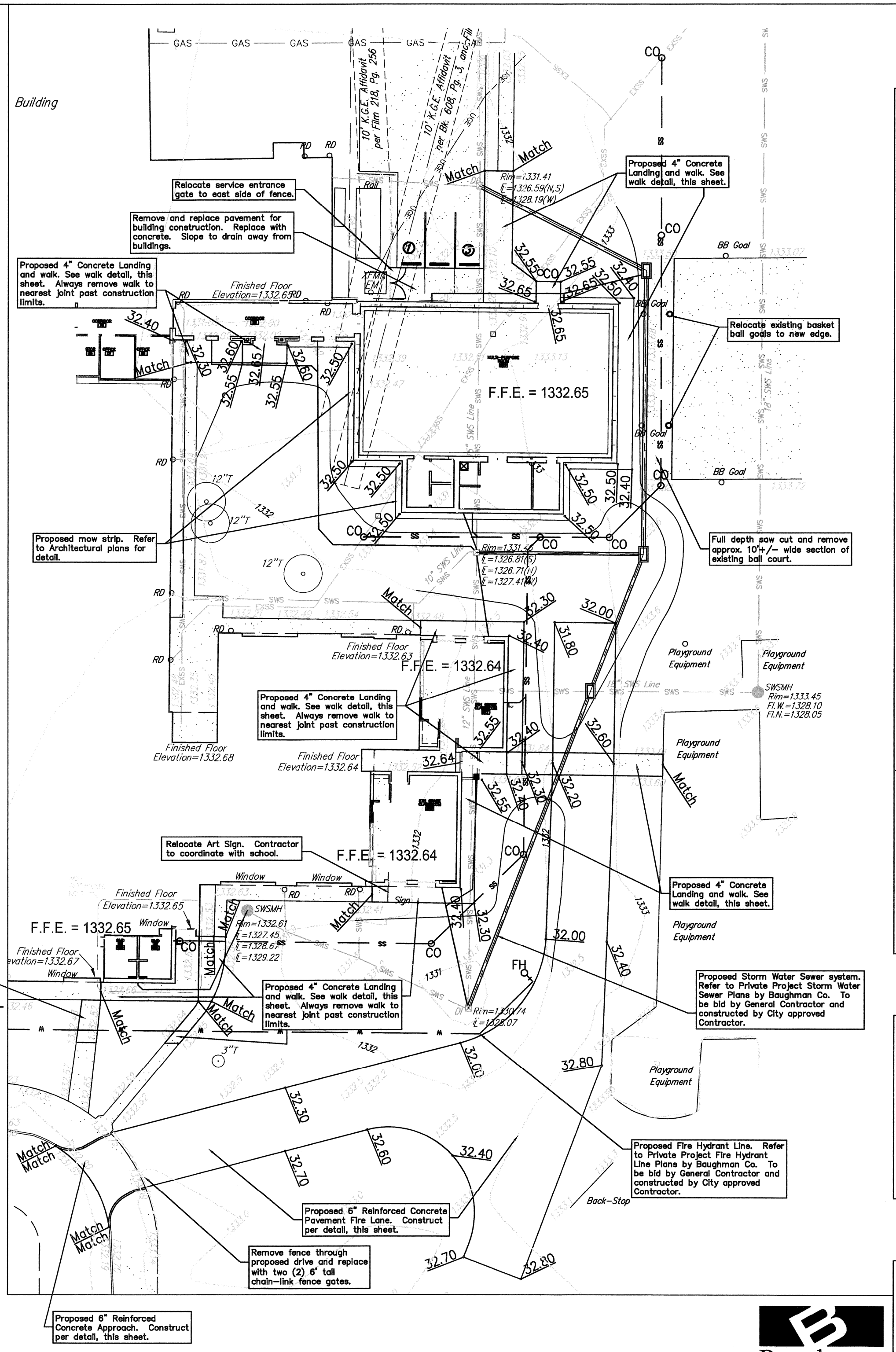
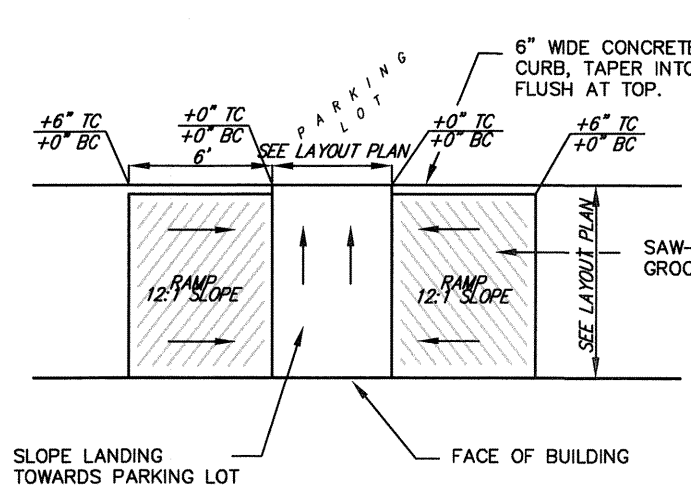

SITE GRADING PLAN

Scale 1\"/>

ADDITIONS TO:
BENTON ELEMENTARY SCHOOL
 338 S. WOODCHUCK LANE
 WICHITA, KANSAS



SHEET C1

FILE NO. 1108
 PREPARED BY: B.A.M.
 CHECKED BY: B.A.M.
 REVISIONS:



For Reference Only
 See Civil Siteplan
 R1 OF R3
 Not To Scale

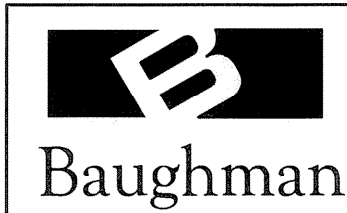

Baughman Company, P.A. 315 Ellis St. Wichita, KS 67211 P 316-262-7271 F 316-262-0149
 ENGINEERING | SURVEYING | PLANNING | LANDSCAPE ARCHITECTURE