

APPROVED	DESIGNED	DETAILED
DESIGN CK.	DESIGN CK.	DETAIL CK.
QUANTITIES	QUANTITIES	TRACED
QUANCK.	QUANCK.	TRACE CK.

Plotted on: Wednesday, November 26, 2008 10:32 AM
 By: amestdagh
 Design File Name: \\ovpw00\Jobs\43244\CD\Detail\restrained joint detail.dgn

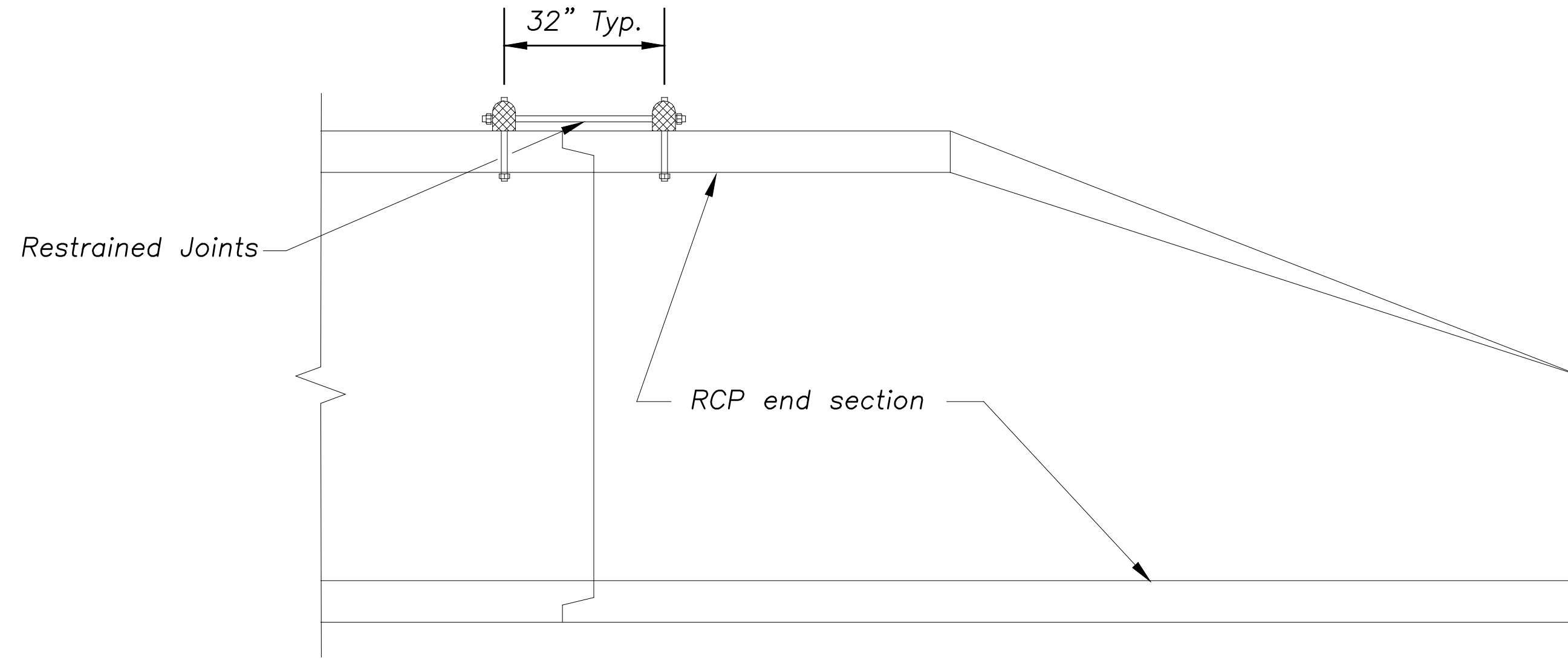

Notes:

The restrained joint hardware shall be hot dip zinc coated in accordance with ASTM A-123.

Joints must be approved by the City prior to installation.

Restrained joints will be subsidiary to RCP End Sections.

SHEET NO.	TOTAL SHEETS
-----------	--------------

7450 W 130th St., Suite 400
 Overland Park, KS 66213
 (913) 491-9833

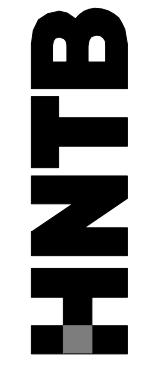

CITY OF
 WICHITA, KANSAS



NO.	DATE	BY	APPTD	REVISIONS
4				
3				
2				
1				

RESTRAINED JOINT DETAILS