

DEETER #2433 GRATE

24" x 24" Frame and Grate Detail

NOTE: Grates shall be imprinted on the top surface with "CITY OF WICHITA" using letters at least 1" in height. Other marking methods may be approved by the engineer.

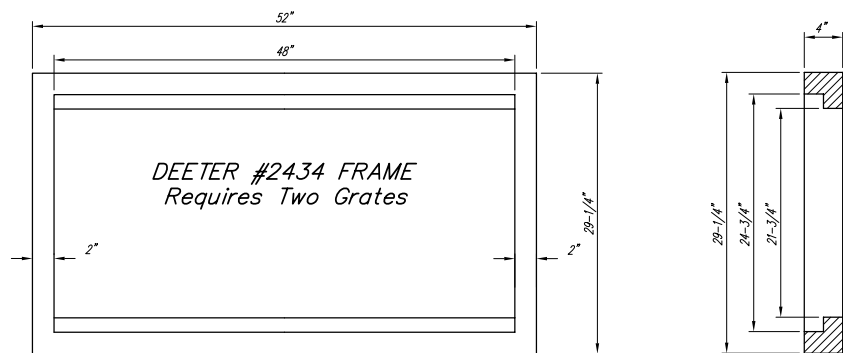

Double 24" x 24" Frame Detail

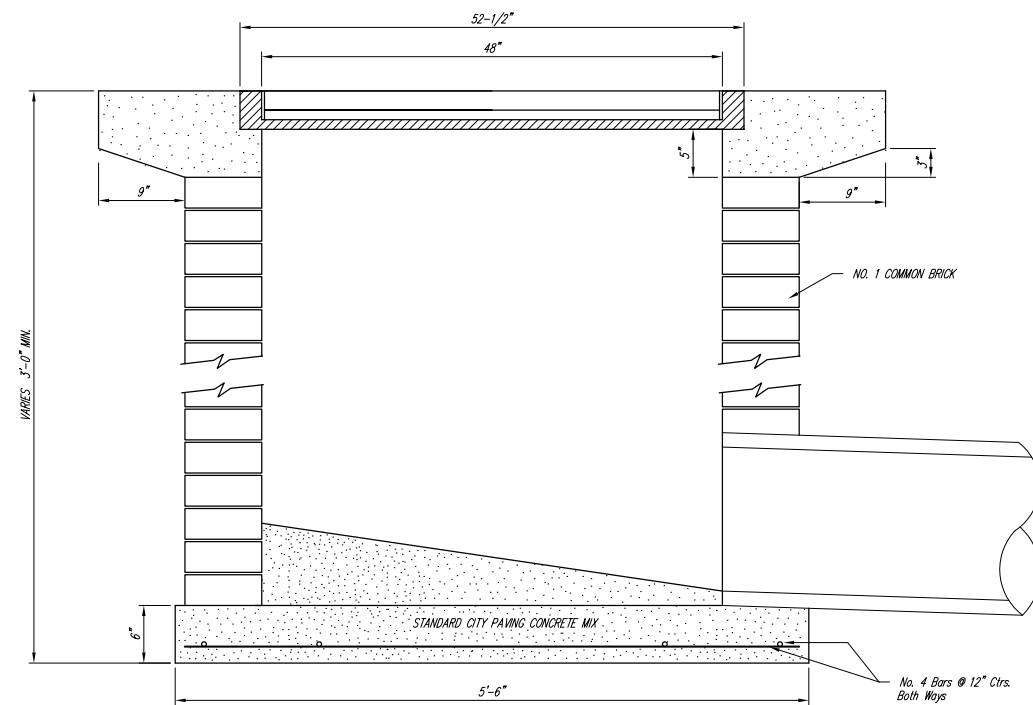
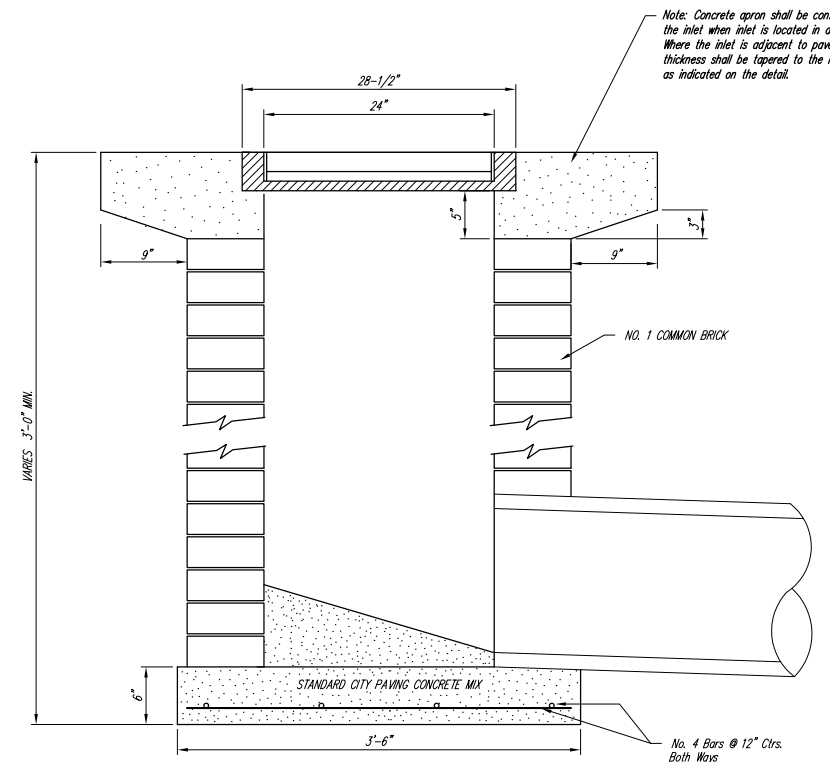
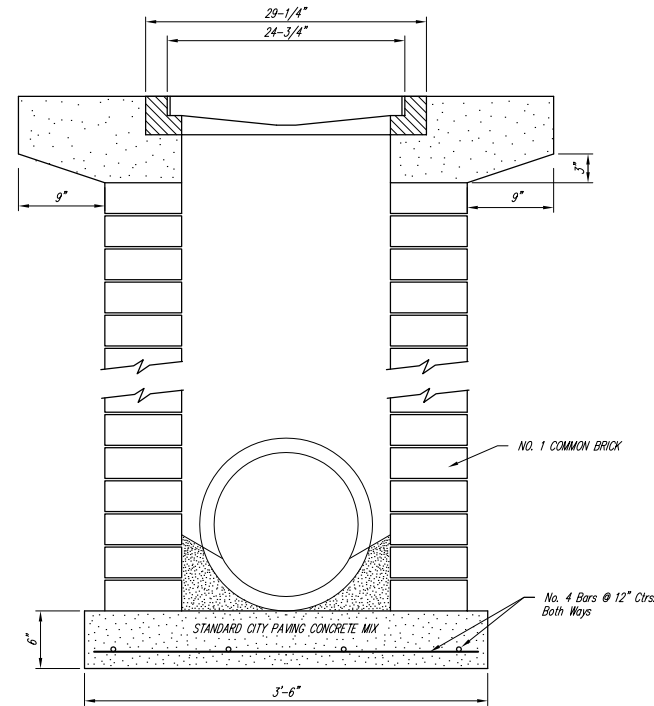

	City of Wichita Standard	
	Drop Inlet Detail	
<small>Baughman Company, P.A. 315 Ellis St. Wichita, KS 67211 F3162627271 F3163620149 ENGINEERING SURVEYING PLANNING LANDSCAPE ARCHITECTURE</small>		
PROJECT NUMBER	DESIGN	DRAWN
	C.O.W.	Staff
REVISIONS:	APPROVED	DATE
	SCALE	
	None	
	SHEET	
		18 OF 32
<small>F:\Erg\Details\sewers\DROPINT2.swg</small>		