

12 WHEELCHAIR RAMP IN SIDEWALK
N.T.S.

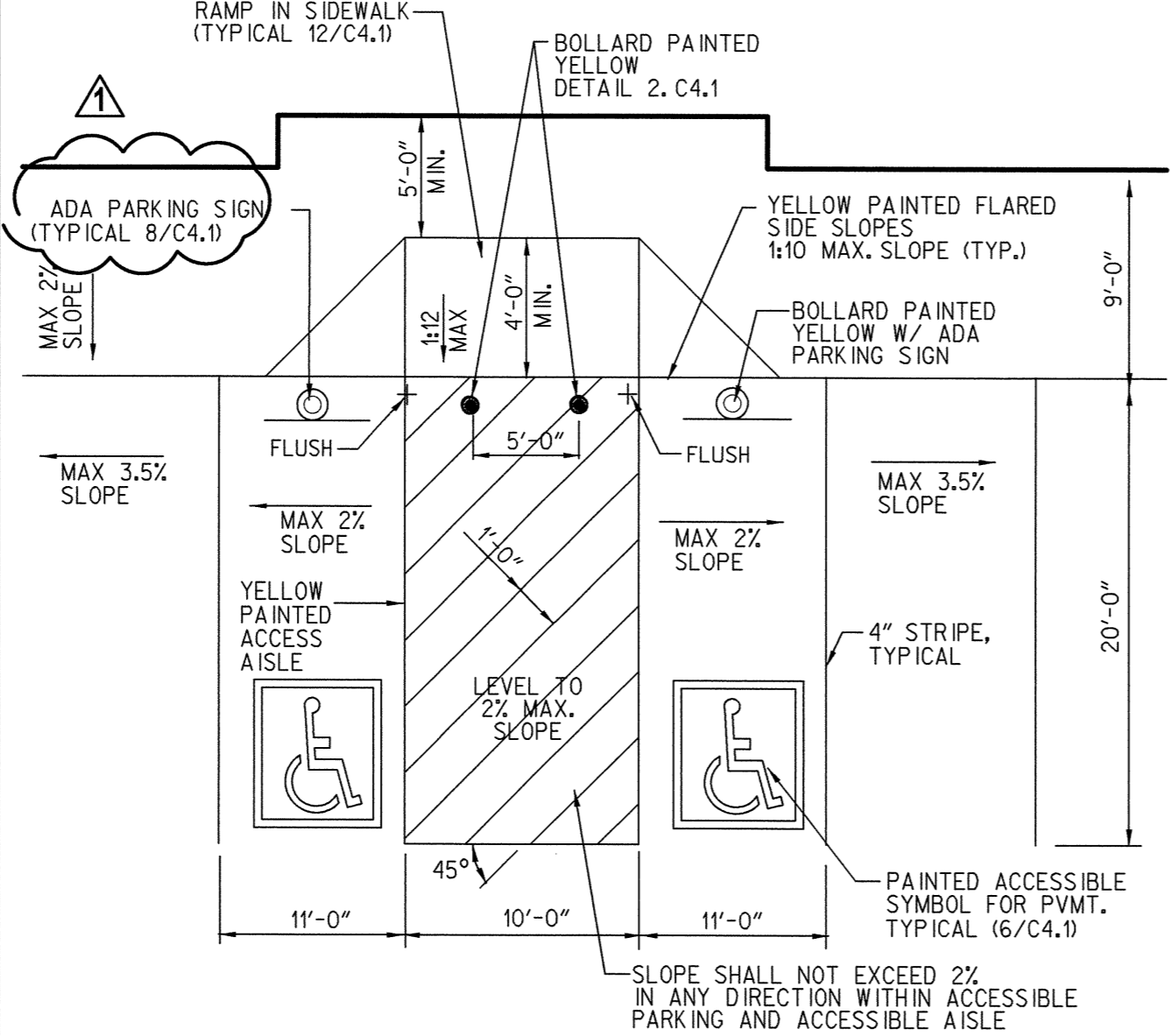

9 ACCESSIBLE PARKING LAYOUT
N.T.S.

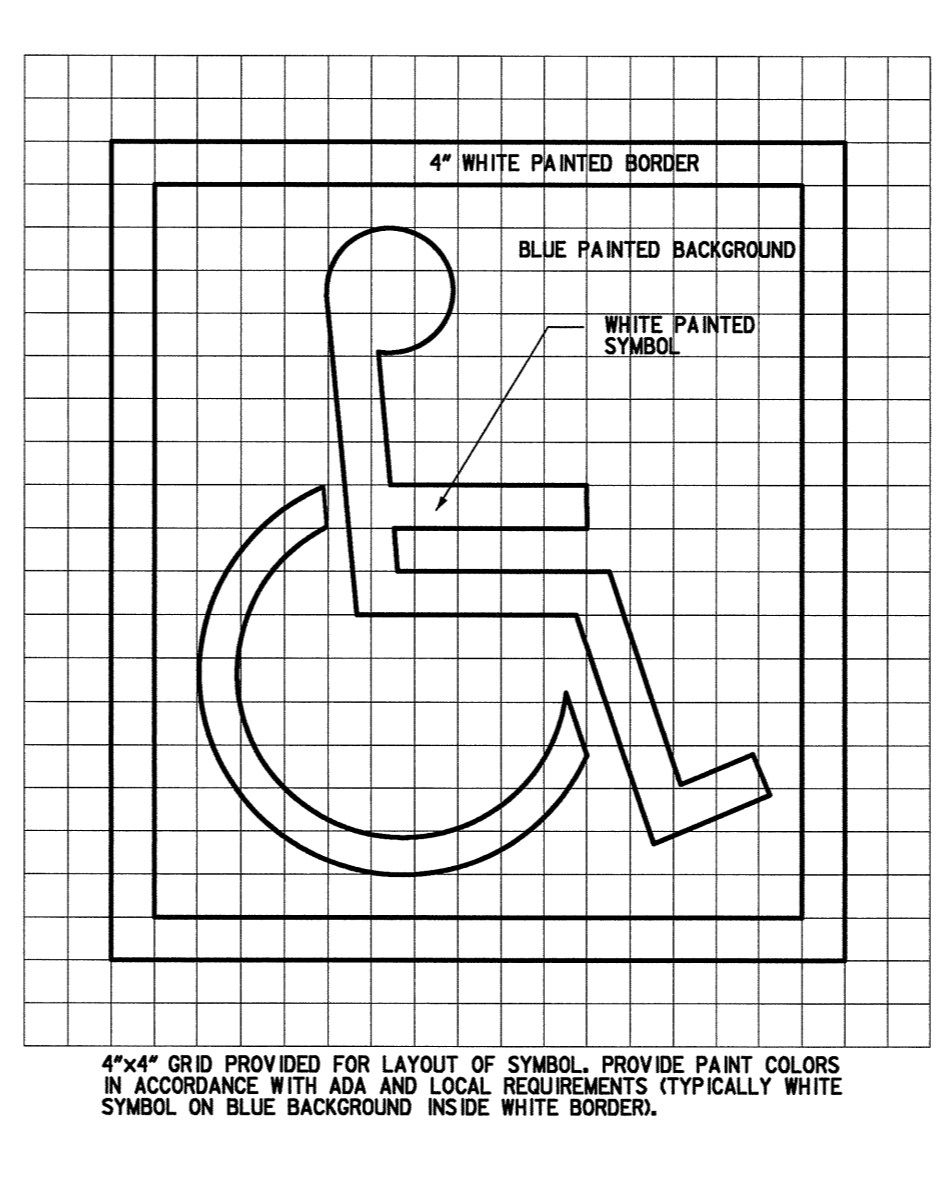

6 ACCESSIBLE SYMBOL
N.T.S.

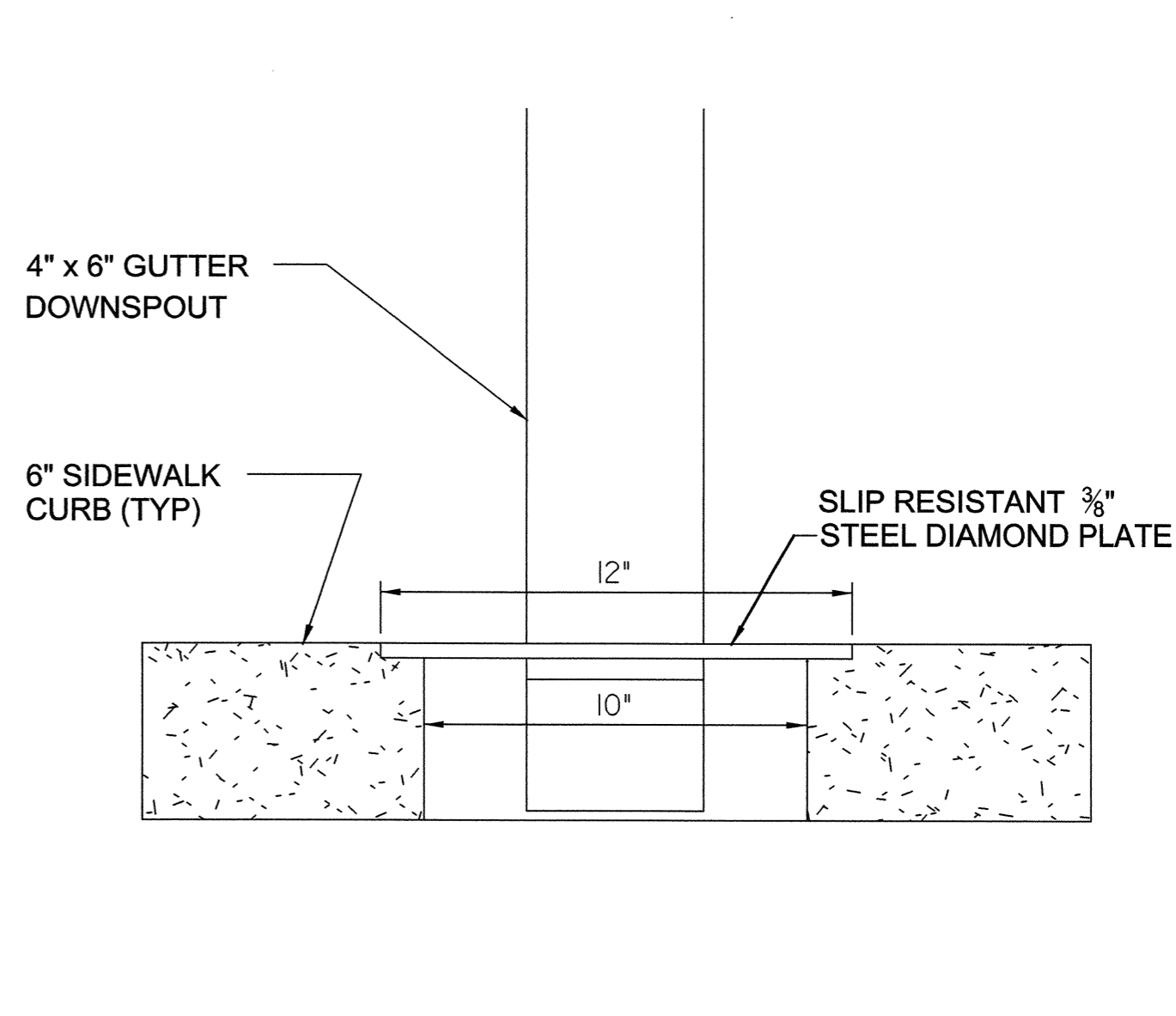

3 GUTTER DOWNSPOUT AT SIDEWALK
N.T.S.

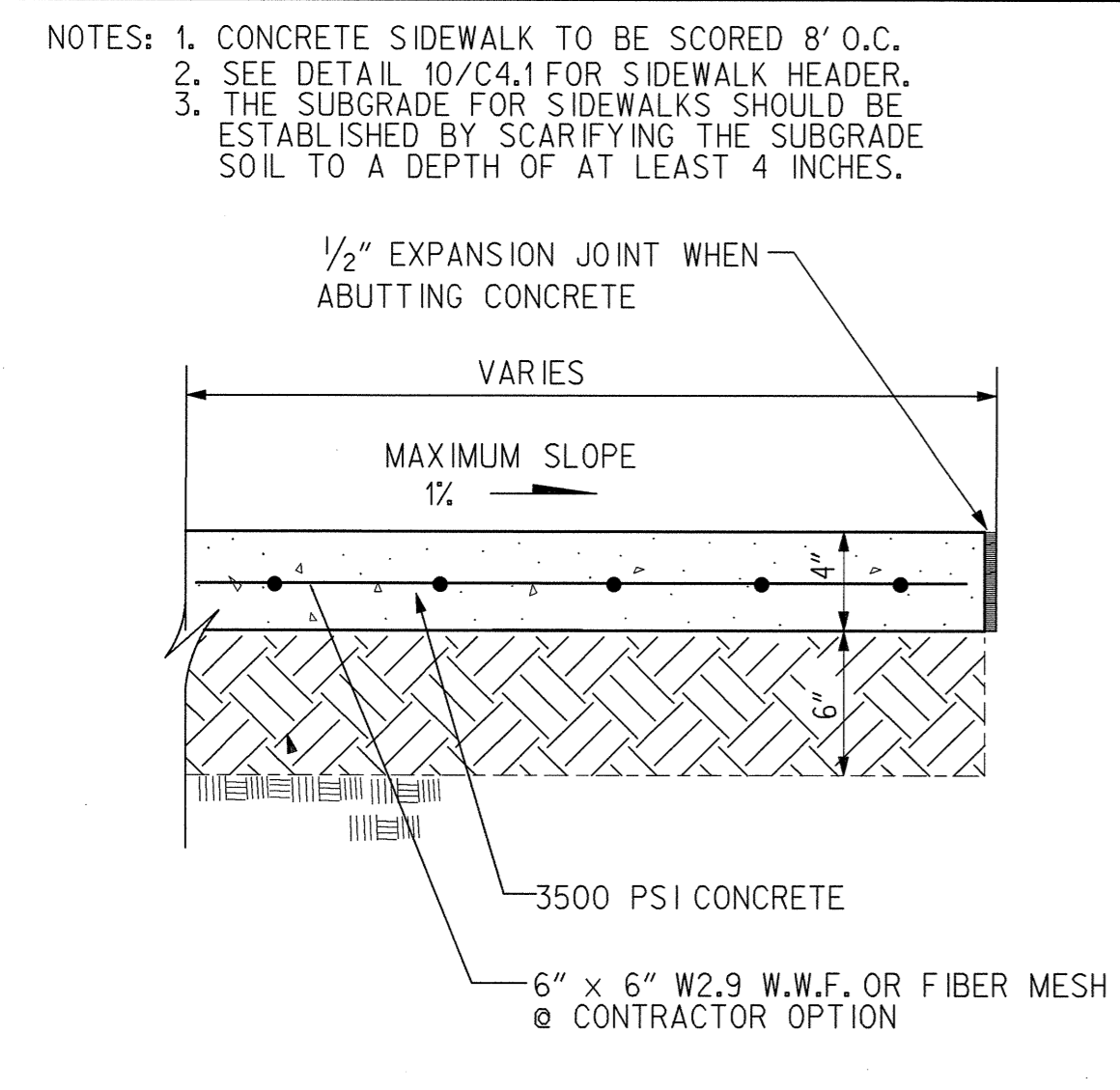

11 CONCRETE SIDEWALK SECTION
N.T.S.

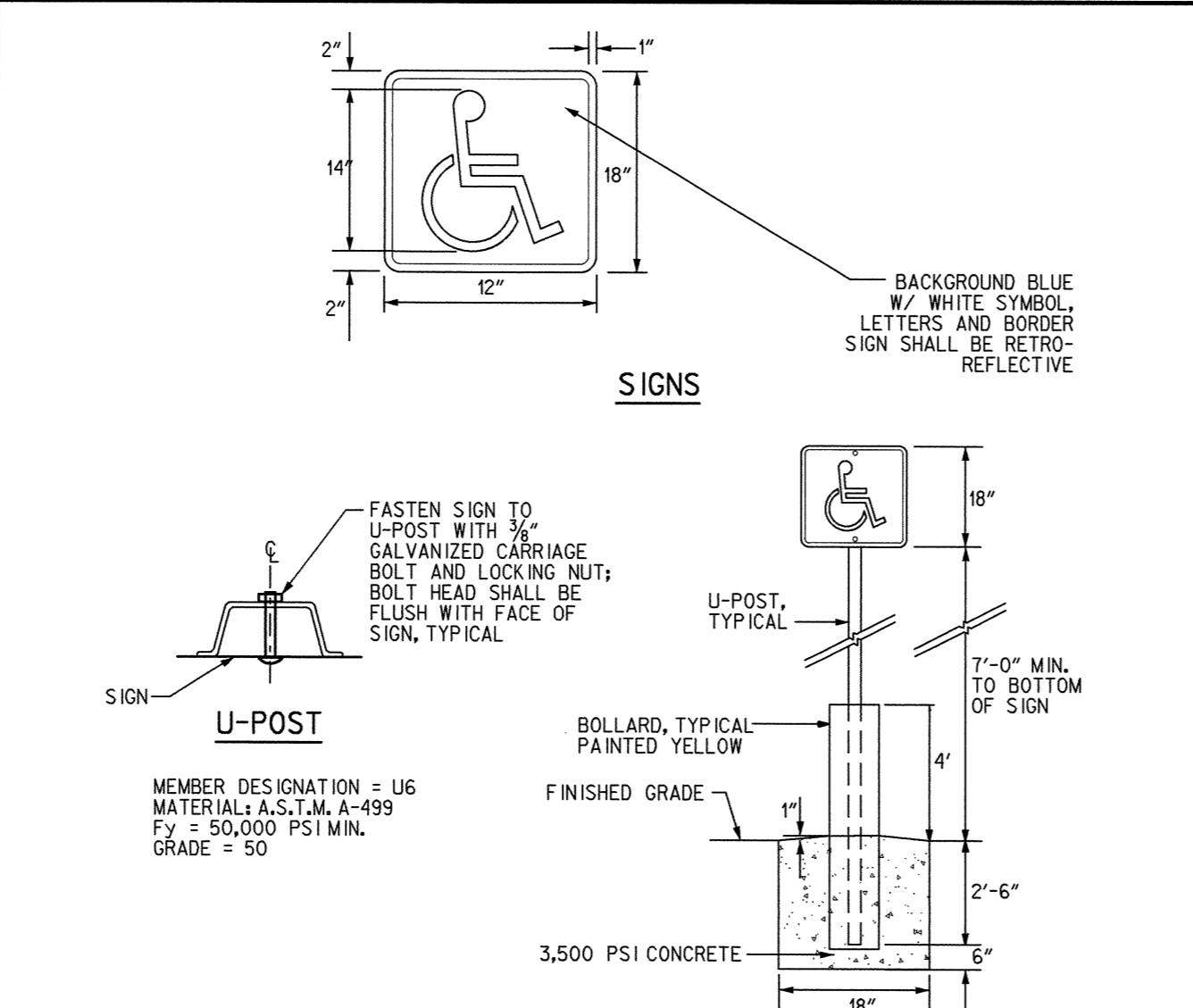

8 ACCESSIBLE SIGNAGE
N.T.S.

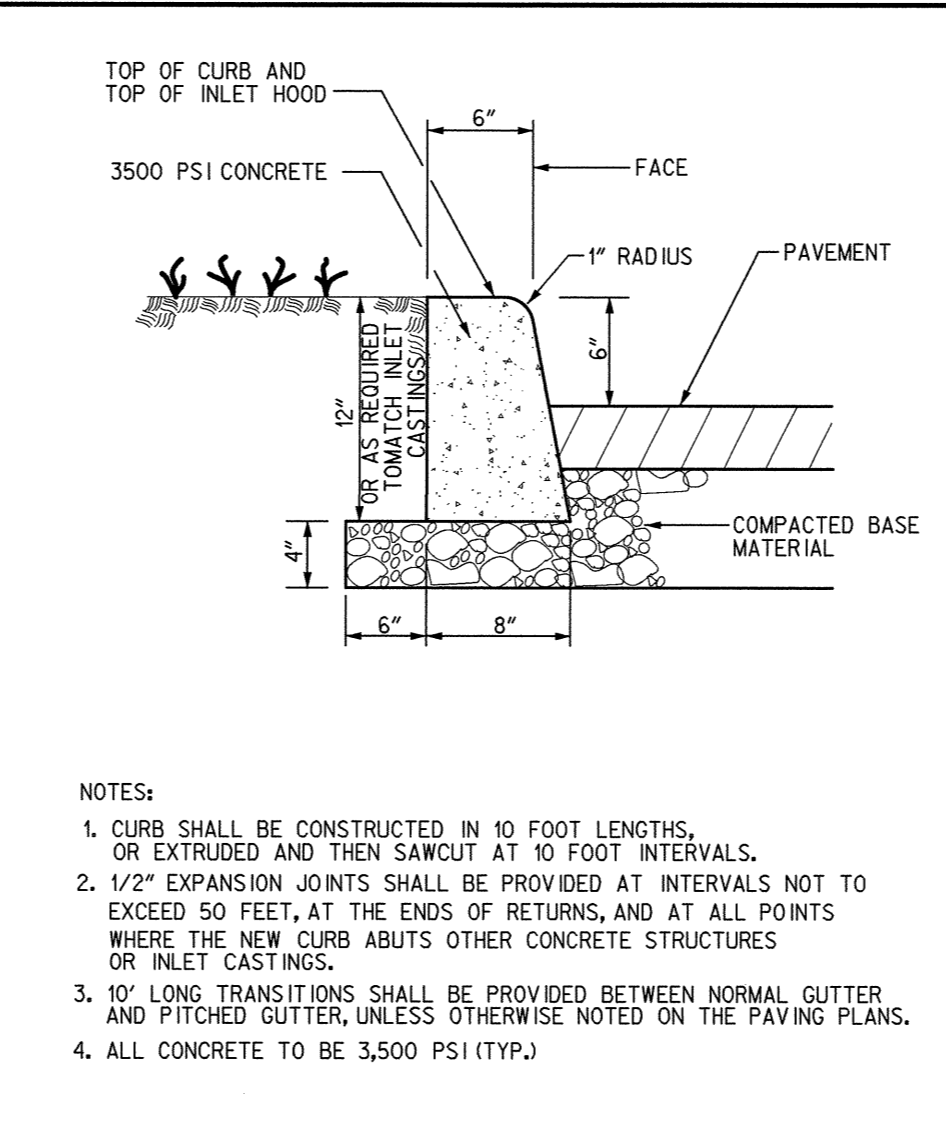

5 POST CURB
N.T.S.

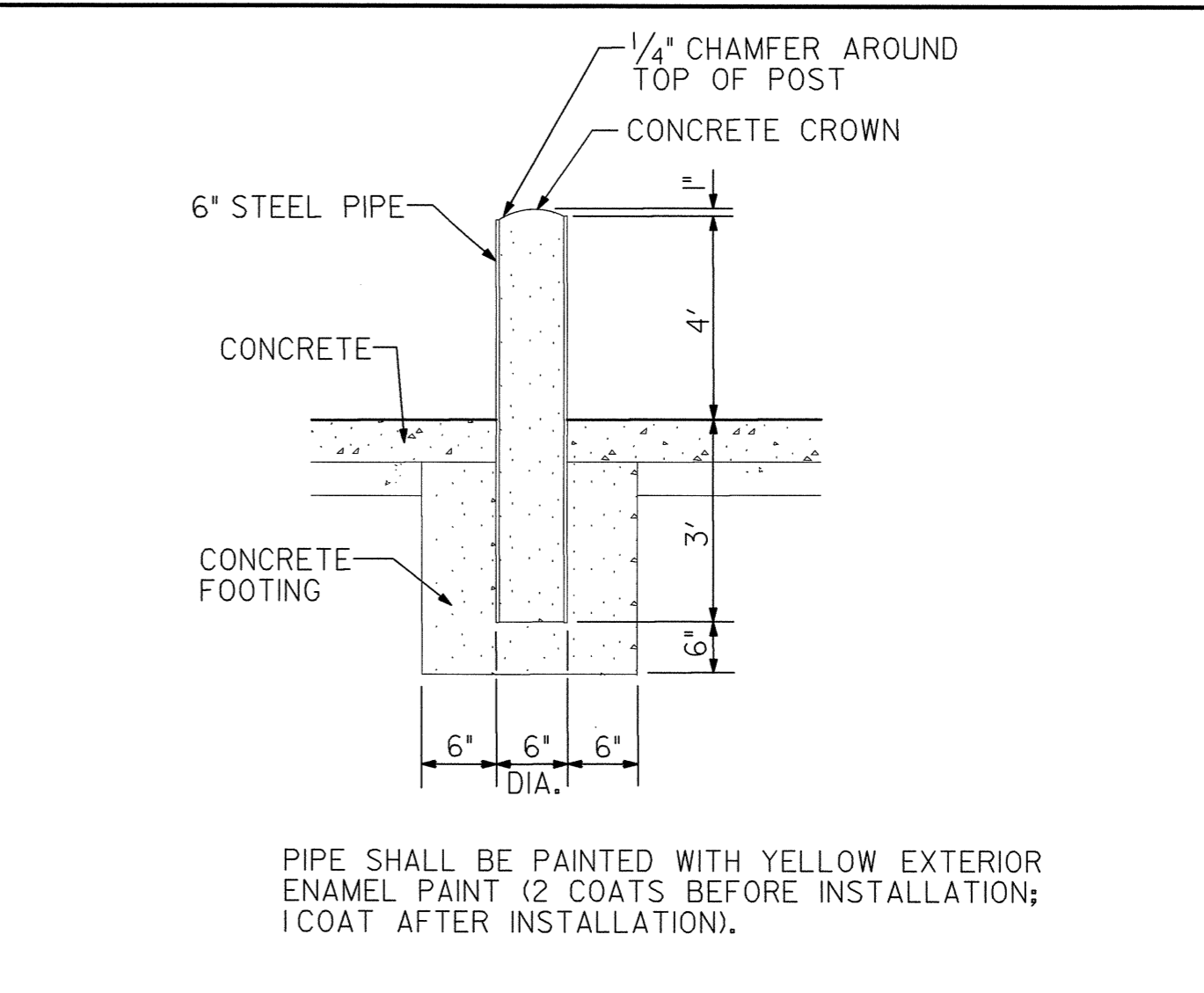

2 BOLLARD
N.T.S.

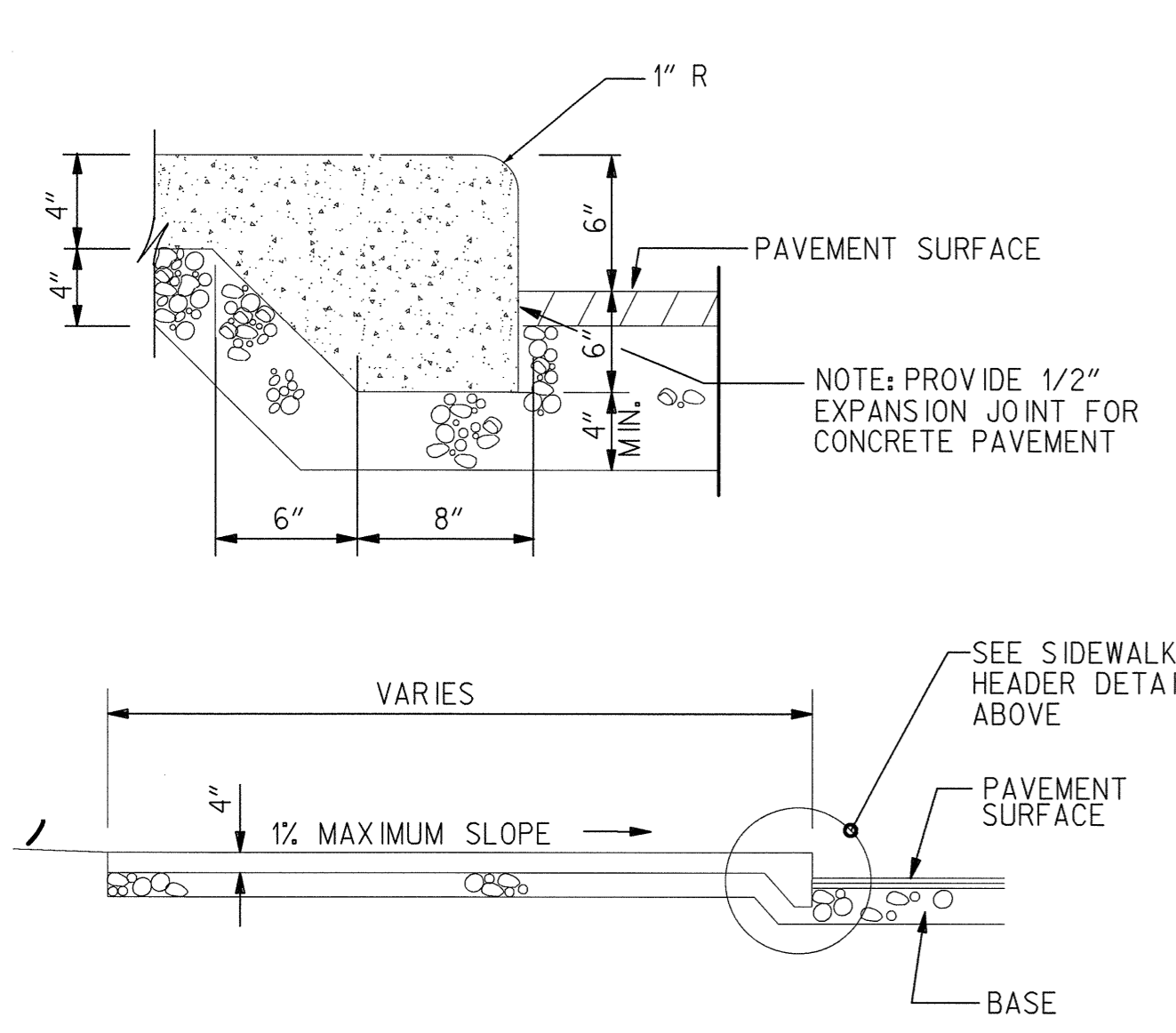

10 CONCRETE SIDEWALK HEADER
N.T.S.

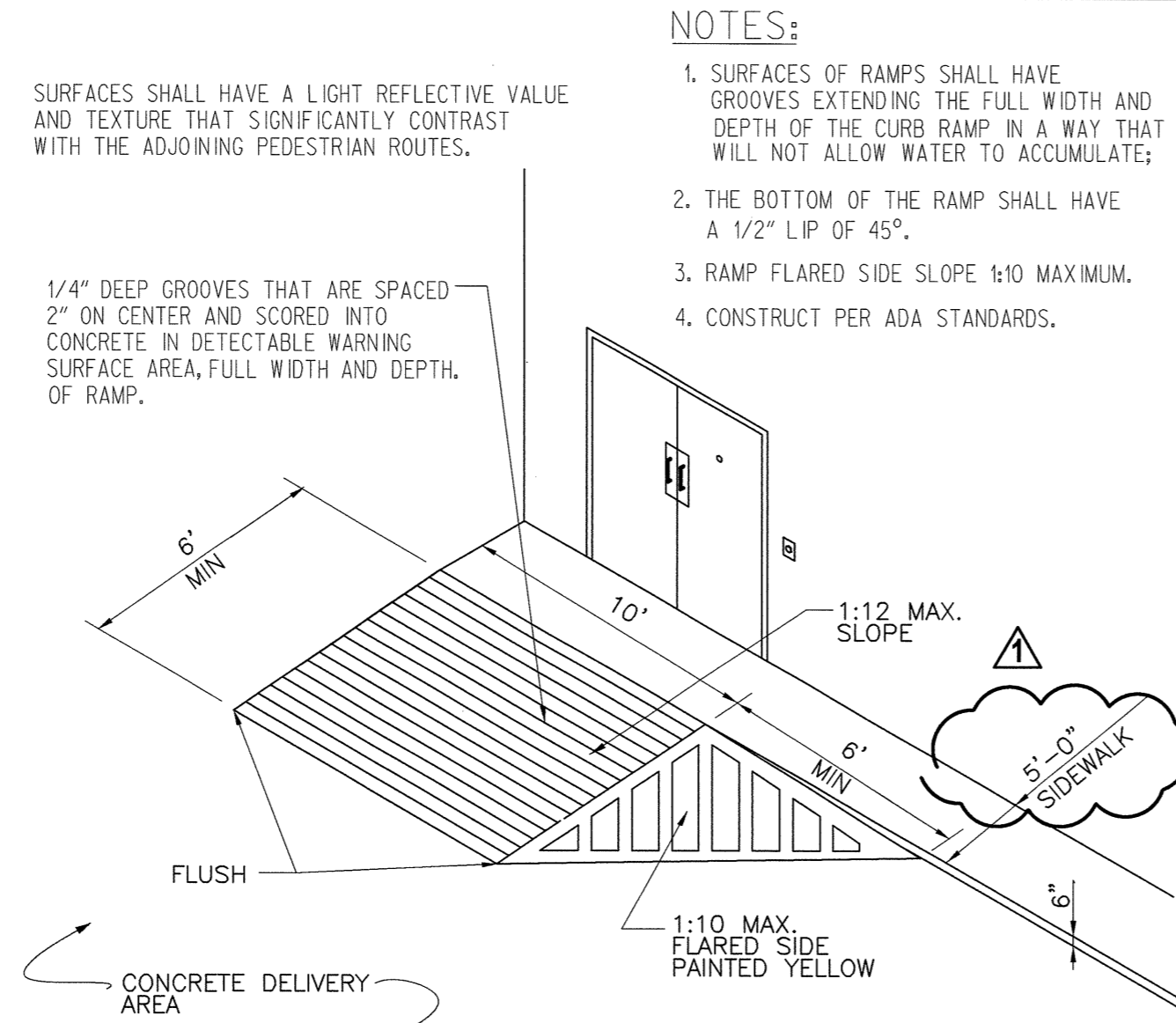

7 RAMP AT STOCK ROOM DOOR
N.T.S.

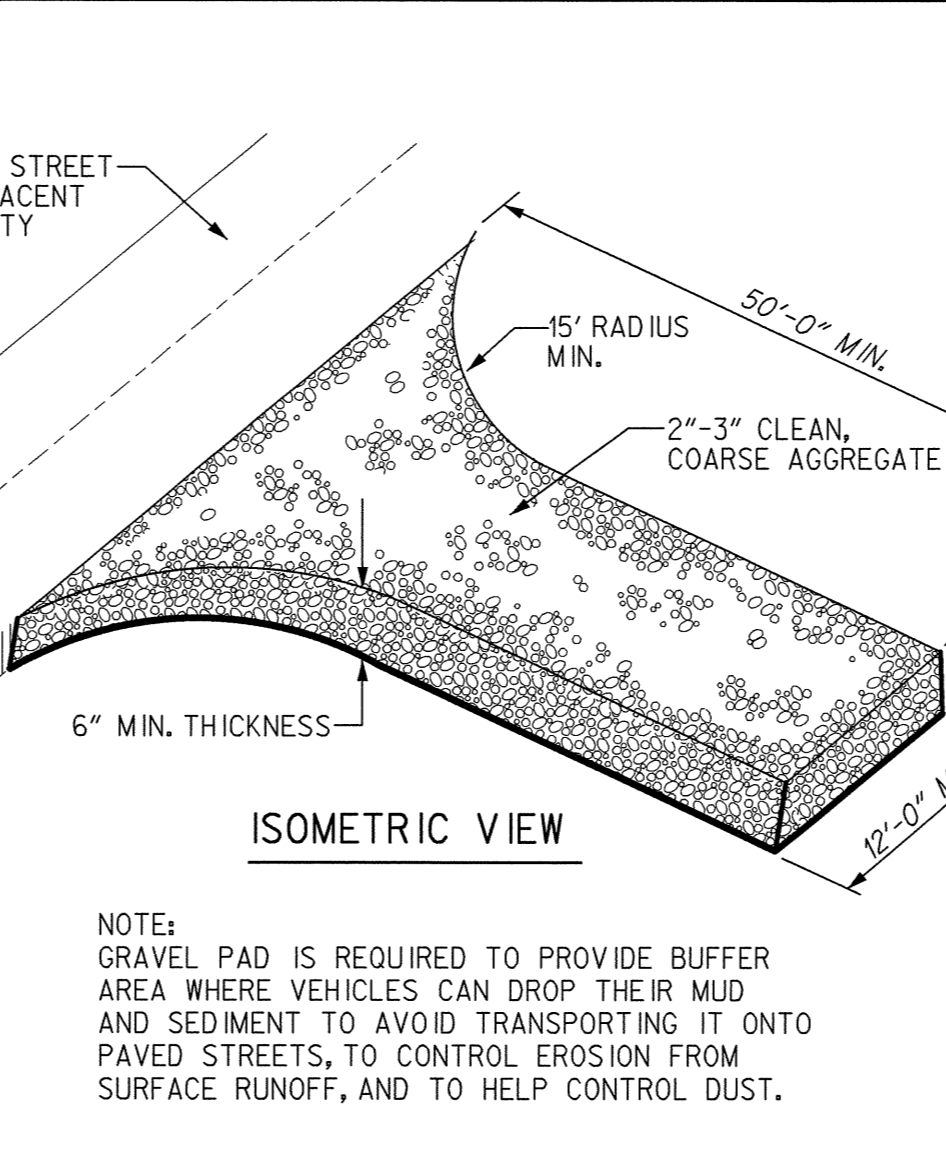

4 TEMPORARY CONSTRUCTION ENTRANCE/EXIT
N.T.S.

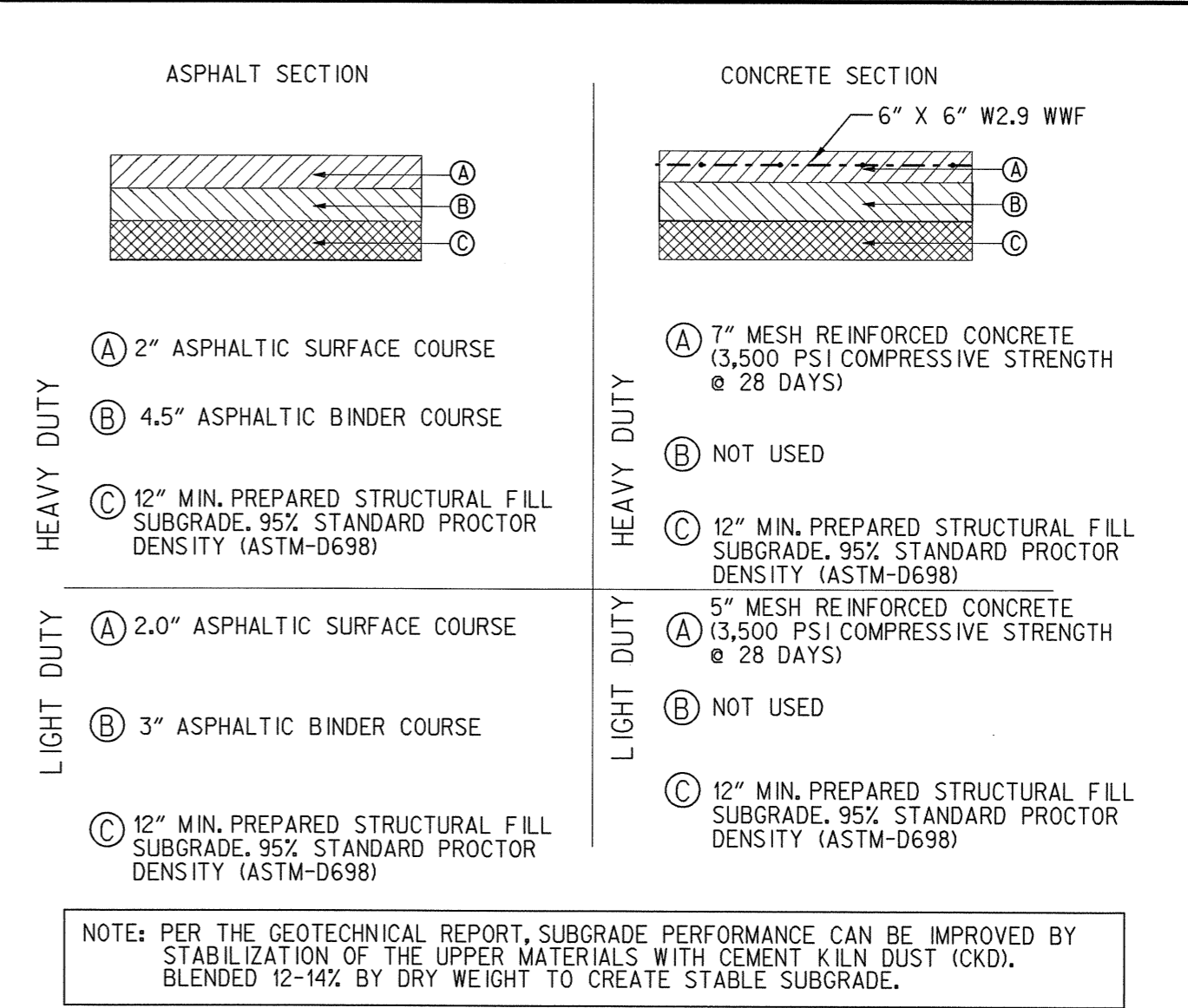

1 PAVEMENT SECTIONS
N.T.S.



ARCHITECTURE
PLANNING
ENGINEERING
GRAPHICS

105 BROADWAY
4TH FLOOR
NASHVILLE, TN 37201
(p) 615.244.8170
(f) 615.244.8141
www.mjmarch.com

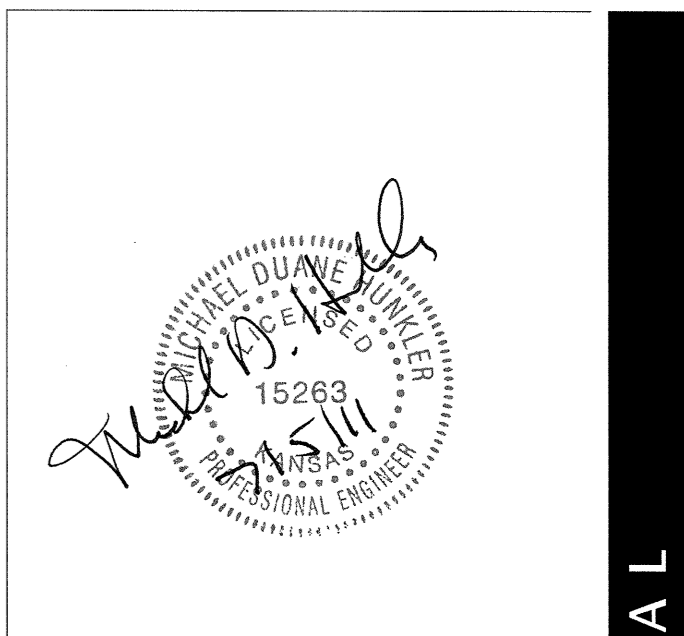

MICHAEL DUANE HUNKLER
REG.# 15263

CIVIL ENGINEER
GRESHAM SMITH AND PARTNERS

511 Union Street
1400 Nashville City Center
Nashville, Tennessee 37219
Phone: (615)770-8100
CSP #28359.00

GB

GBT REALTY CORPORATION
201 Summit Drive Suite 110
Brentwood, TN 37027
615-370-9676
Fax: 615-373-3111
www.gbrealty.com

DOLLAR GENERAL

STORE #: XXXX
**WICHITA,
KS AT
PAWNEE**

06.07.11
MJM 11074

DATE	CITY COMMENTS
07.05.11	

SITE DETAILS

C4.1

ARCHITECTS
SEAL
CONSULTANT
OWNER
LOCATION
DATE
SHEET

NOTE: PER THE GEOTECHNICAL REPORT, SUBGRADE PERFORMANCE CAN BE IMPROVED BY STABILIZATION OF THE UPPER MATERIALS WITH CEMENT K.L.N.D.U.S.T. (CKD). BLENDED 12-14% BY DRY WEIGHT TO CREATE STABLE SUBGRADE.

REFER TO GEOTECHNICAL INVESTIGATION PREPARED BY PSI
DATED: APRIL 13, 2011

This drawing and the design shown is the property of the architect. The reproduction, copying or use of this drawing without their written consent is prohibited and any infringement will be subject to legal action.