

NOT USED

12

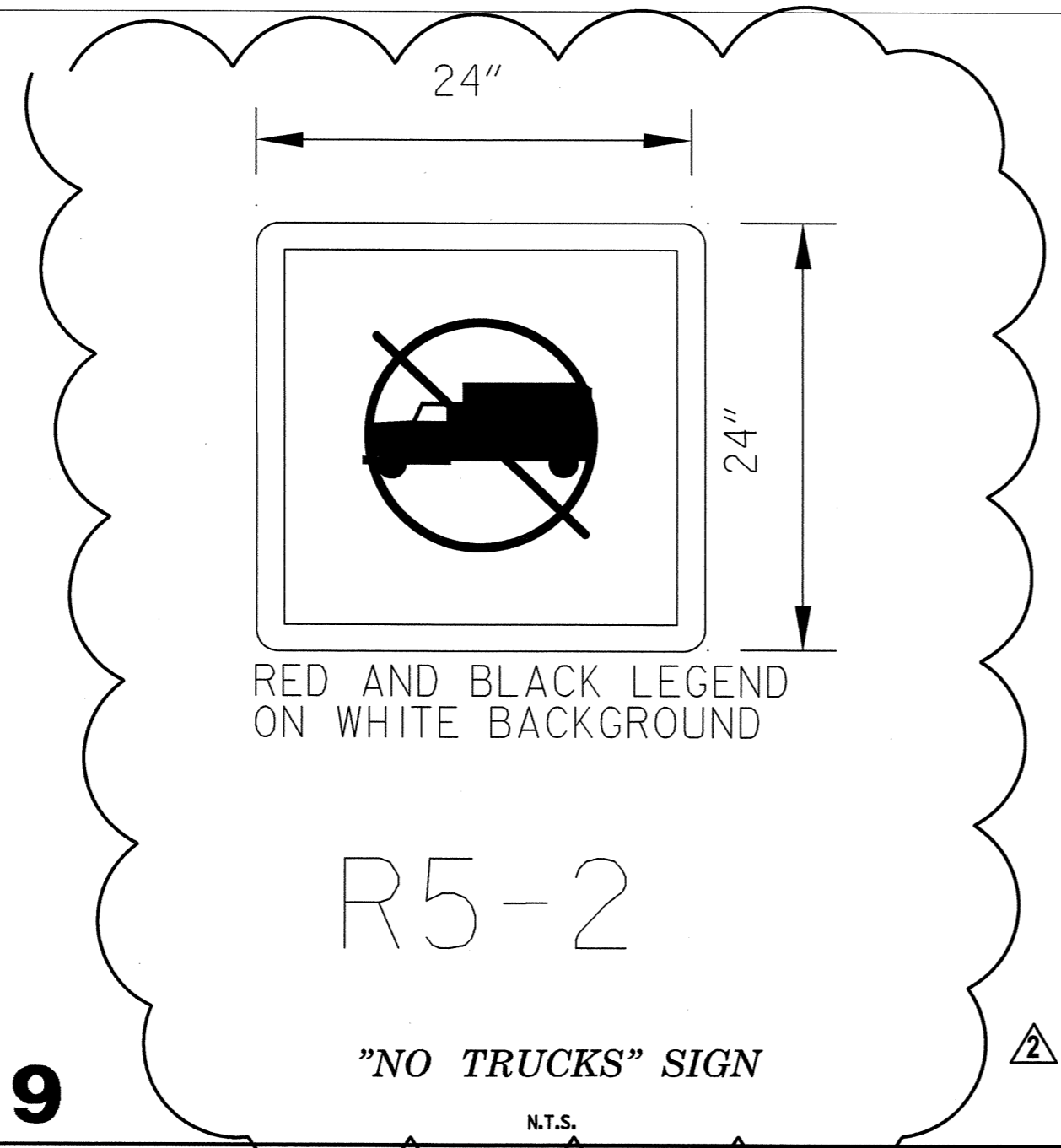

6

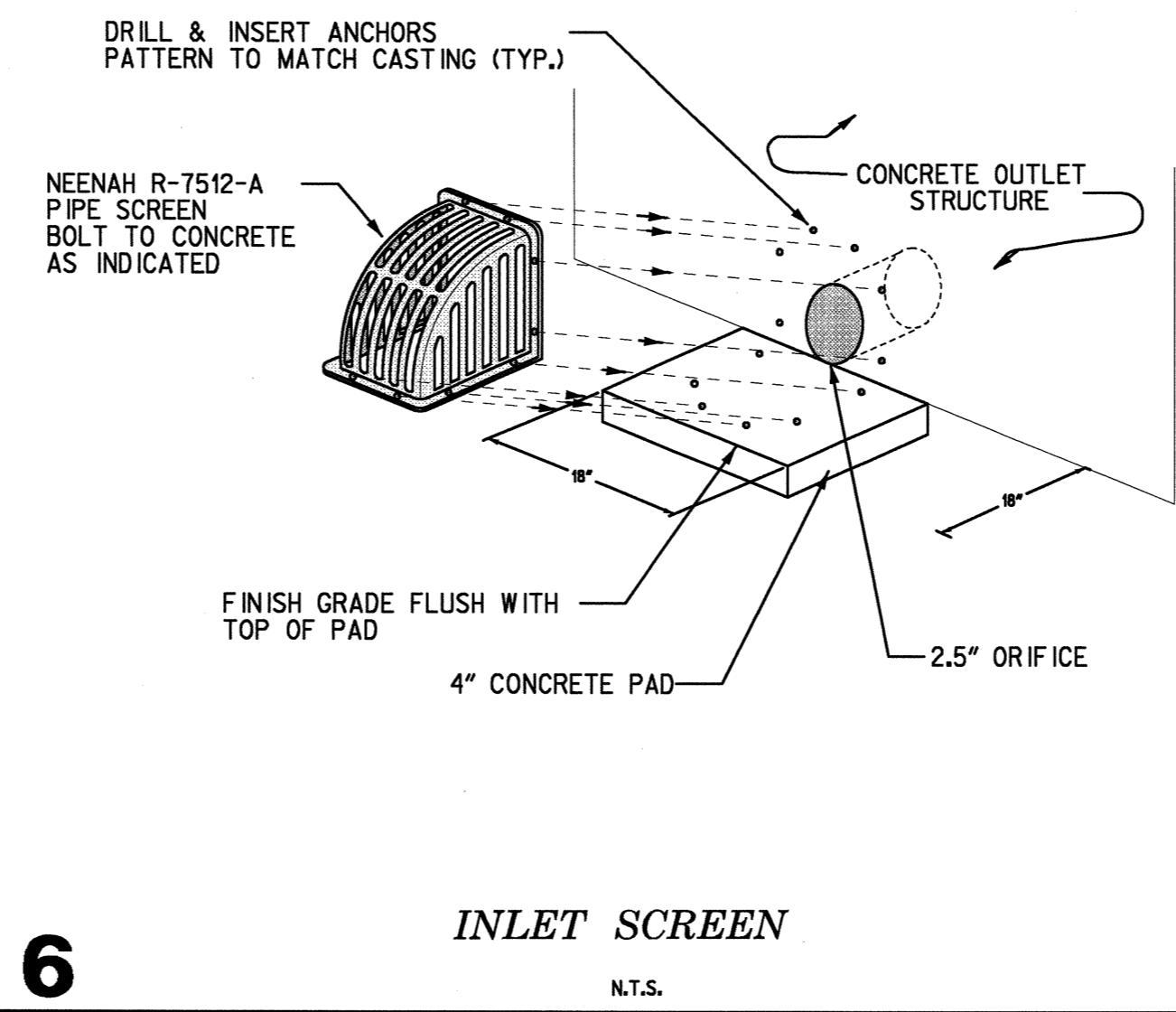

3

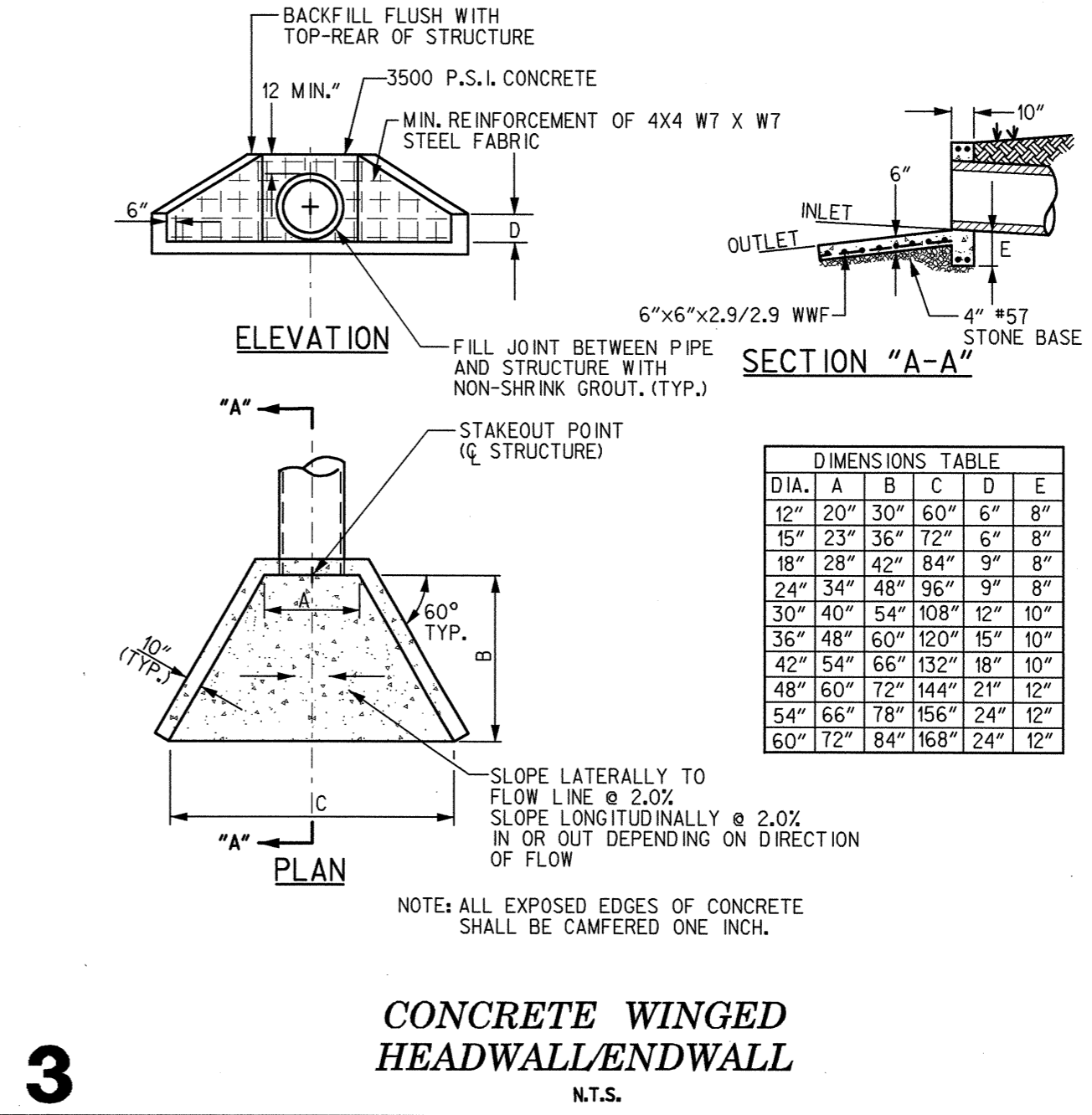

NOT USED

11

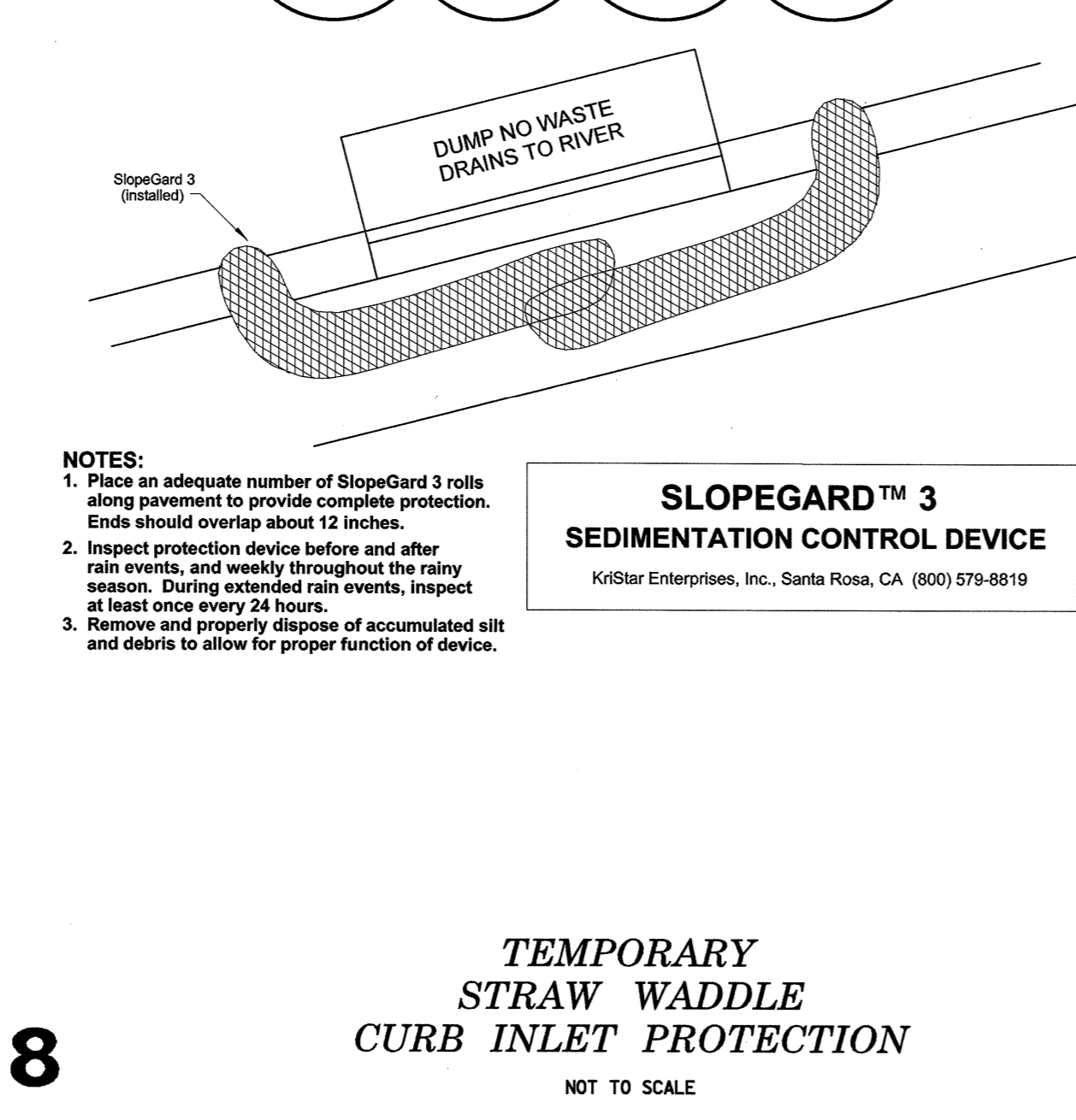

5

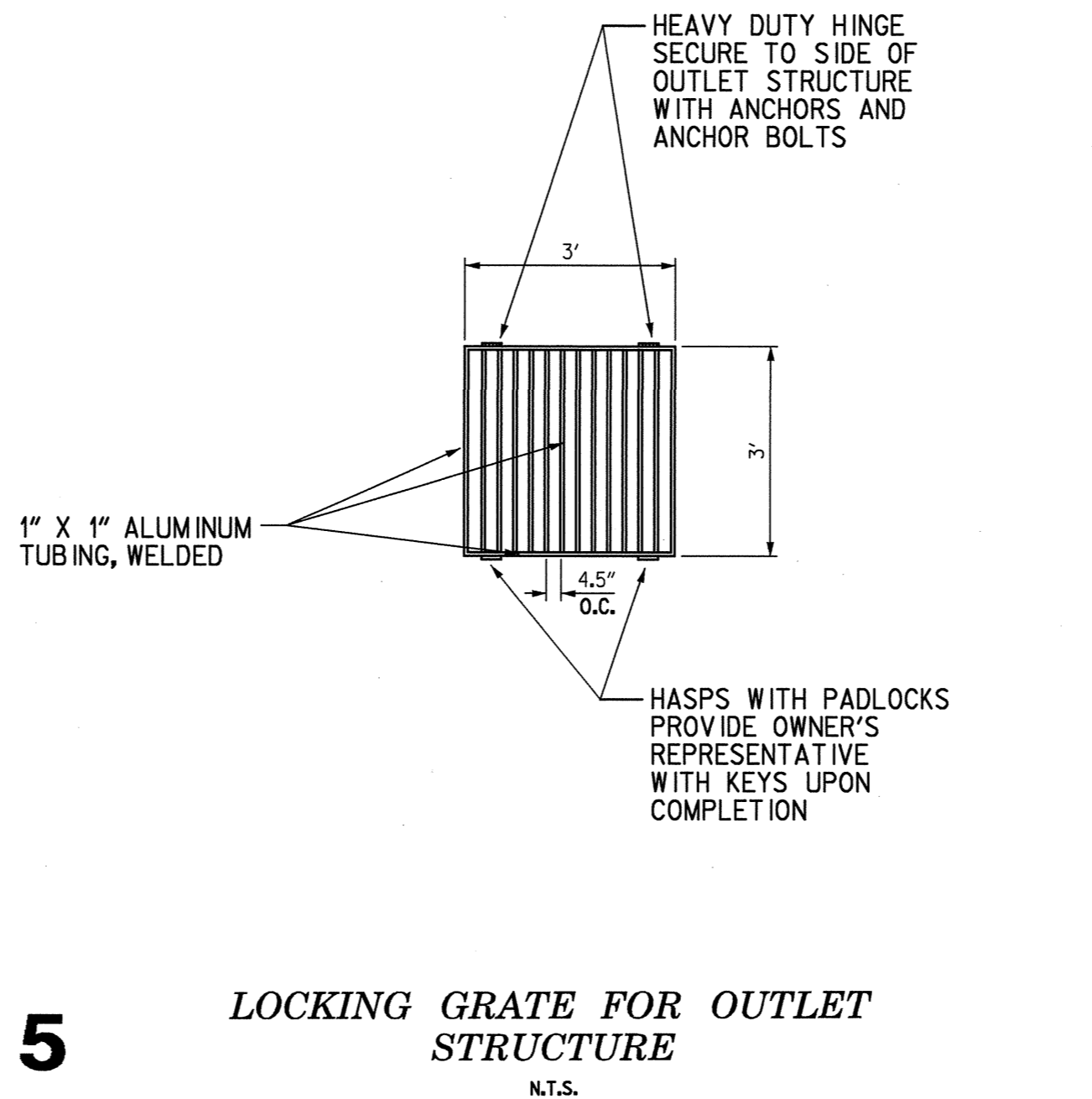

2

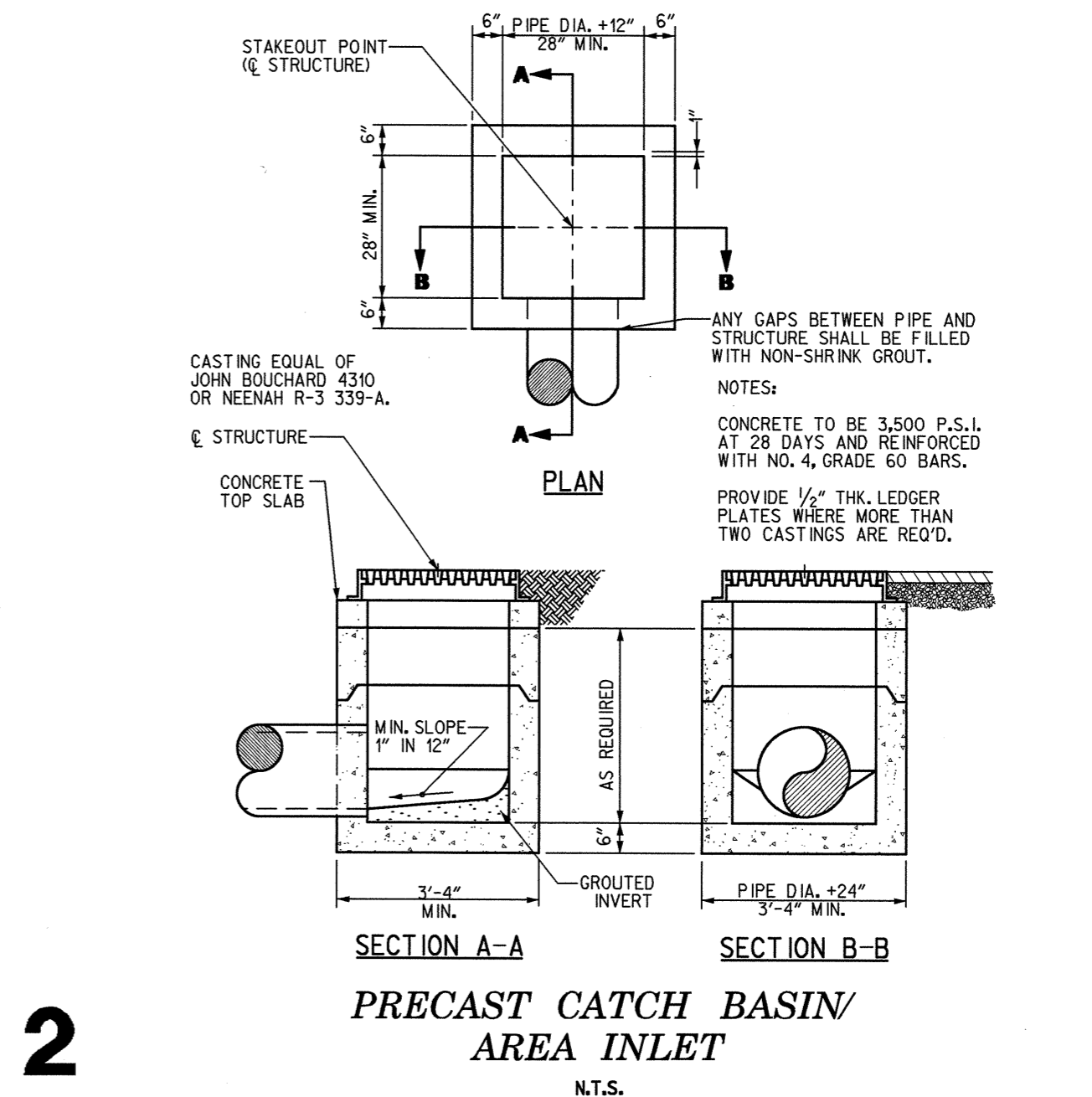

TRUCK EXIT

10

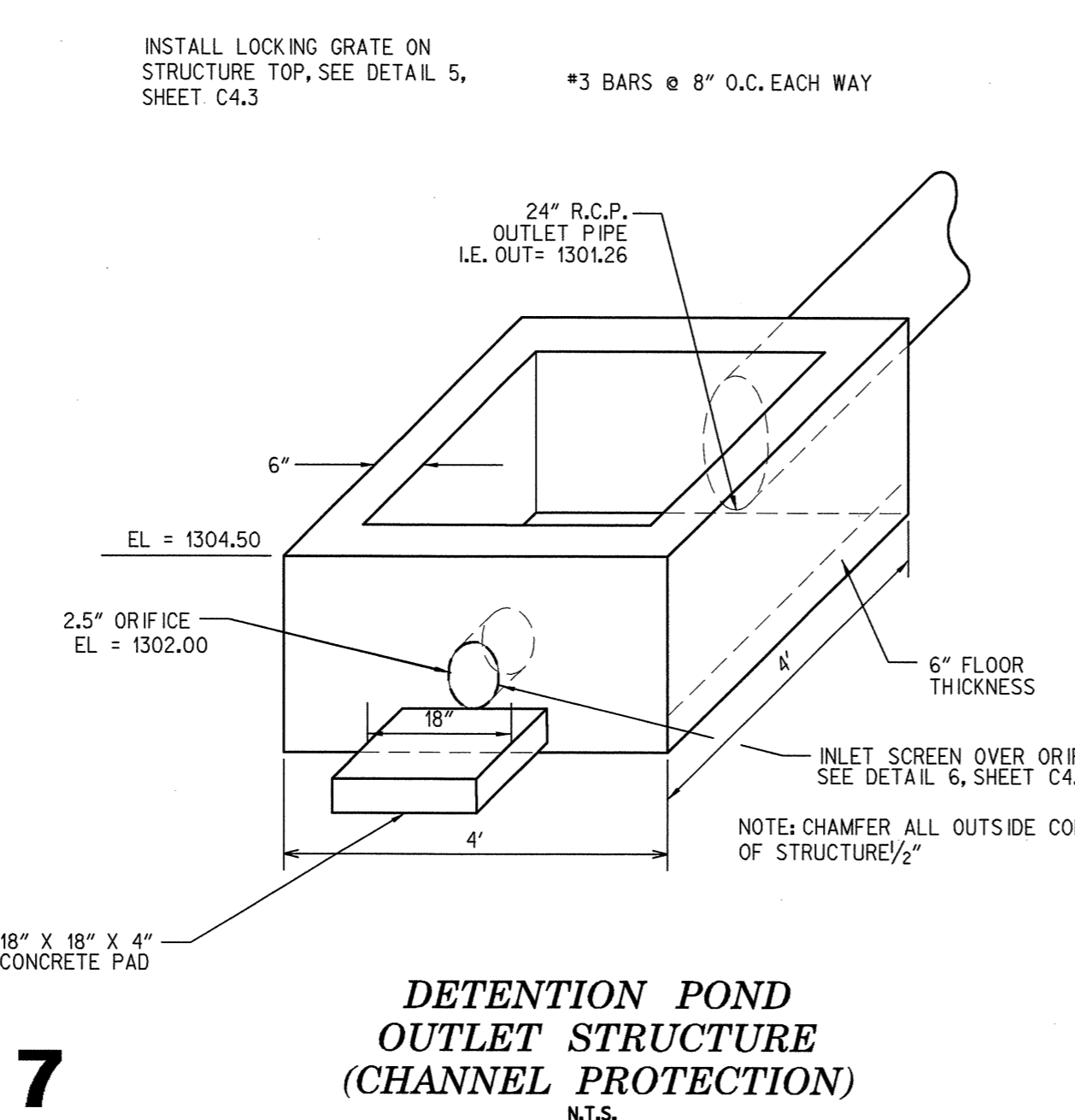

4

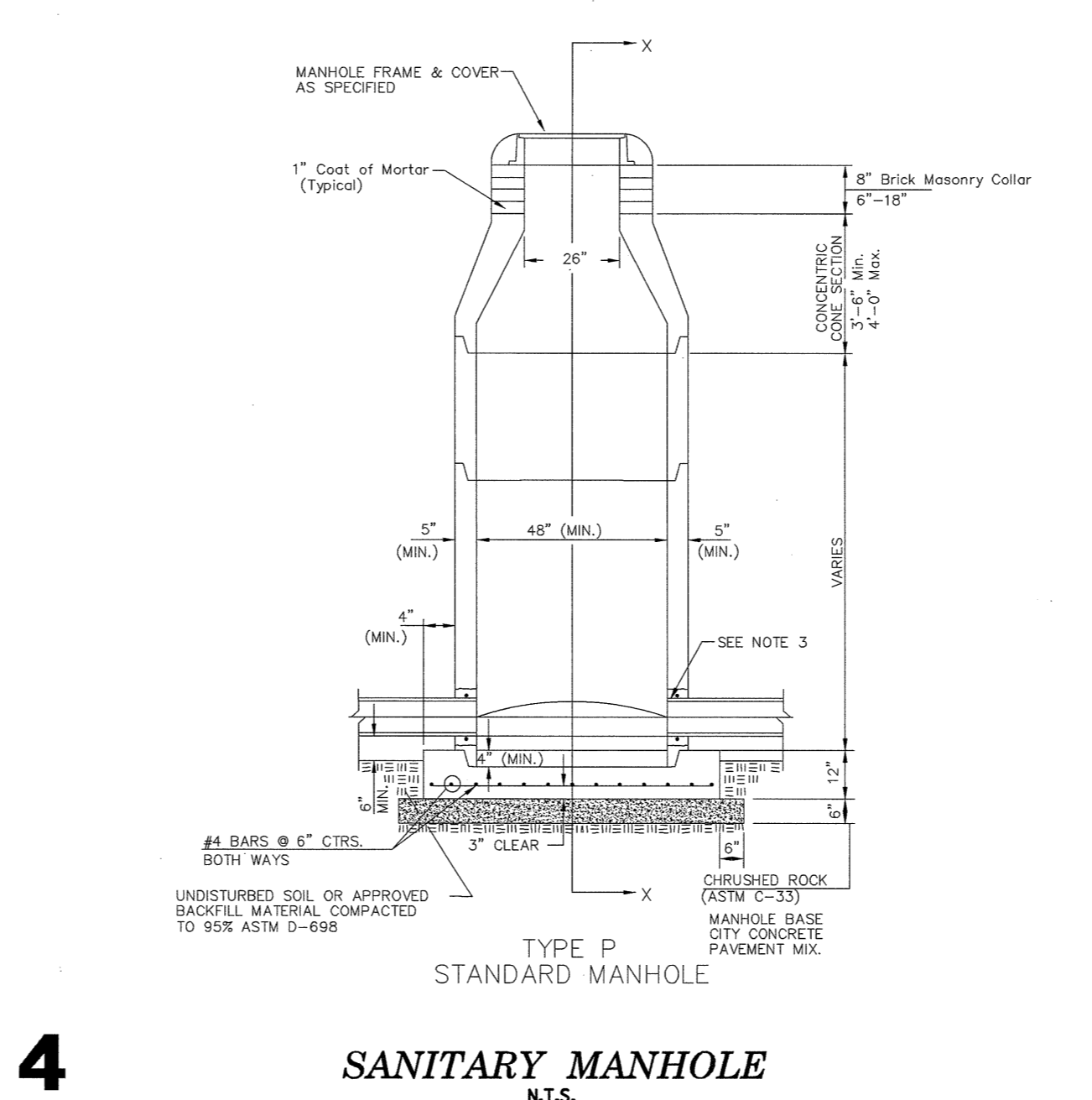

1

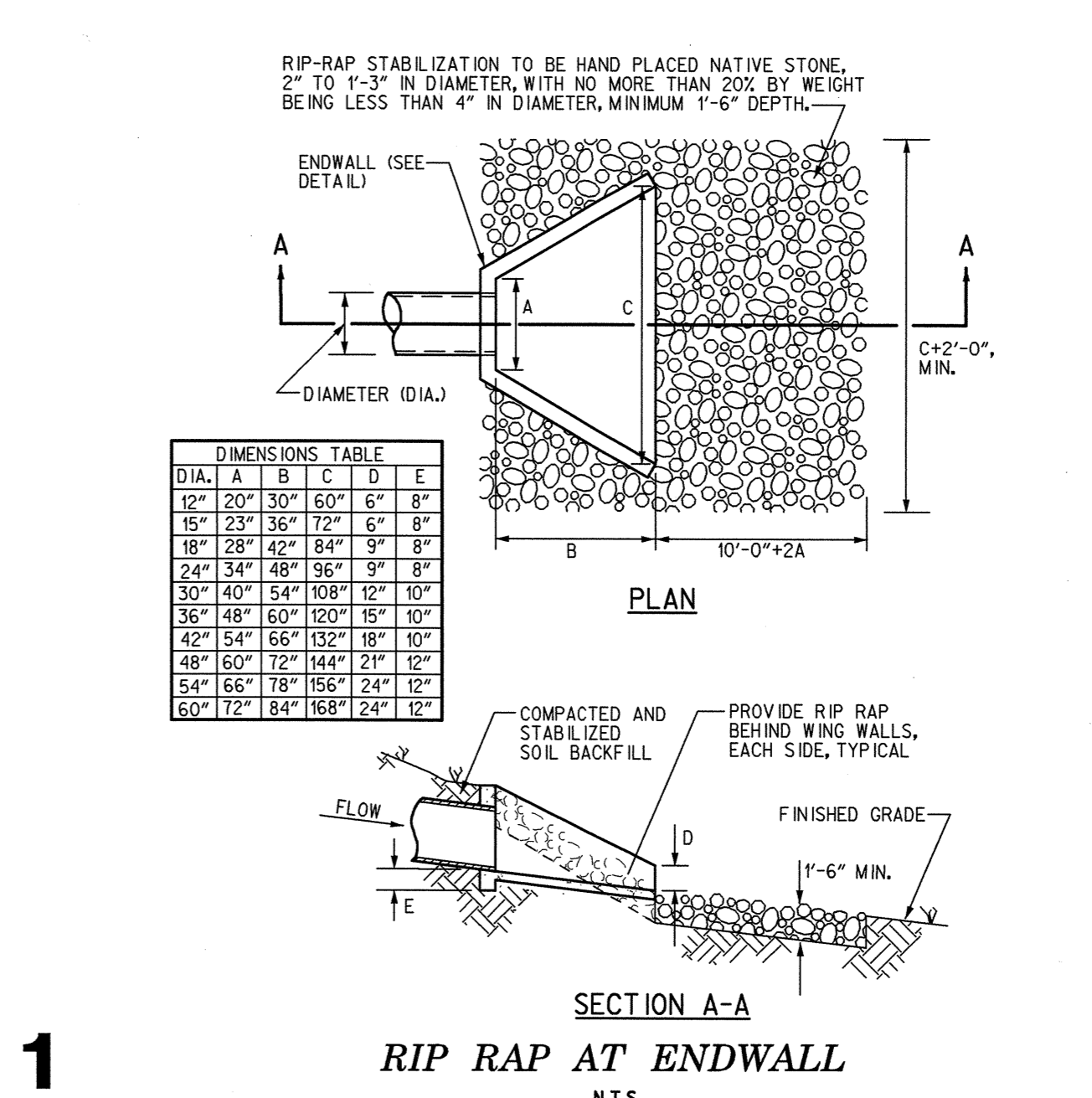

ARCHITECTURE
PLANNING
ENGINEERING
GRAPHICS

105 BROADWAY
4TH FLOOR
NASHVILLE, TN 37201
(p) 615.244.8170
(f) 615.244.8141
www.mjmarcch.com



MICHAEL DUANE HUNKLER
REG.# 15263

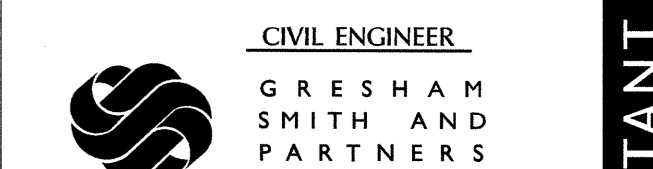

CIVIL ENGINEER
GRESHAM
SMITH AND
PARTNERS

511 Union Street
1400 Nashville City Center
Nashville, Tennessee 37219
Phone: (615)770-8100
CSP #28359.00



GB REALTY CORPORATION
201 Summit Drive Suite 110
Brentwood, TN 37027
615-370-8670
Fax: 615-373-3111
www.gbrealty.com



STORE #: XXXX
WICHITA,
KS AT
PAWNEE

06.07.11
MJM 11074

DATE	CITY COMMENTS
07.05.11	
08.01.11	

This drawing and the design shown is the property of the architect. The reproduction, copying or use of this drawing without their written consent is prohibited and any infringement will be subject to legal action.

SITE DETAILS

C4.3

ARCHITECTS
SEAL
CONSULTANT
OWNER
LOCATION
DATE
SHEET