

Combined Curb & Gutter (6")

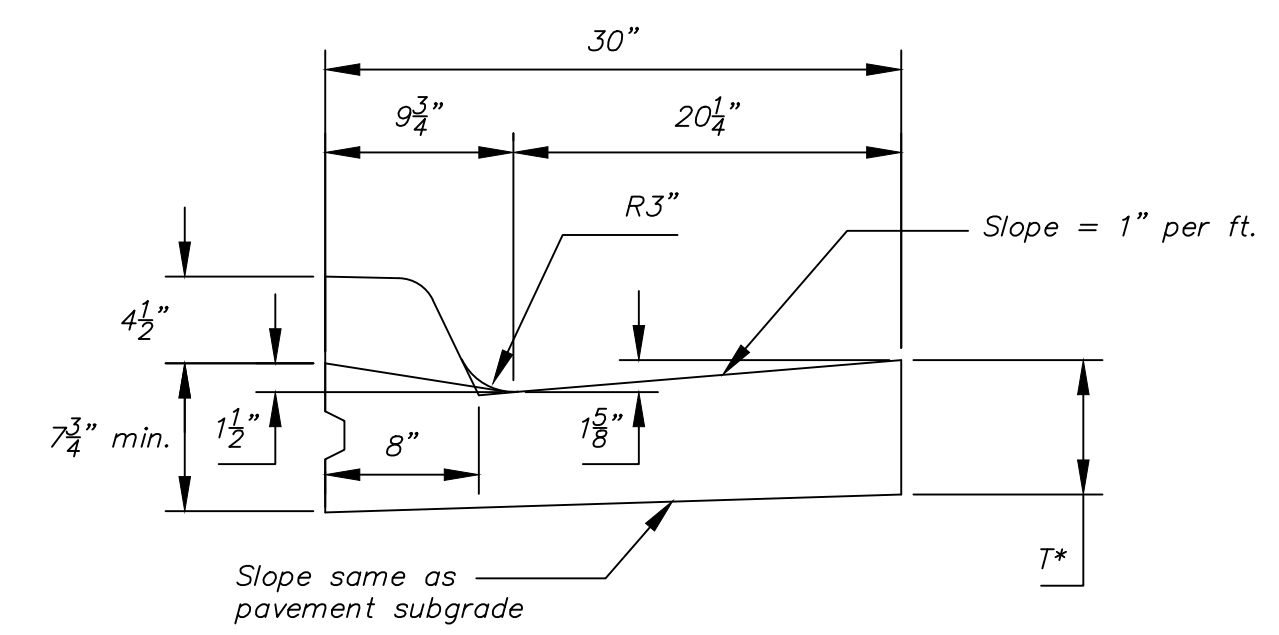

Combined Curb & Gutter (1 1/2")

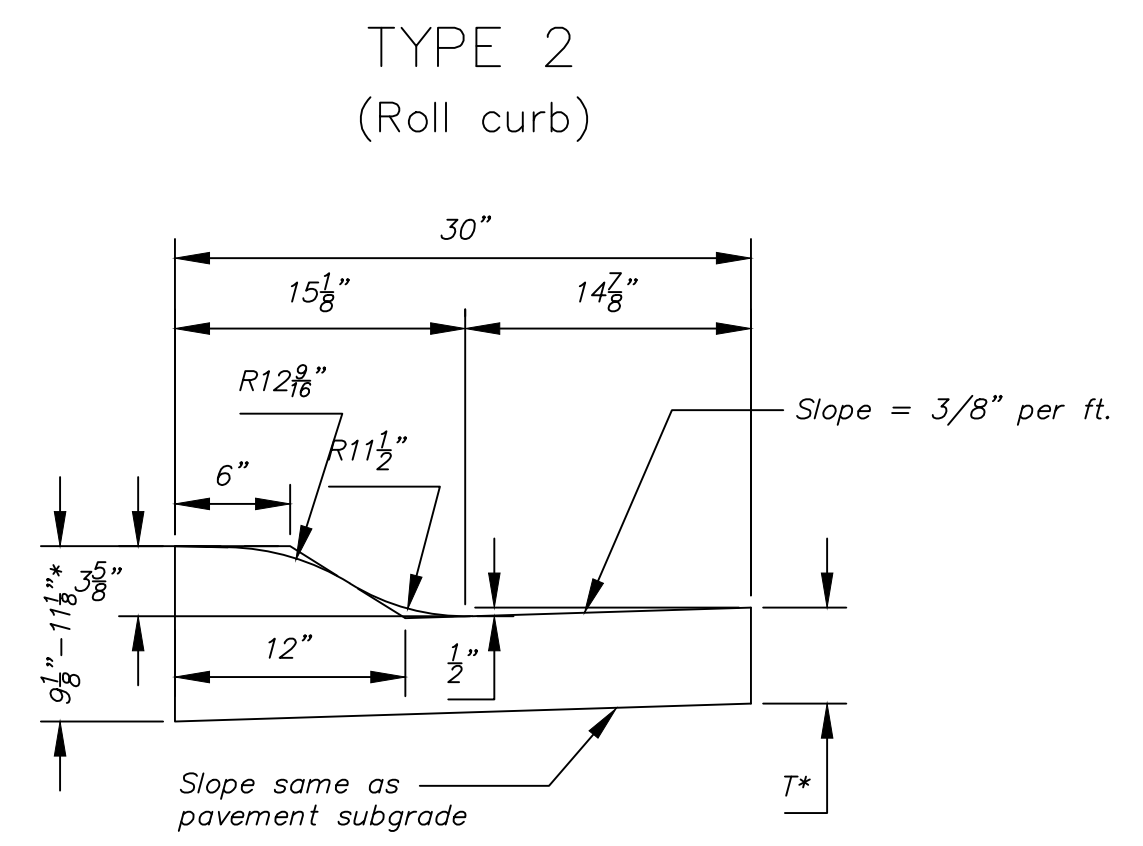

Combined Curb & Gutter (3 5/8")

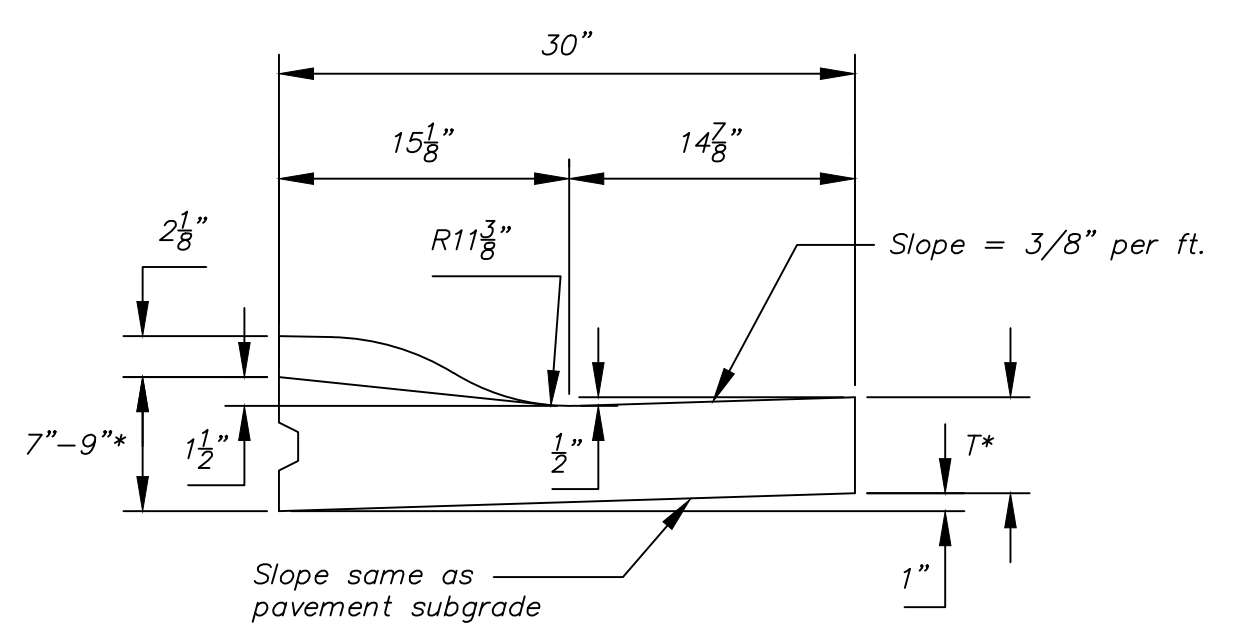

Combined Curb & Gutter (1 1/2")

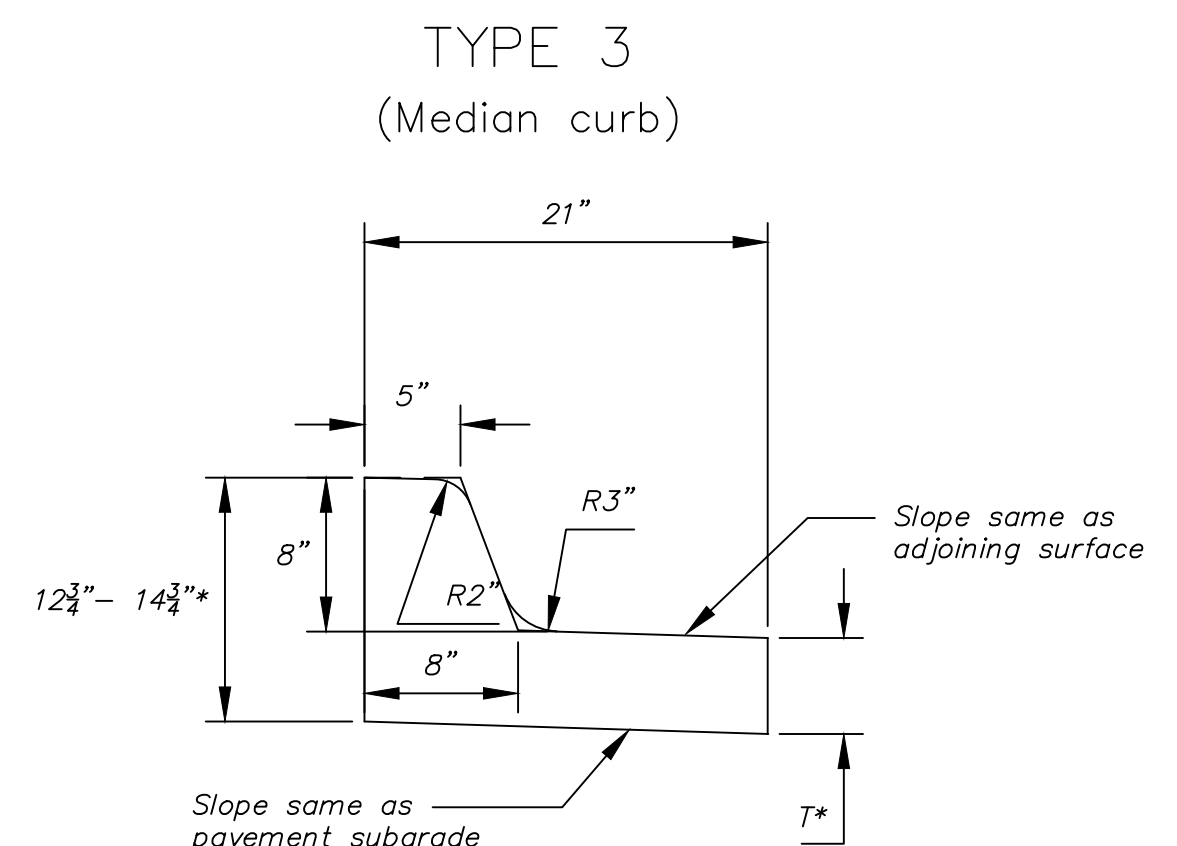

Combined Curb & Gutter (8")

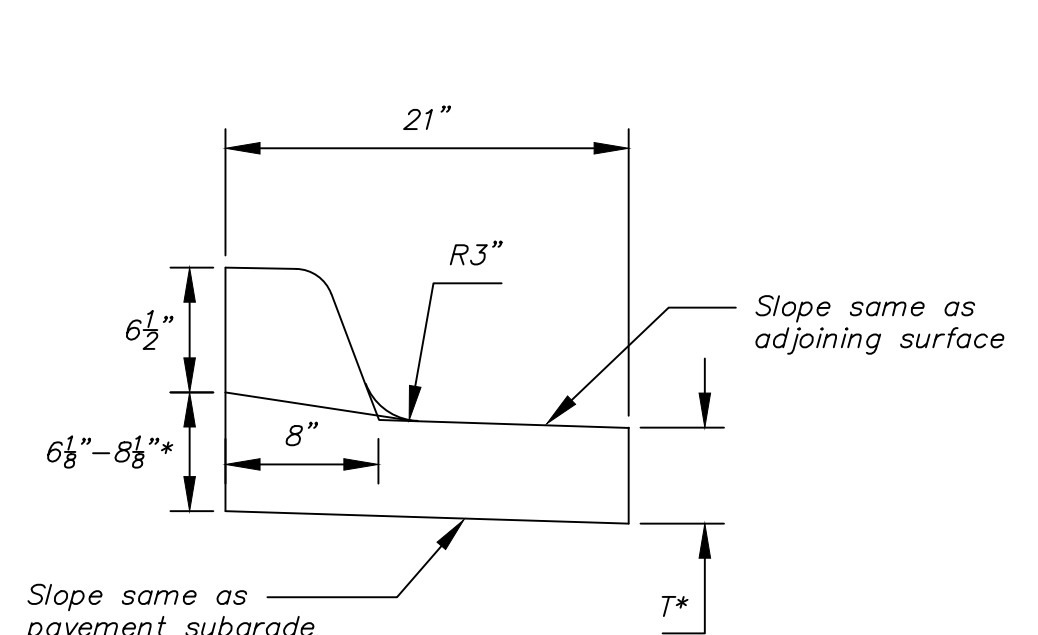

Combined Curb & Gutter (1 1/2")

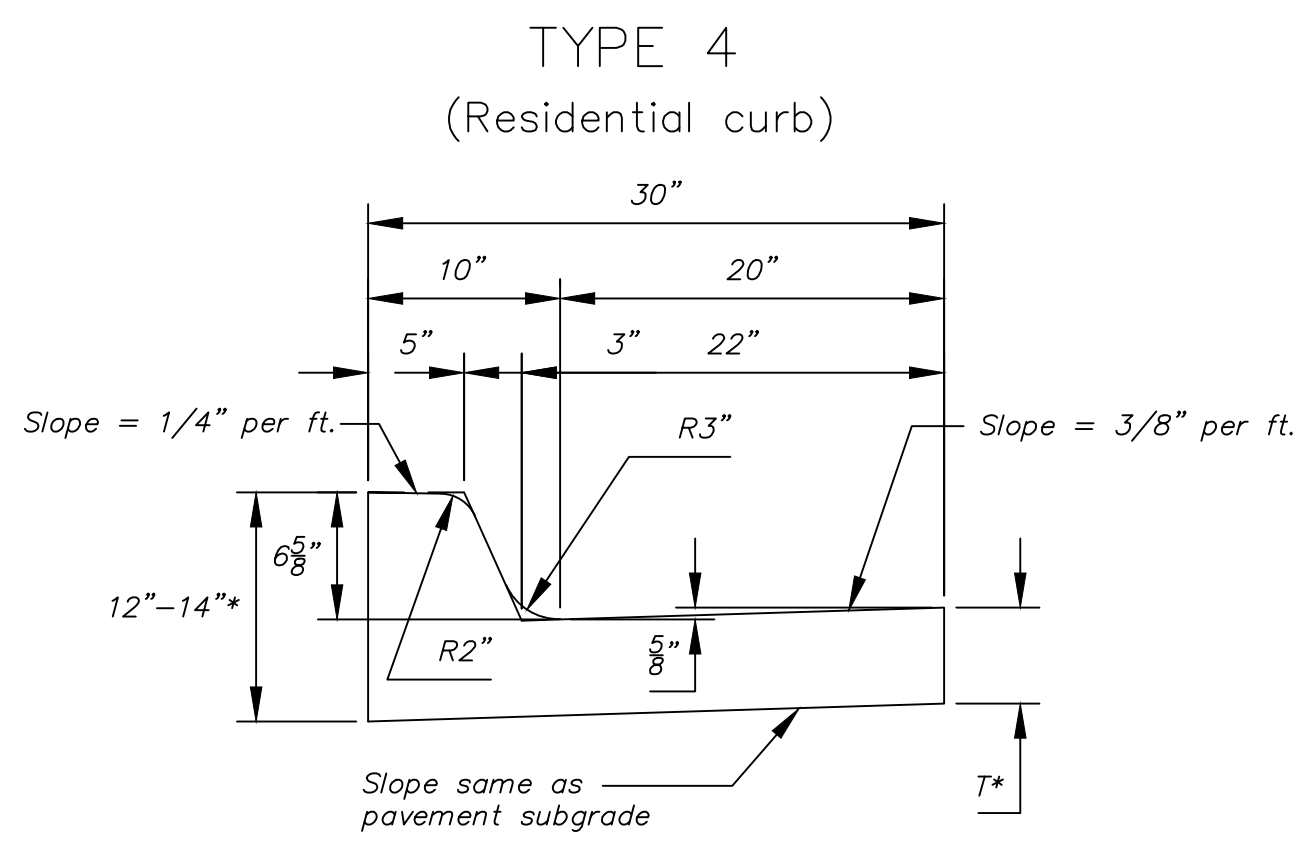

Combined Curb & Gutter (6 5/8")

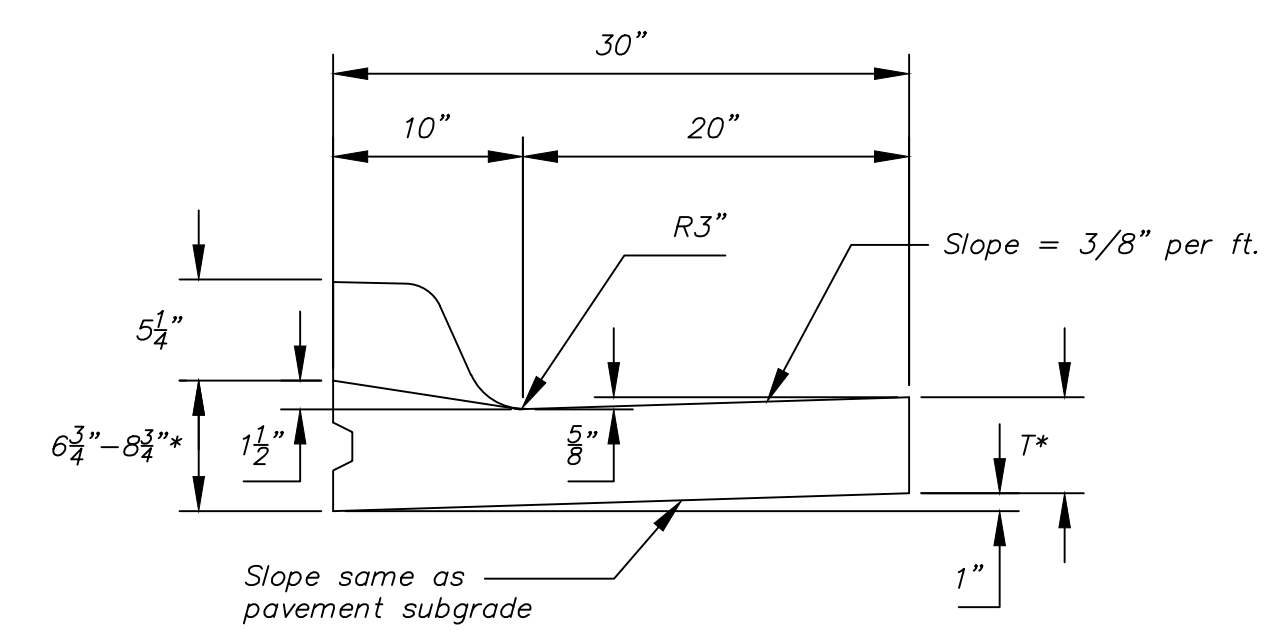

Combined Curb & Gutter (1 1/2")

T\* = Thickness of curb to adjust with pavement thickness

GENERAL NOTES

- Expansion (isolation) joints shall be constructed a maximum of 300' apart and at all PIs, PCs, cul-de-sac quadrants, and ends of returns.
- Contraction joints shall be constructed a minimum of 12' apart.
- Joint sealer shall be required at all joints on arterial and industrial streets and at intersections on residential streets.

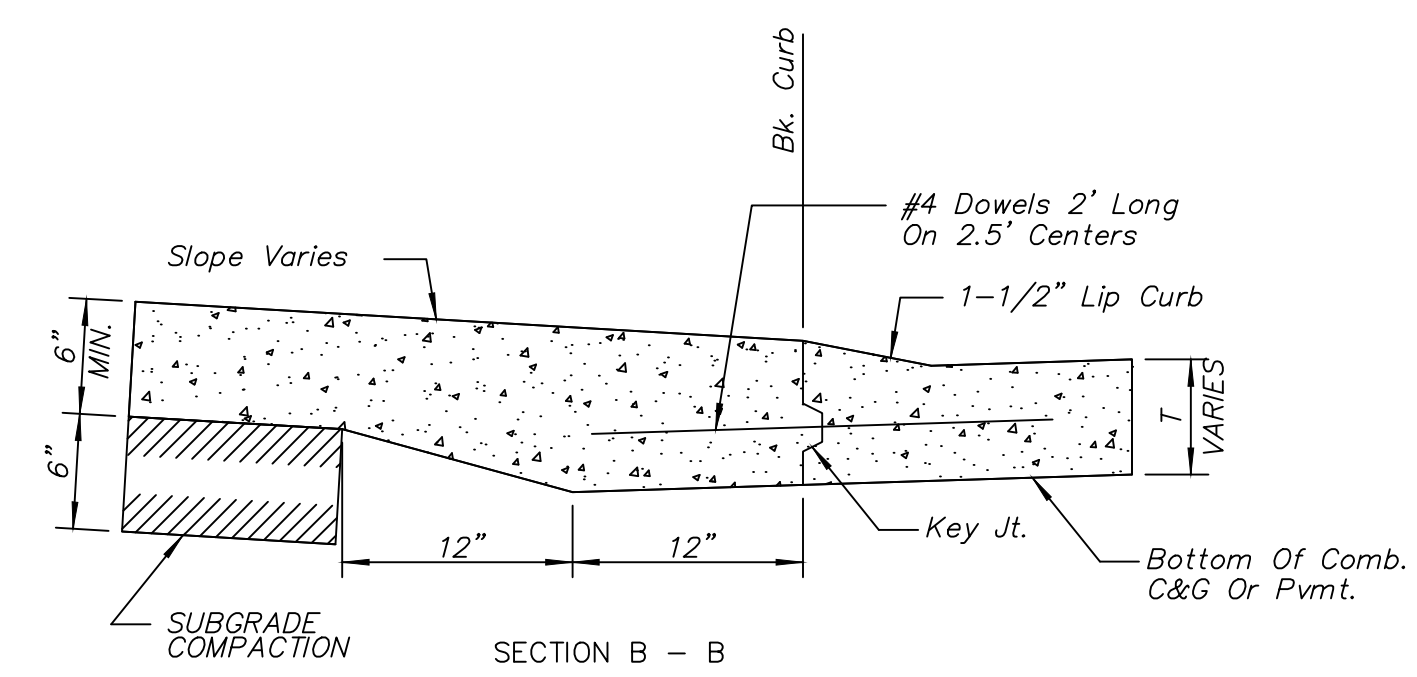

BACK OF CURB DETAIL

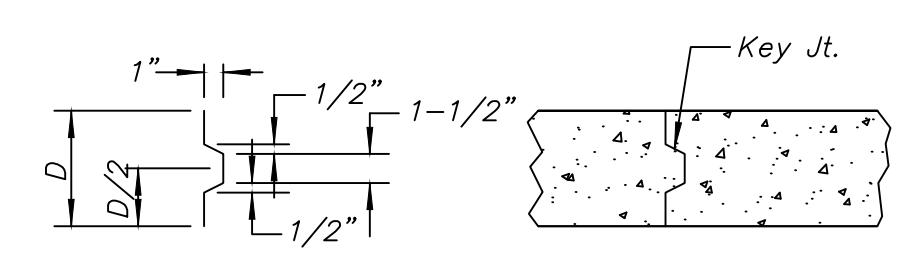

ALT. LONGITUDINAL CONSTRUCTION JOINT

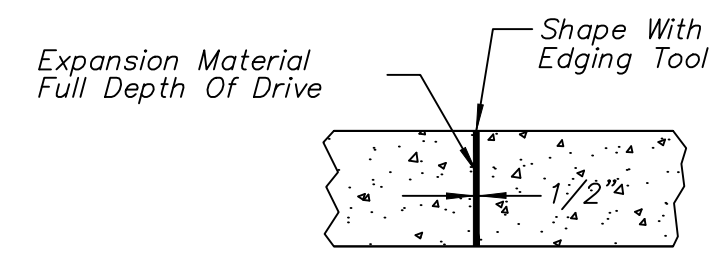

EXPANSION JOINT (E.J.)



CURB & GUTTER DETAILS		
CITY ENGINEER <b>JAMES L. ARMOUR, P.E., L.S.</b>		
PROJECT NUMBER 472 - 84320	OCA NUMBER 706933	DATE 12/2010
CITY ENGINEER'S OFFICE CITY HALL - SEVENTH FLOOR 455 NORTH MAIN STREET WICHITA, KANSAS 67202-1620 (316) 268-4501		DESIGN JPD DRAWN MLT SHEET 85 of 374

No.  Date  Approved   
 13th STREET NORTH FROM KANSAS TO OLIVER STREET & DRAINAGE IMPROVEMENTS CURB & GUTTER DETAILS  
 CITY OF WICHITA, KANSAS  
 JAMES L. ARMOUR, P.E. - CITY ENGINEER  
 POE & ASSOCIATES, INC. CONSULTING ENGINEERS  
 5940 E. Central, Suite 200 • Wichita, KS 67208-4242  
 Phone 316/685-4114 • FAX 316/685-4444  
 FINAL  
 Designed By: JPD  
 Drawn By: MLT  
 P.e. Job No.: 1871A  
 Date: March 2012  
 Sheet 85 of 374