

Re-Enforced Concrete Pipe Information									
Pipe Size	Wall Thickness	Weight per ft	Elliptical Equivalent	End Section Information					
				"A"	"B"	"C"	"D"	"E"	"R"
12"	2.0"	100 lbs	----	6.07'	4.07'	2.00'	2.00'	0.33'	0.75'
15"	2.5"	128 lbs	----	6.08'	3.83'	2.25'	2.50'	0.50'	0.92'
18"	2.5"	168 lbs	23"x14"	6.08'	3.83'	2.25'	3.00'	0.75'	1.00'
24"	3.0"	268 lbs	30"x19"	6.12'	2.50'	3.62'	4.00'	0.79'	1.16'
30"	3.5"	385 lbs	38"x24"	6.12'	1.64'	4.50'	5.00'	1.00'	1.25'
36"	4.0"	524 lbs	45"x29"	8.14'	2.89'	5.25'	6.00'	1.25'	1.66'
42"	4.5"	684 lbs	53"x34"	8.16'	2.92'	5.25'	6.50'	1.75'	1.83'
48"	5.0"	868 lbs	60"x38"	8.16'	2.16'	6.00'	7.00'	2.00'	1.83'
54"	5.5"	1070 lbs	68"x43"	8.18'	2.77'	5.42'	7.50'	2.25'	2.00'
60"	6.0"	1290 lbs	----	8.25'	3.25'	5.00'	8.00'	2.92'	2.00'
66"	6.5"	1540 lbs	----	----	----	----	----	----	----
72"	7.0"	1800 lbs	----	8.25'	1.75'	6.50'	9.00'	3.00'	2.00'
84"	----	----	----	9.25'	1.75'	7.54'	10.00'	3.00'	2.00'

all measurements approximate

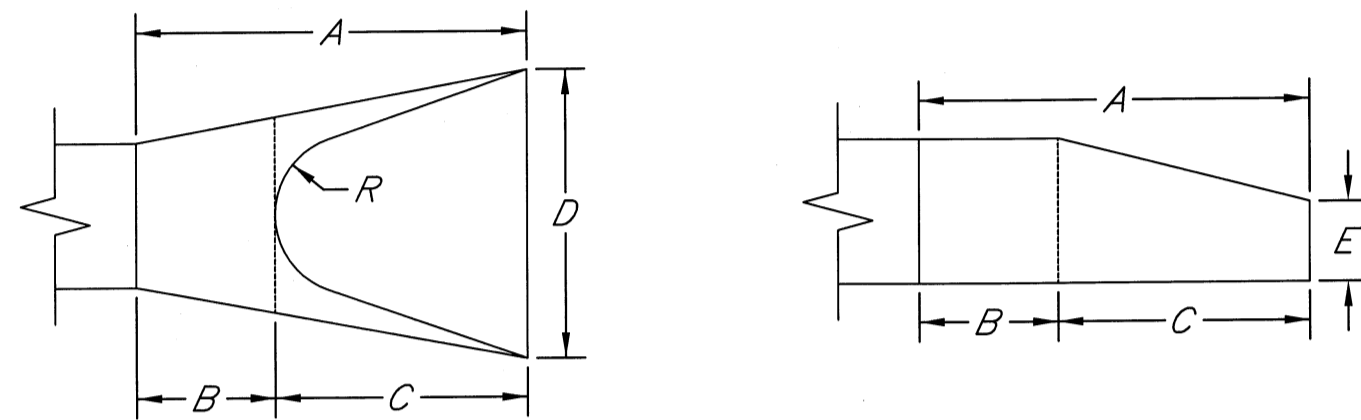

GRADATION REQUIREMENTS:

- Heavy Stone Riprap:** Heavy stone riprap shall be constructed twenty-four inches (24") in thickness and shall be placed on a stone filter course backing having a thickness of nine inches (9"). Stone used in riprap shall meet the required quality requirements and the following size requirements.

Weight of Individual Pieces	Minimum Percent Larger Than
1,000 lbs	0%
500 lbs	50%
75 lbs	90%

Filter course backing for heavy stone riprap shall be produced from the stone meeting the quality requirements of stone for riprap and shall have the following size requirements

Sieve Size	Percent Retained
6"	0%
5"	5-25%
2"	40-60%
3/8"	75-95%

- Light Stone Riprap:** Light stone riprap shall be constructed eighteen inches (18") in thickness and shall be placed on a stone filter course backing having a thickness of six inches (6"). Stone used in riprap shall meet the required quality requirements and the following size requirements.

Weight of Individual Pieces	Minimum Percent Larger Than
500 lbs	0%
250 lbs	50%
125 lbs	70%
10 lbs	90%

Filter course backing for heavy stone riprap shall be produced from the stone meeting the quality requirements of stone for riprap and shall have the following size requirements

Sieve Size	Percent Retained
4"	0%
2"	10-40%
1"	25-60%
3/8"	55-85%
#4	70-95%

INSTALLATION OF STONE RIPRAP:

Stone riprap shall be placed on a prepared bedding layer so as to produce a reasonably well-graded mass with a minimum percentage of void. Stone riprap shall be placed to its full course thickness in one operation without displacing the bedding. Placing stone riprap by dumping into chutes or any other method likely to cause segregation will not be permitted. Placement of stone on the slope and in toe trenches shall be accomplished by controlled dumping directly in place.

Bulldozing of stone from the upper banks will not be permitted, use of a drag line or similar equipment operated from the top of the bank to pull stone into position on the upper slope will be permitted. Stone riprap may be placed below water, providing it is placed by skip or another approved method which will prevent segregation. Larger stones should be distributed and the entire mass of stones in their final position should be stable and free of pockets of small stones and clusters of larger ones; rearrangement of individual pieces by hand may be required to obtain the results described above. A tolerance of plus three inches (3") from the lines and grades shown on the continuous over an area greater than 100 square feet. Hand placing of riprap stones shall be necessary to produce reasonably true surfaces and close fit of stones. The larger spaces between the stones shall be fitted with spalls of suitable size, rammed thoroughly in place. The spaces between stones shall be fitted with smaller rock, carefully hand placed in such a manner to obtain a tight surface.

Toewalls shall be installed along all unprotected edges of edges of stone riprap construction. Such toewalls shall be constructed using the same size stone specified for the riprap with the toewall thickness being the same thickness as specified for the riprap without the filter course backing. The toewalls shall extend a minimum distance of 2' below the bottom of the filter course backing material and they shall be constructed perpendicular to the top surface of the riprap construction. Toewall construction shall be grouted in place for the full depth from the bottom of the toewall to the top surface of the riprap for the full thickness of the toewall to the top surface of riprap for the full thickness of the toewall.

When specified, all riprap placed within the limits of a dimension of 10' from pipe ends, pipe end sections and headwall structures, as measured from the outside edges of such pipe ends or structures, shall be grouted in place. Other area shall be grouted when indicated by the plans. When grouted stone riprap is required, the spaces between the riprap stones shall be filled with water to form a plastic mix. The grout mixture shall be poured and broomed into the voids around the rock until all such voids are completely filled. Grouted stone riprap will be cured in the same manner as specified in the standard specifications for concrete pavement.

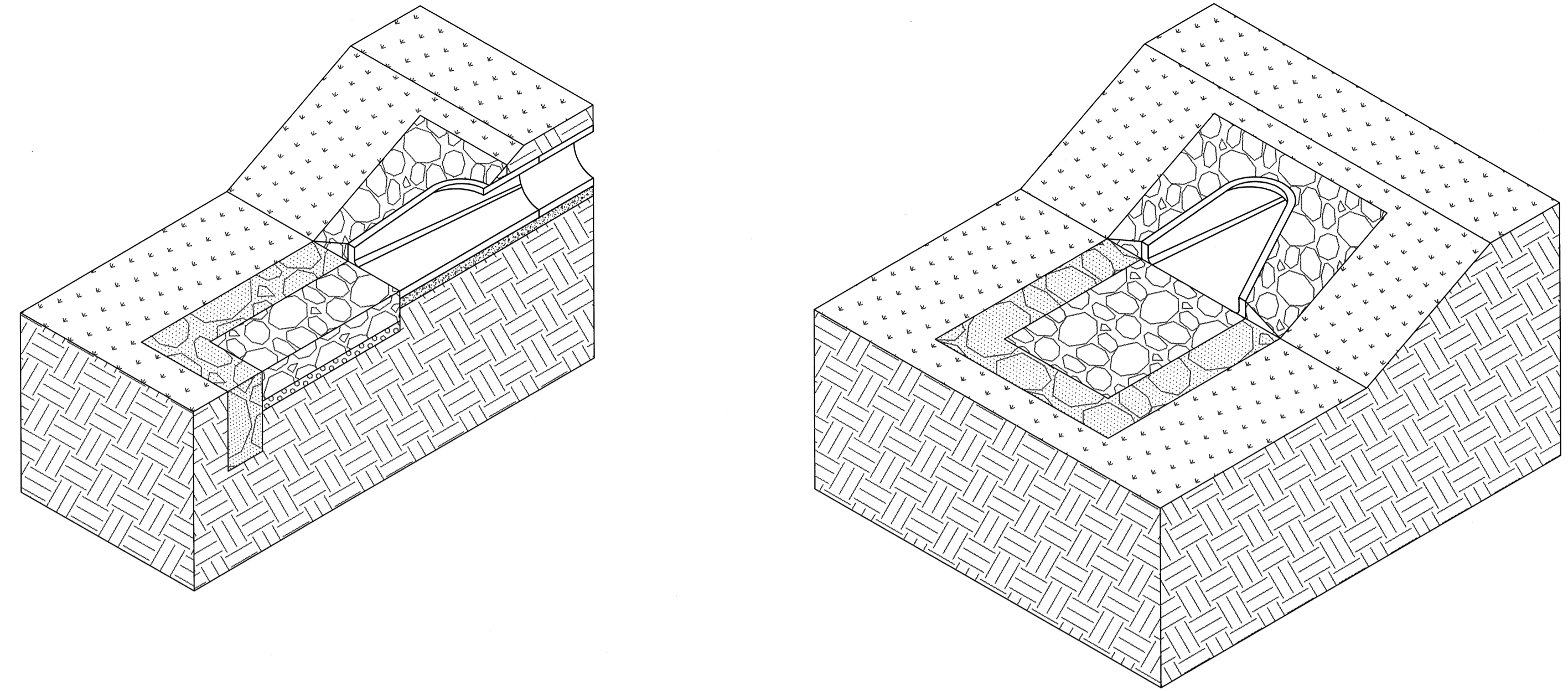

- GROUTED TOEWALL
- STONE RIPRAP
- FILTER COURSE BACKING

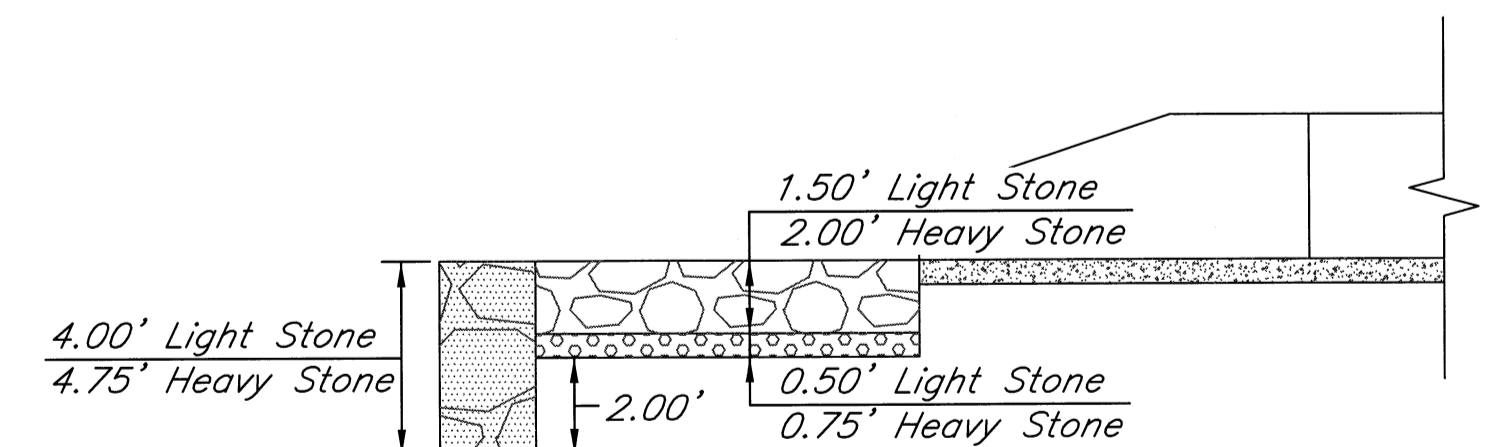
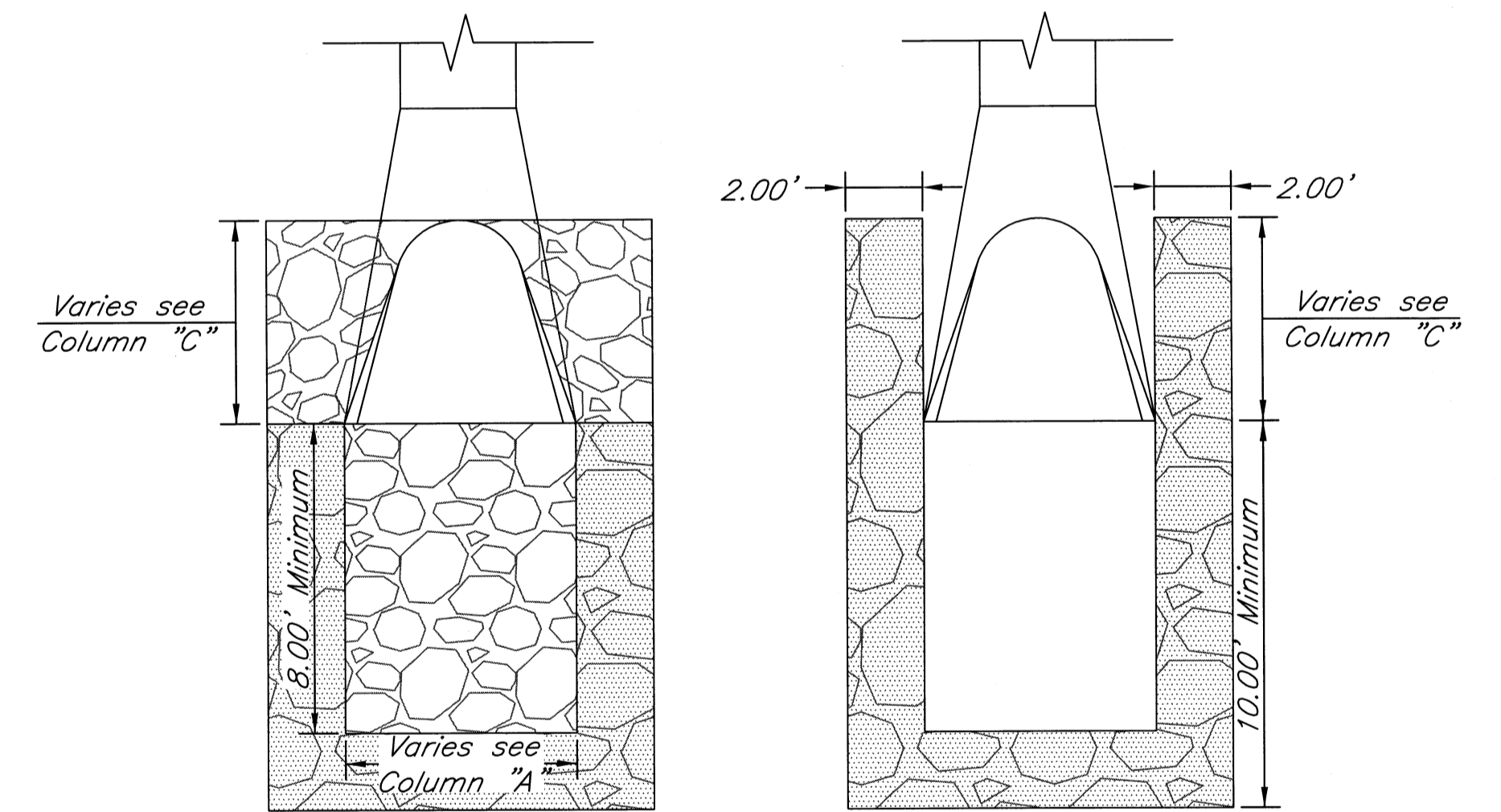

Enterprise Elementary School Rip-Rap Detail Wichita, Kansas			
PROJECT NUMBER 0041 (PPD) 607861			
kemiller engineering	KEM NO. 11011	FILE NS	DATE 07/2011
DESIGN KM	DRAWN NS	REVISED	3.3