

Heavy Duty Inlet Frame and Logo Grate

2816

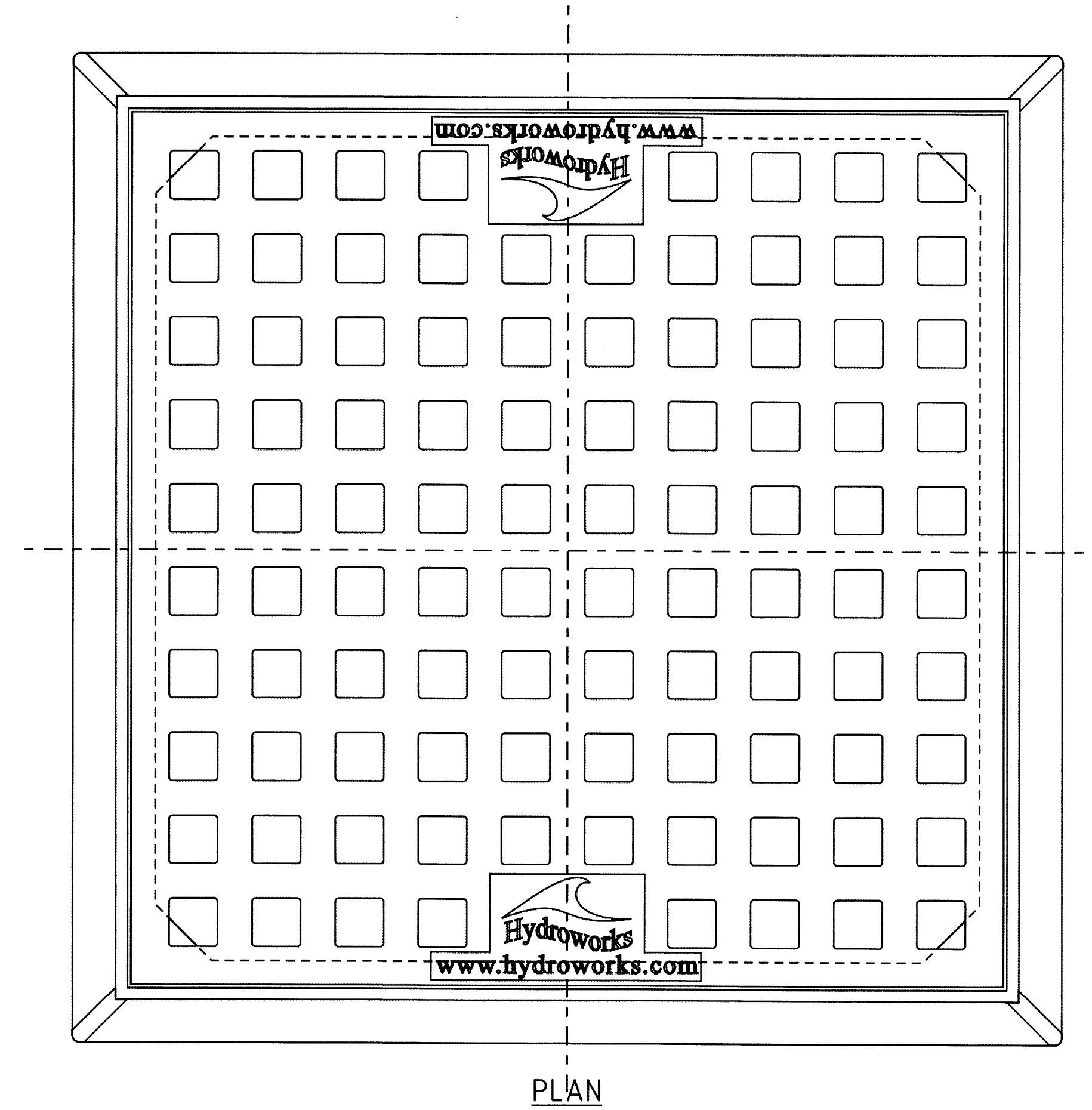

PLAN

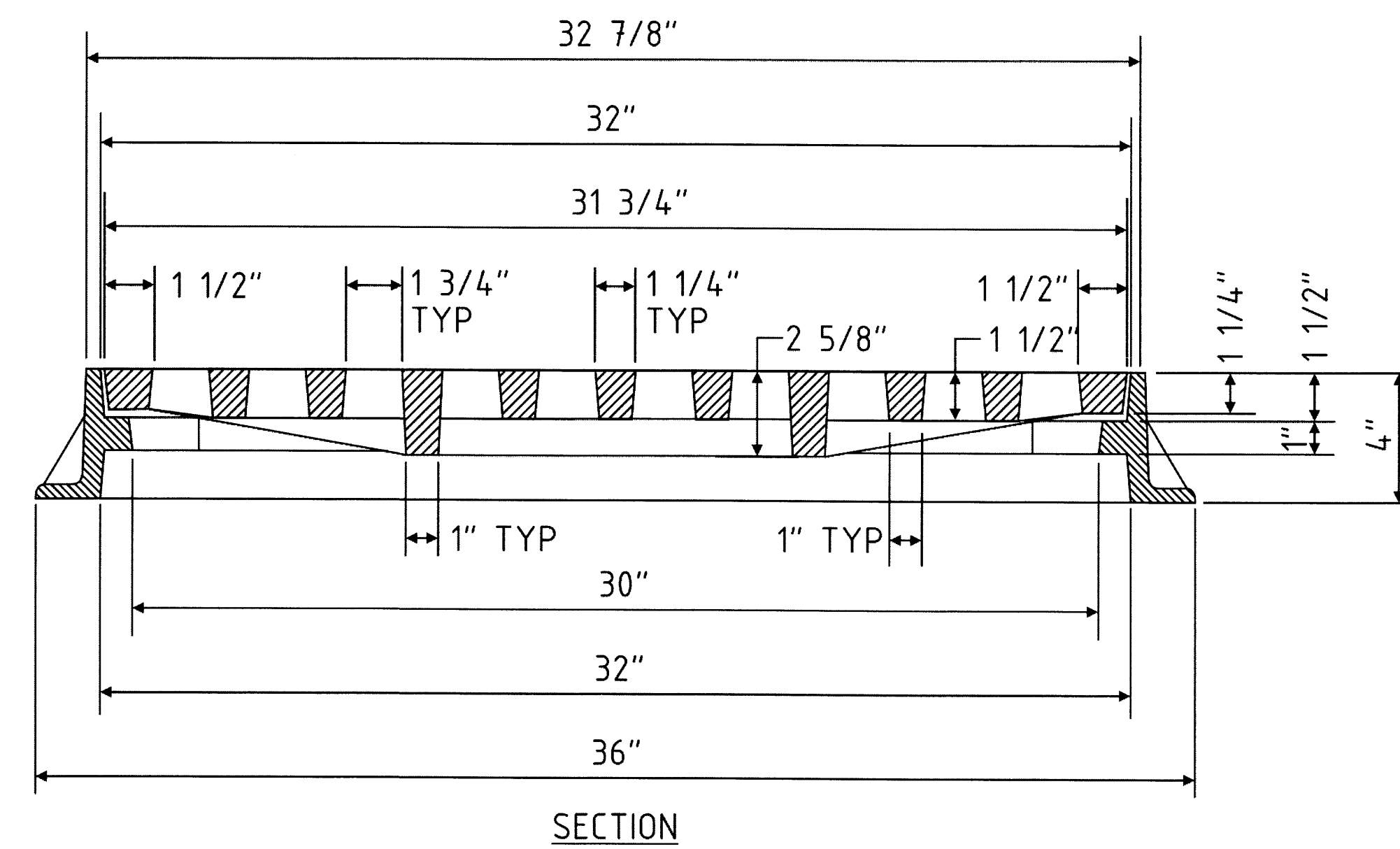

SECTION

Rate of Flow

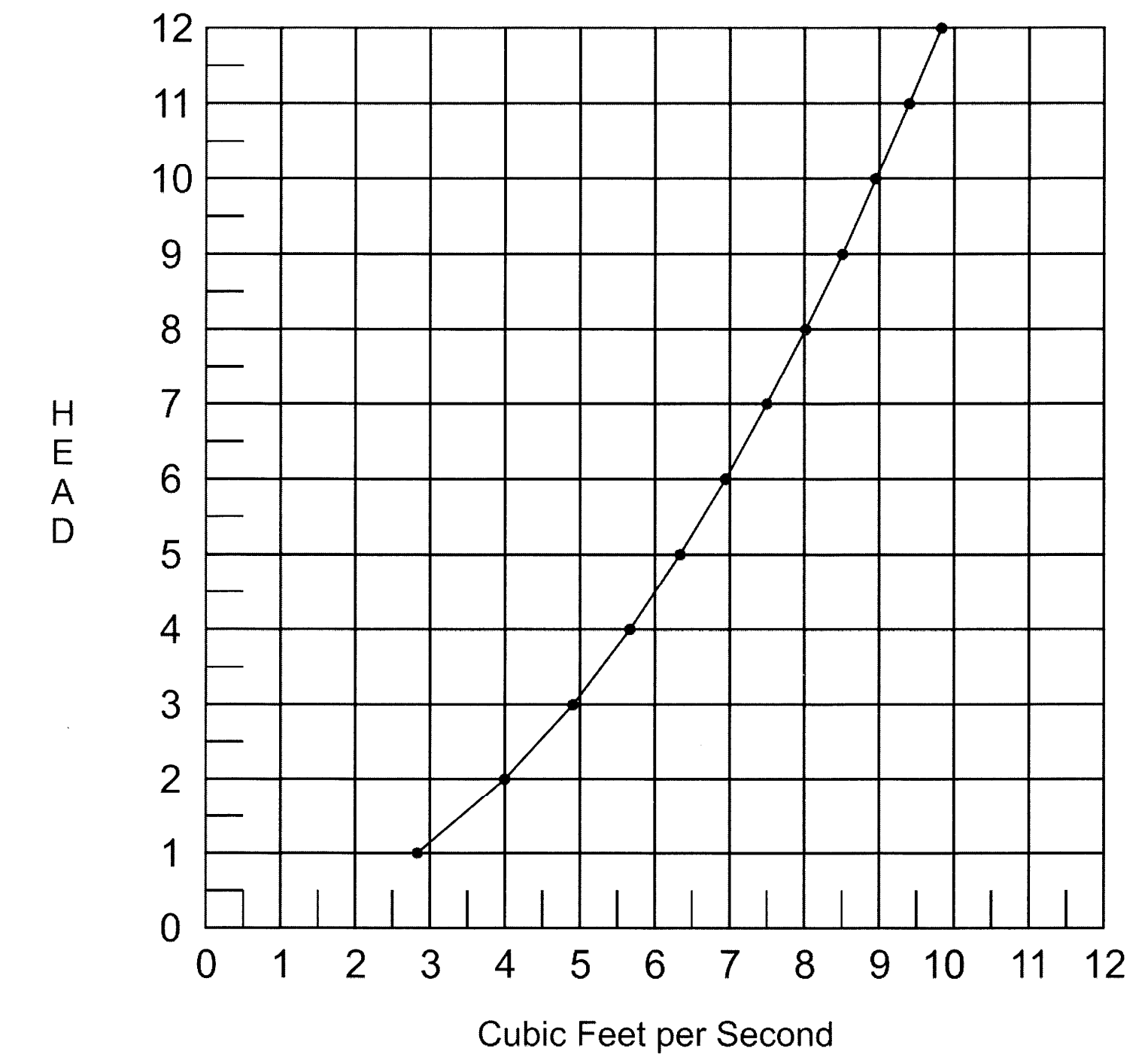

- 1" Head - 2.83 Cu.Ft. per Sec.
- 3" Head - 4.91 Cu.Ft. per Sec.
- 6" Head - 6.95 Cu.Ft. per Sec.
- 9" Head - 8.51 Cu.Ft. per Sec.
- 12" Head - 9.83 Cu.Ft. per Sec.

Notes:

1. Material: Gray Cast Iron, ASTM A48-83, Class 30B;
2. Loading HS25 Highway Loading;
3. Grate shall have 96 - 1 3/4" square hole affording a total open area of 294 Sq. In. (2.04 Sq.Ft.);
4. Logo cast on surface of grate, 180° apart;
5. Castings supplied without surface coating.

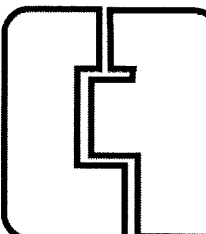
 CAMPBELL FOUNDRY COMPANY Harrison, N.J. 07029 Phone: 973-483-5480 FAX: 973-483-1843		
SCALE:	APPROVED BY:	DRAWN BY: DL
DATE: 02/22/10		REV.:
Heavy Duty Inlet Frame and Logo Grate		
Pattern Number: 2816		Sheet 4 of 4