

**EXPANSION JOINT**

NOTE: Extra Thickness to be Subsidiary to Price of Square Yards Pavement

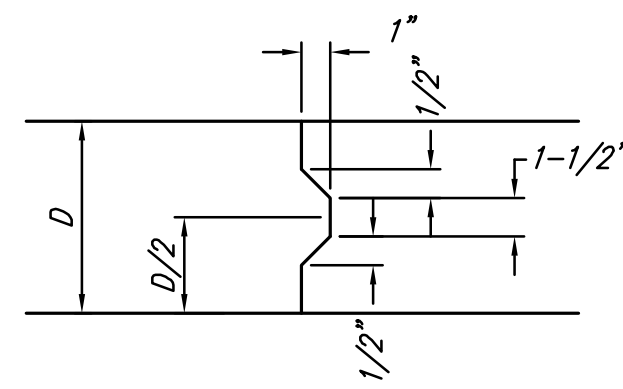

**KEYWAY DETAIL**

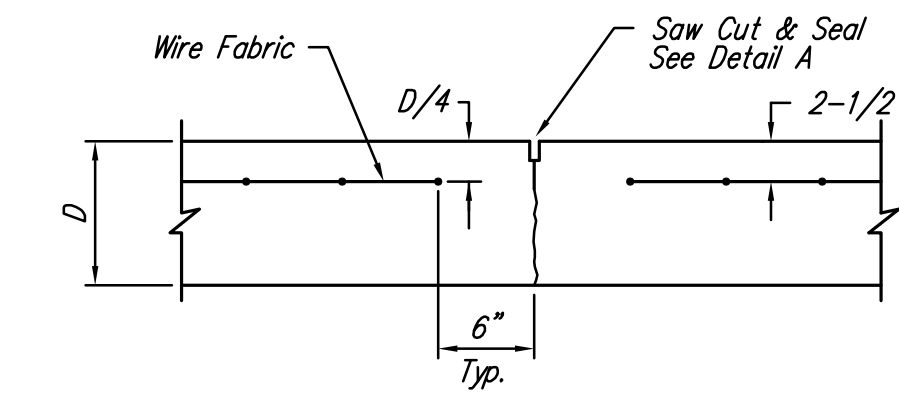

**CONTRACTION JOINT DETAIL (C.J.)**

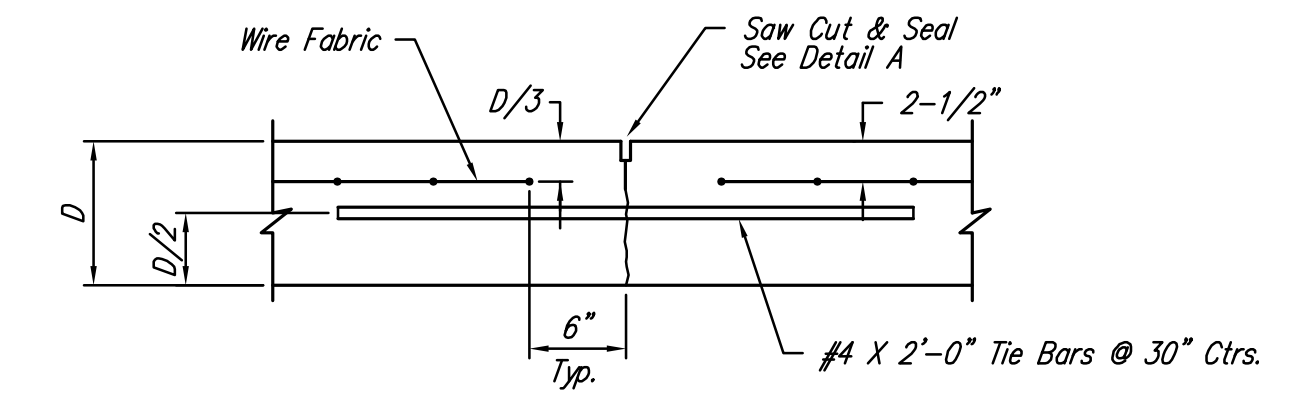

**LONGITUDINAL JOINT DETAIL (L.J.)**

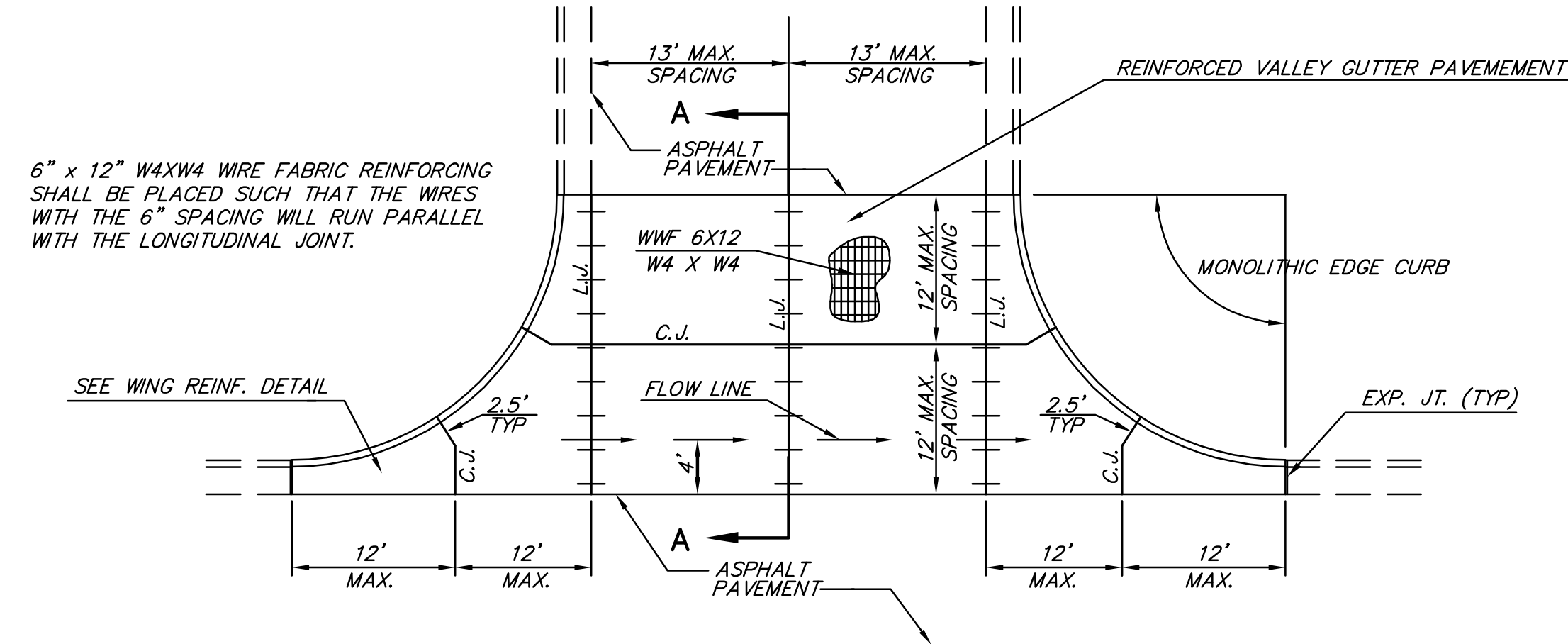

**PLAN**

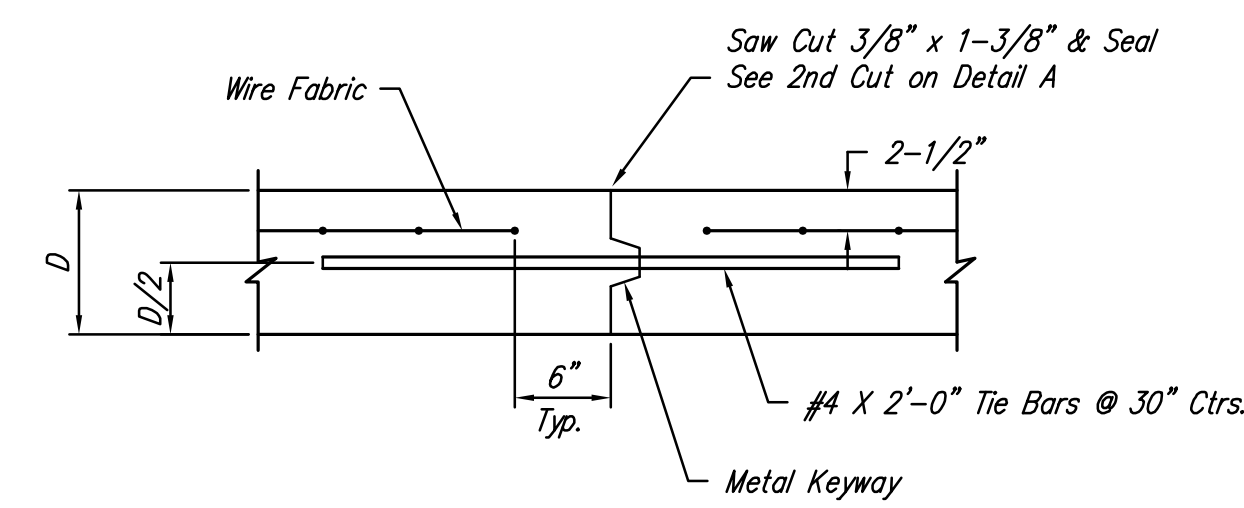

**OPTIONAL CONTRACTION JOINT**

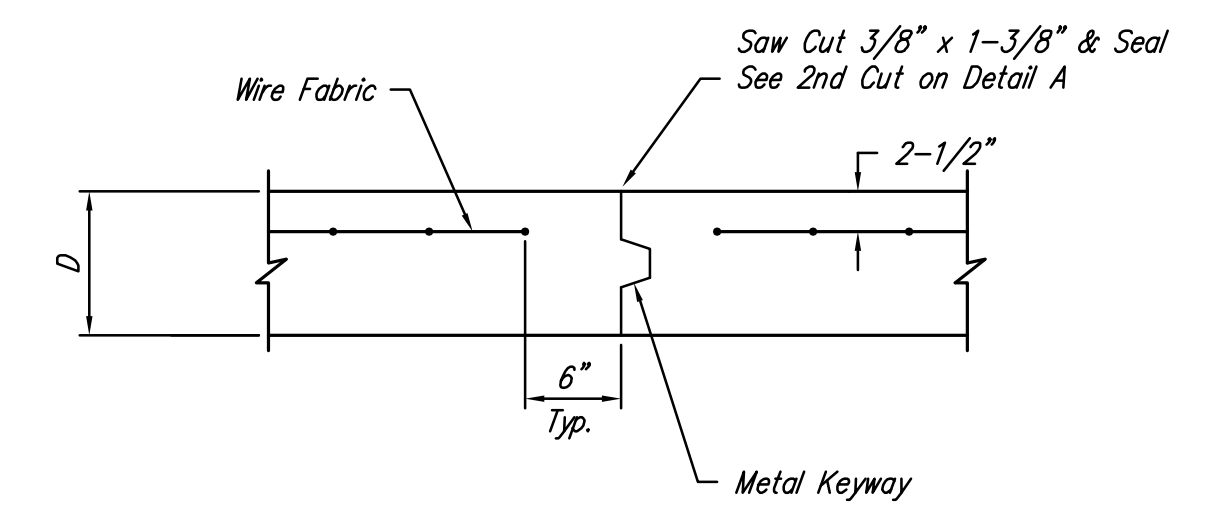

**OPTIONAL LONGITUDINAL JOINT DETAIL (L.J.)**

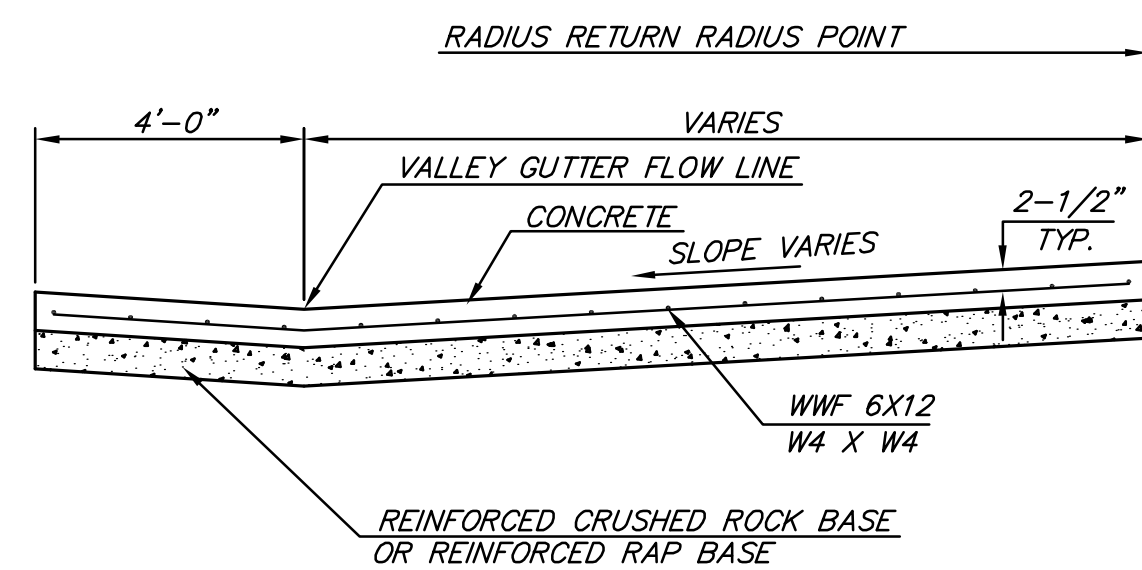

**SECTION A-A**

**REINFORCED VALLEY GUTTER DETAIL**

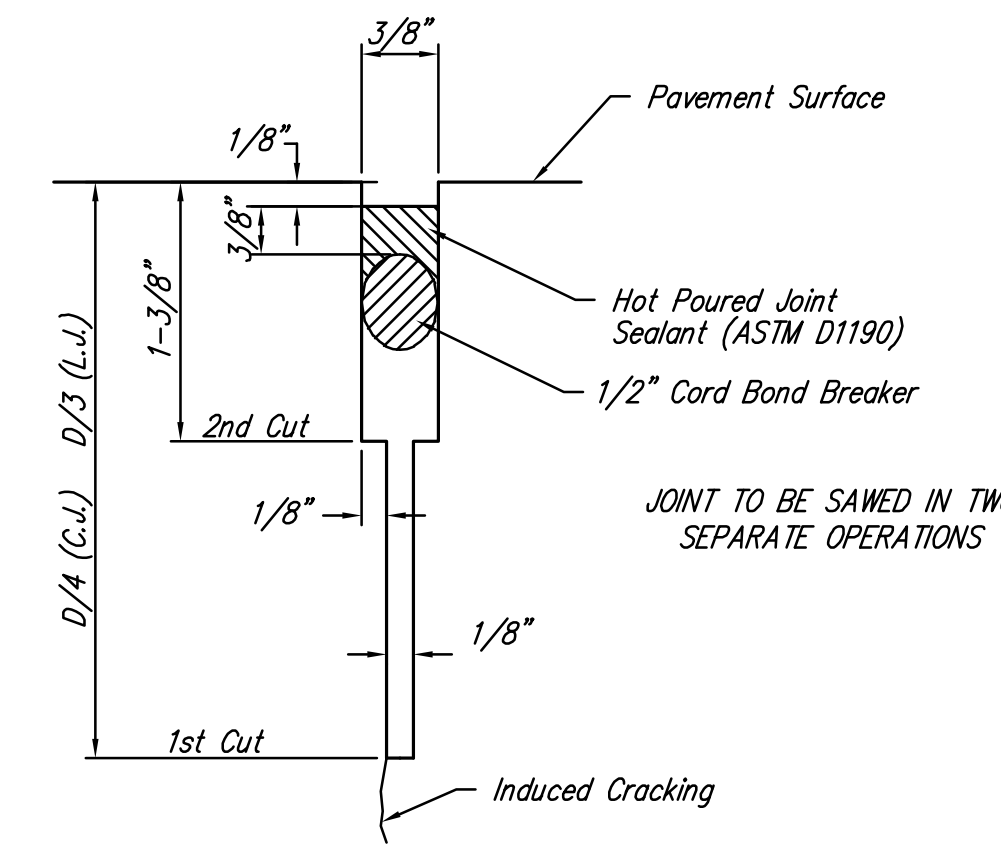

**SAW JOINT DETAIL**

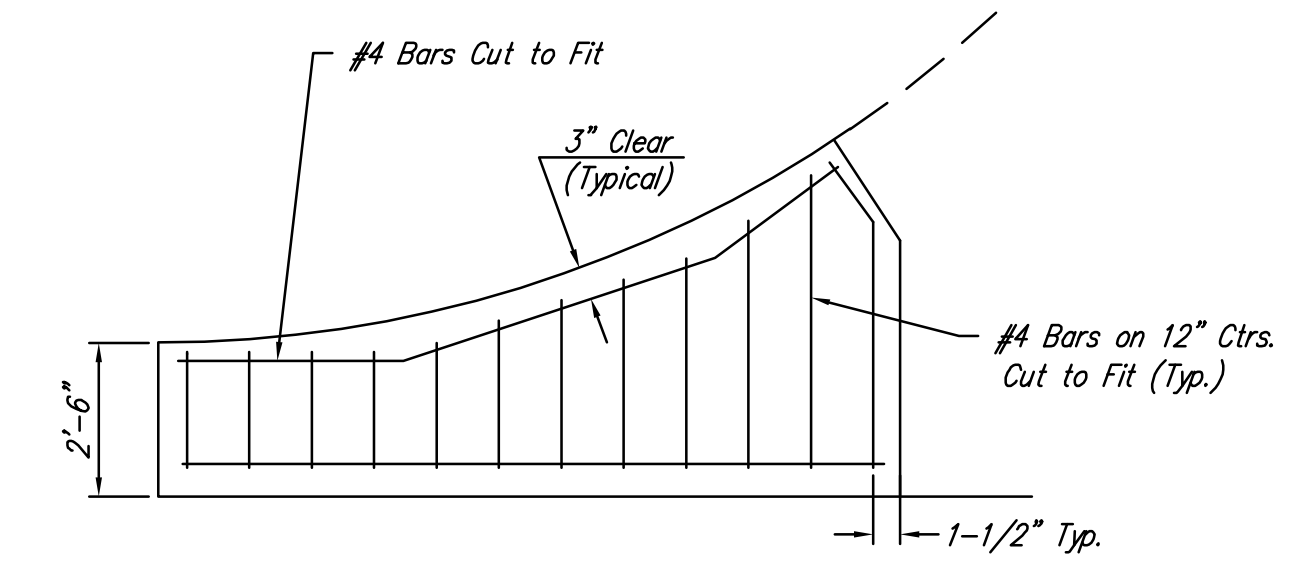

**WING REINFORCING DETAIL**

<p>THE CITY OF WICHITA</p> <p>CITY ENGINEER'S OFFICE CITY HALL - SEVENTH FLOOR 455 NORTH MAIN STREET WICHITA, KANSAS 67202 (316) 268-4501 (316) 268-4114 FAX</p>	<b>VALLEY GUTTER DETAILS</b>	
	GARY L. JANZEN, P.E. - CITY ENGINEER	
	PROJECT NUMBER 472-85061	OCA NUMBER 766285
	DATE Nov 12	<b>Sheet 3 of 11</b>

J:\PROJECTS\2012\1201010125\_OCCIDENTAL\_CRANBROOK\5-CIVIL\CAD\PAV\12125\_ED2.DWG