

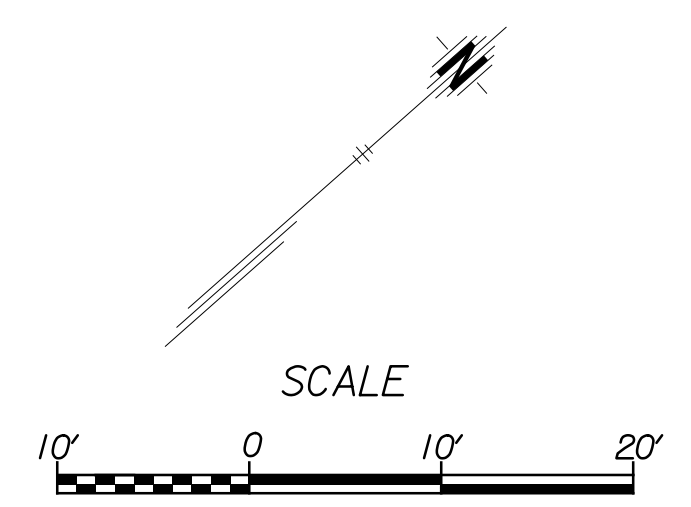

PROJECT NO.	YEAR	SHEET NO.	TOTAL SHEETS
472-84817 PHASE II	2011	26	93

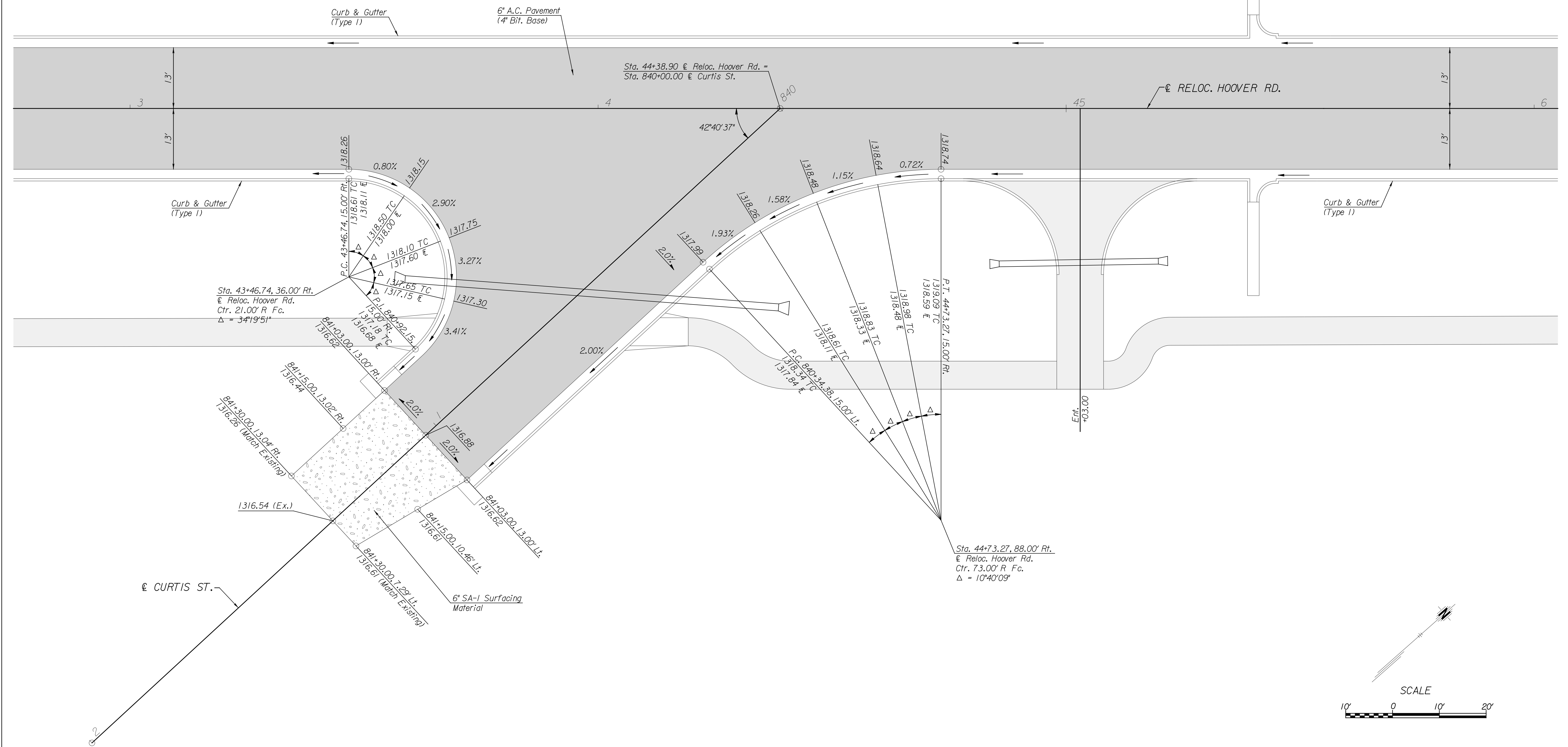

Plotted on: Monday October 24, 2011 09:32 AM
 mbechtel Plot Queue: \\ovpww00\pl\TBWLP
 Plot Scale: 10.000000:0.000000 Pen Tables: \\ovpww00\jobs\4809\Common\Highway\Library\blob\pen\CC-22x35.pen
 Design Filename: \\ovpww00\jobs\4809\Hoover\CD\Detail\Hvr-Intersections.dgn



 CITY OF WICHITA PUBLIC WORKS & UTILITIES ENGINEERING DIVISION	RELOCATED HOOVER RD./ CURTIS ST. INTERSECTION DETAIL		
	CITY ENGINEER JAMES L. ARMOUR, P.E., L.S.		
	PROJECT NUMBER	OCA NUMBER	DATE
	472-84817 PHASE II	770005	11/2011
CITY ENGINEER'S OFFICE CITY HALL - SEVENTH FLOOR 455 NORTH MAIN STREET WICHITA, KANSAS 67202-1620 (316) 268-4501	DESIGN	DRAWN	SHEET
			26 of 93