

PROJECT NO.	YEAR	SHEET NO.	TOTAL SHEETS
472-84817 PHASE II	2011	32	93

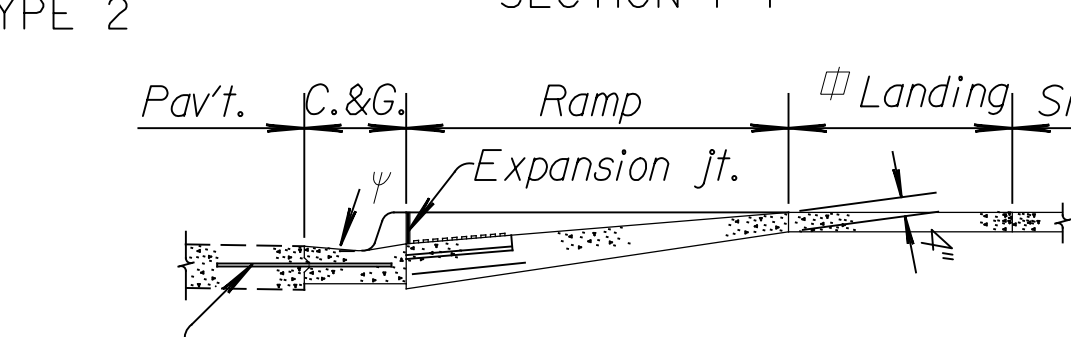

SECTION J-J see standard drawing RD725B for details of Steps and Handrail.

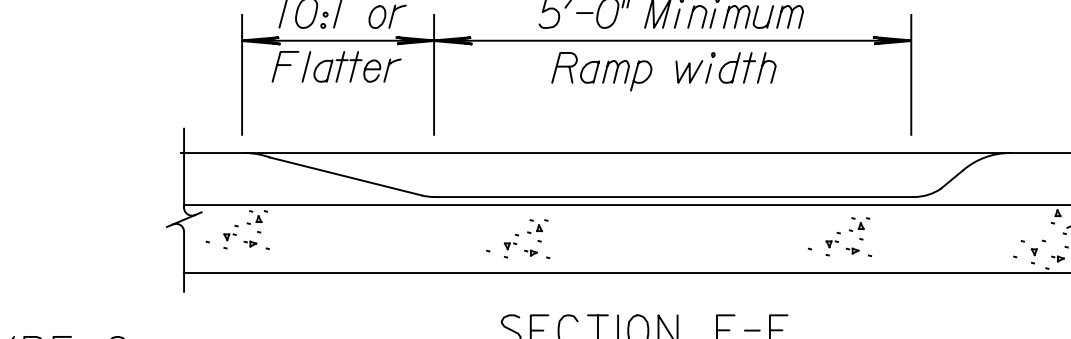
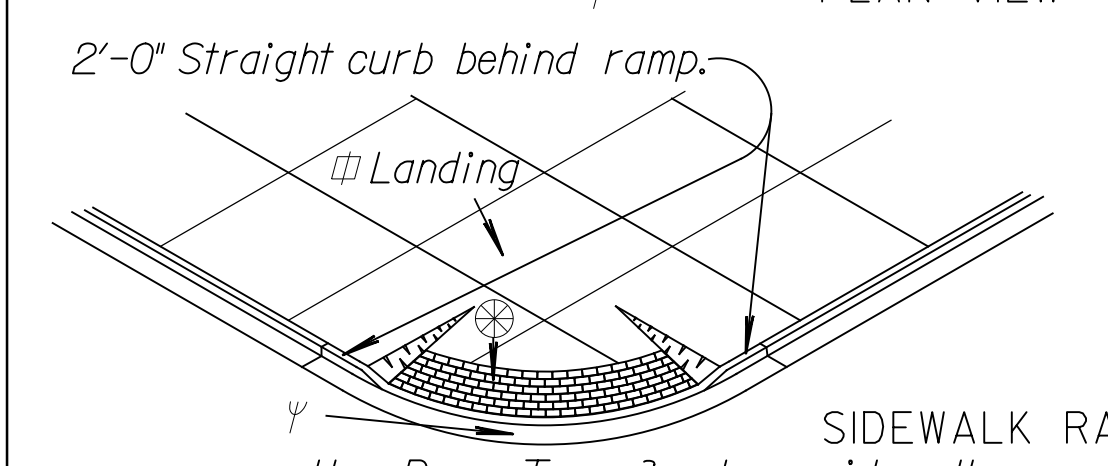
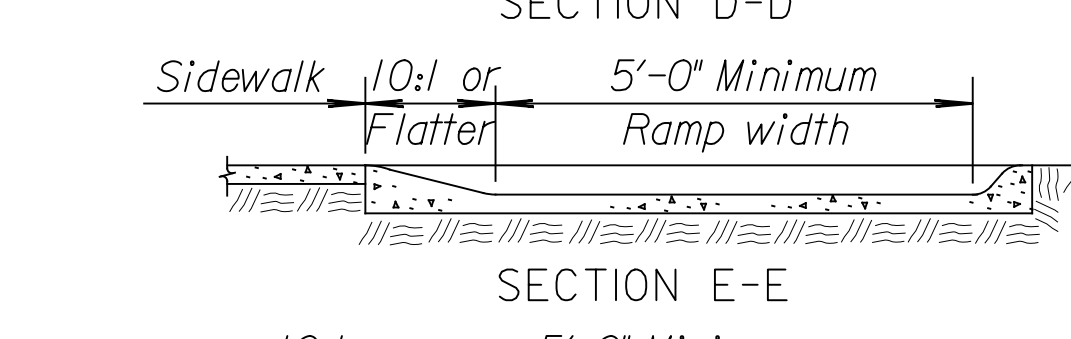
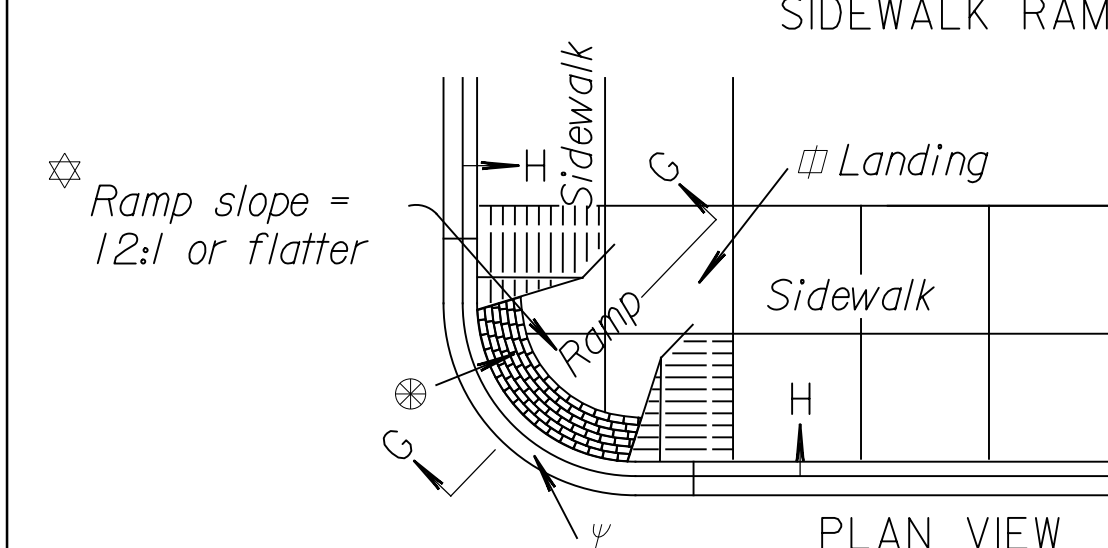
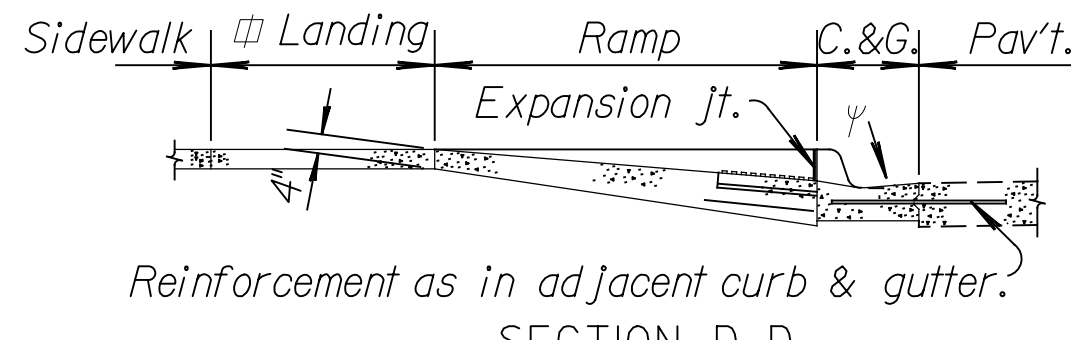
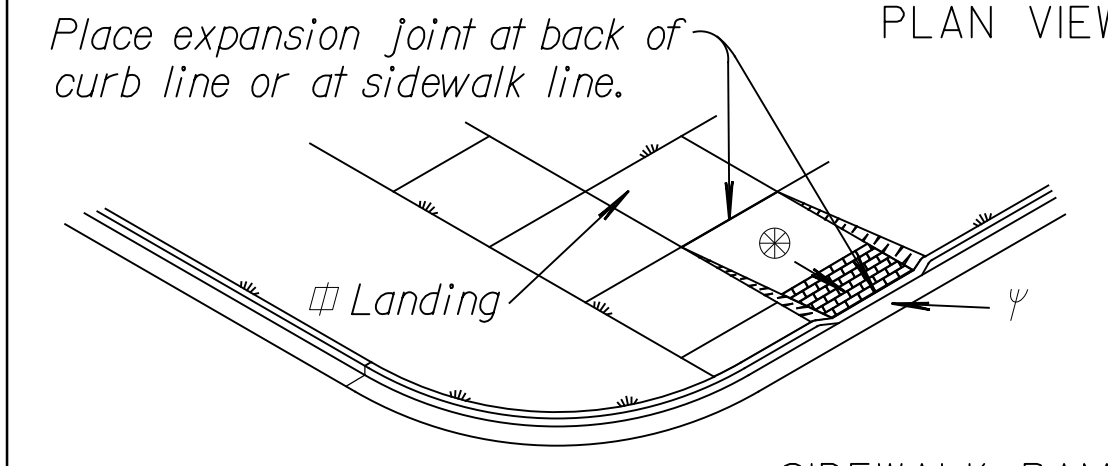
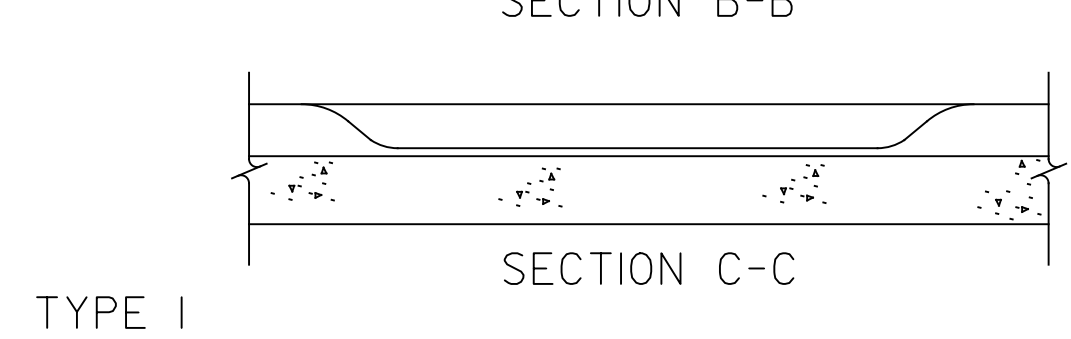
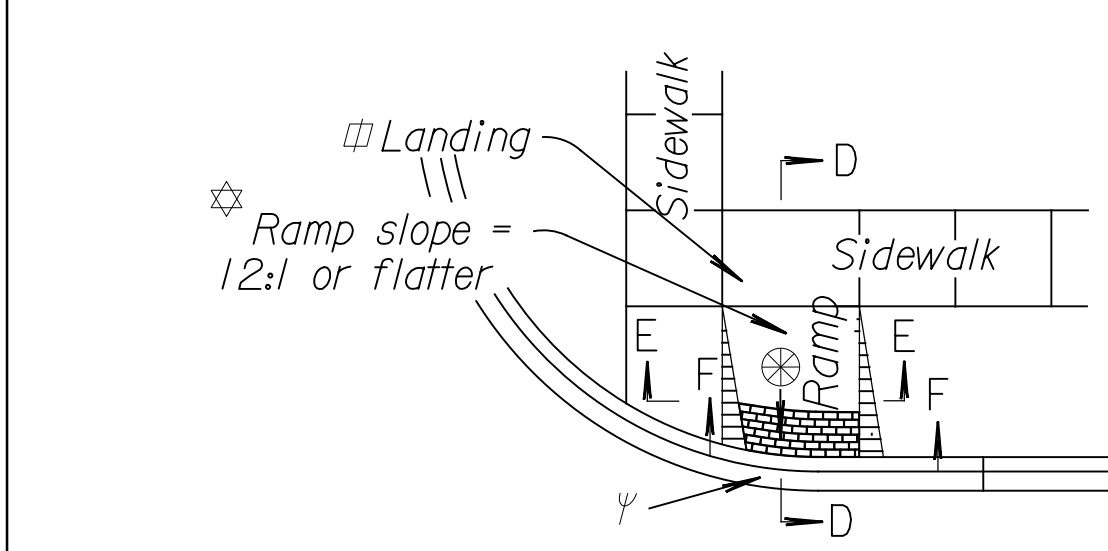
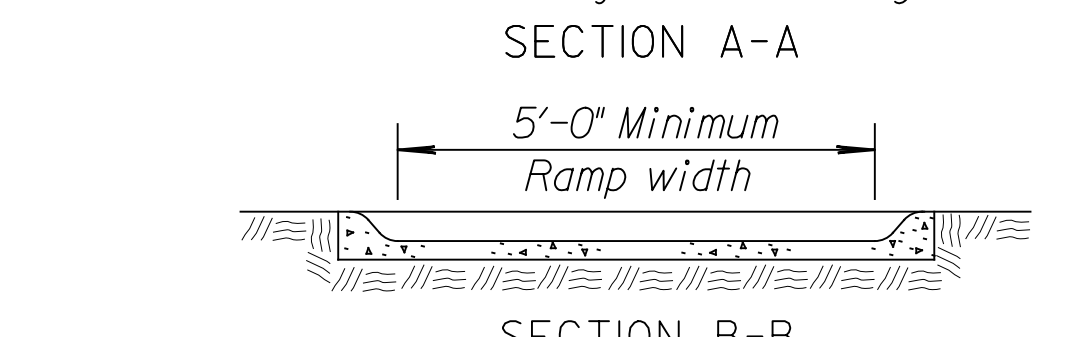
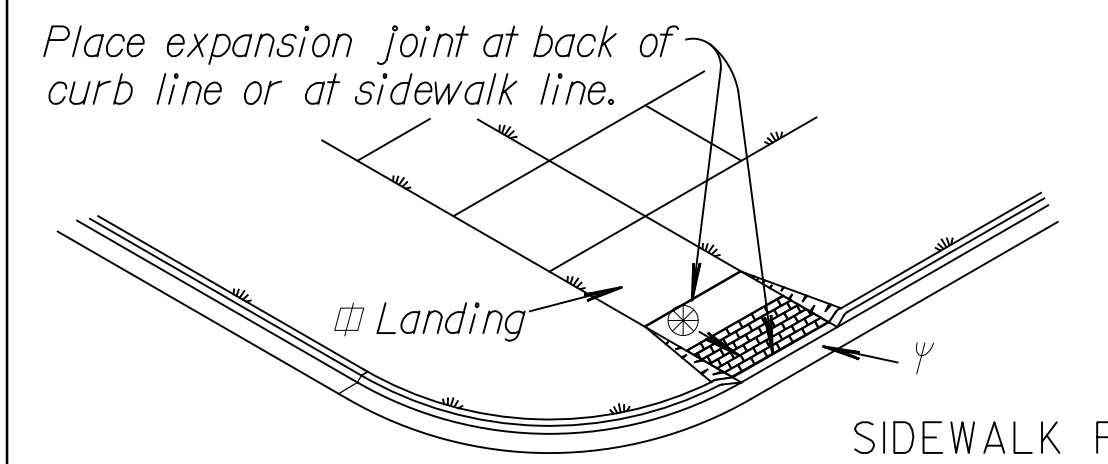
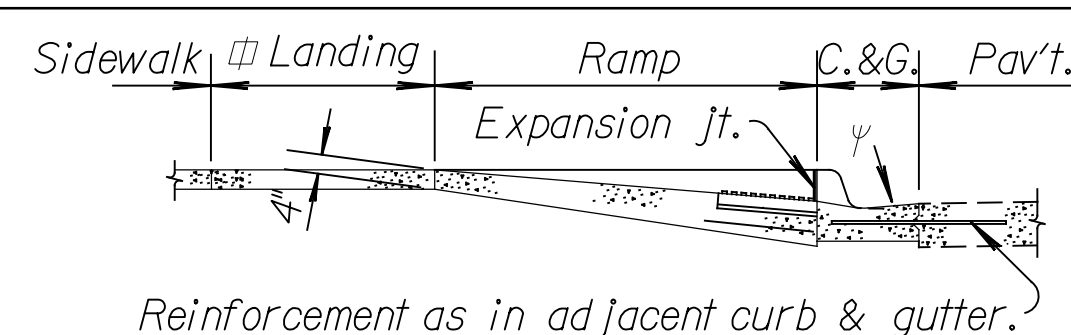
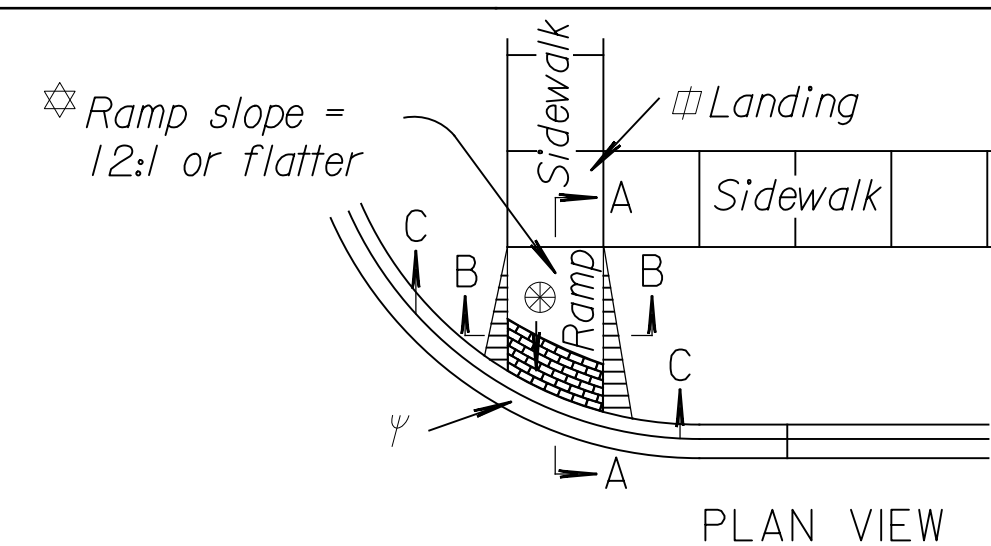
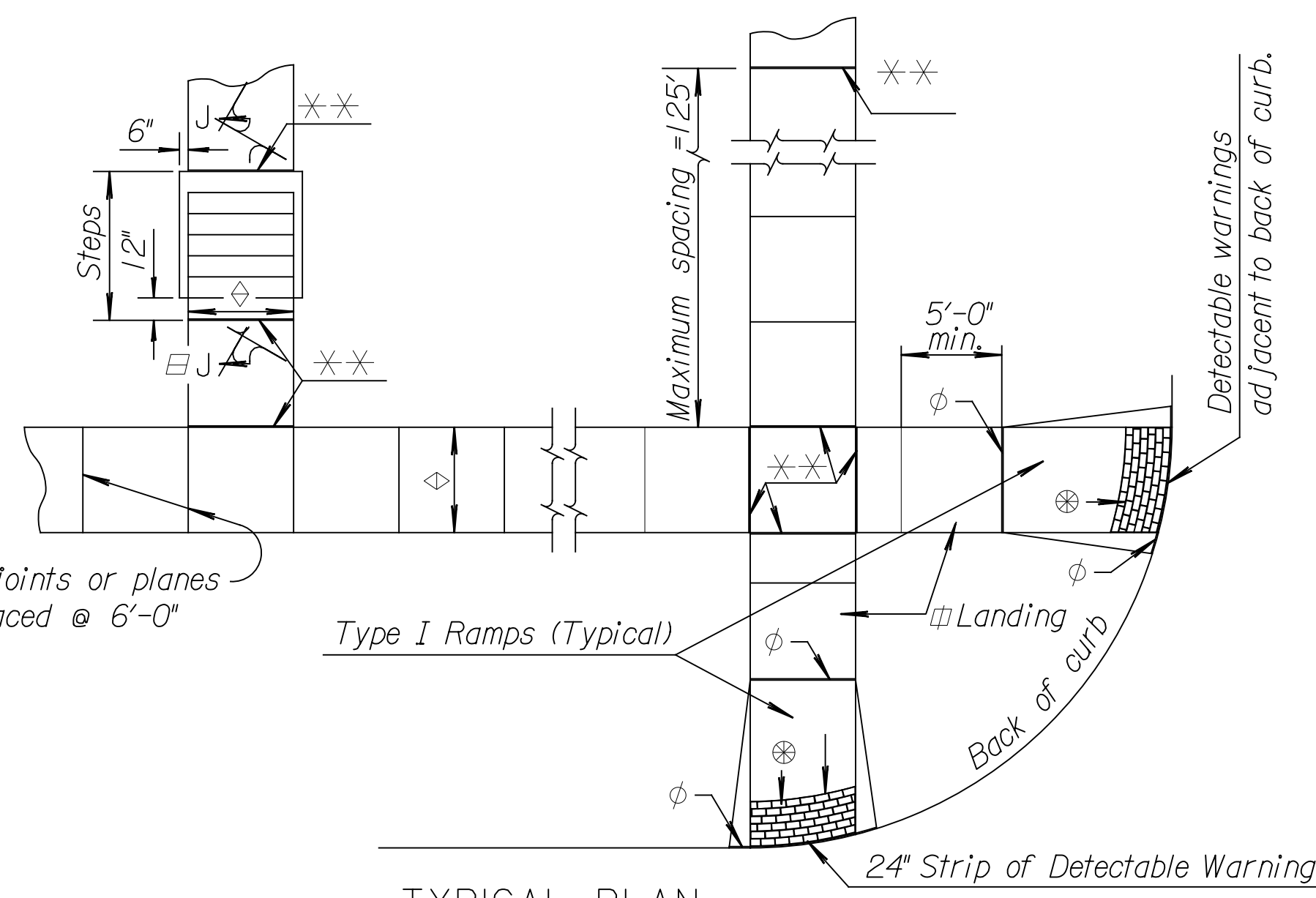

Construction joints or planes of weakness spaced @ 6'-0" ctrs. or less.

For other than 5'-0" (width) use 6" from the end and balanced (3'-0" max.) nail spacing.

Expansion Joint (3/4" Redwood board) placed at either back of curb line or at sidewalk back of curb line or at sidewalk line.

Expansion Joint (3/4" redwood board) located as shown.

Variable width (5'-0" min.). Entrance walk to be same width as approach walk. Use sidewalk width of 4'-0" where existing conditions prohibit use of 5'-0".

New construction ramp slopes are 12:1 or flatter. Desirable ramp slopes for existing sites are 12:1 or flatter. Where space limitations prohibit construction of a 12:1 slope on existing sites, use the following slopes:
 8:1 or flatter for a maximum rise of 3 inches
 10:1 or flatter for a maximum rise of 6 inches

Use a landing slope of 48:1 or flatter. Landings are the same width as ramp and a minimum 5'-0" in length.

Use a counter slope of 20:1 or flatter at the base of sidewalk ramps. Refer to standard drawing RD725A for additional curb and gutter details.

Detectable warning installation is typical and required on Sidewalk Ramps Type 1, Type 2, Type 3, median ramp crossings and other locations as shown in the plans. See standard drawing RD725A for additional details.

GENERAL NOTES
 The details depicted here may not be appropriate for all locations. Designs shall meet this criteria on all new construction projects unless impracticable by site restrictions. For an existing sidewalk facility where the sidewalk will be replaced, sidewalk will be replaced according to this drawing to the maximum extent feasible.
 Provided ramps at all corners of street intersections where there is existing or proposed sidewalk and curb. Provide ramps at mid-block walk locations for hospitals, medical centers and athletic stadiums.

Details shown on this sheet apply to all construction or reconstruction of streets, curbs or sidewalks. See standard specifications for additional information.
 Use of sidewalk ramp Type 2 shall be restricted to locations where is not feasible to use Types 1 or 3.
 Curb cut ramps are to be located as shown on the plans or as directed by the Engineer.

Drainage structures should not be placed in line with ramps except where existing drainage structures are being utilized in the new construction. Ramp location should take precedence over location of drainage structure.

Sidewalks shall be ramped where the driveway curb is extended across the walk. Construct ramp with uniform grade free of sags and short grade changes.

Place 3/4" redwood board expansion joints flush with the surface at a maximum spacing of 125'. Place 3/4" redwood expansion joints at sidewalk junctions, see Plan details. Where sidewalk abuts a curb place 3/4" redwood board expansion joint flush with the surface.

Place 1/2" preformed (Non-extruding, Type B) joint filler where sidewalk is parallel and adjacent to a rigid structure.

Slope sidewalk toward the street at a 50:1 or flatter. Slope or depress sidewalk where necessary to fit alleys and entrances see plans or at Engineer's direction.

Where clear width of sidewalk between top of ramp and building or other obstruction is less than 48 inches, slope the flared sides 12:1 or flatter.

Sidewalk shown to be constructed in back of an entrance is placed 6" thick with welded wire mesh reinforcement, gauge and spacing of wires is the same as in entrance pavement.

Use Concrete Grade 3.0 (AE) Contractor's option, throughout for construction of sidewalk and steps. All work and material required for installing sidewalk and steps is paid under the bid item "Concrete Sidewalk 4".

Surface texture ramp slope with a wooden float or brushed finish.

Plotted on: Monday October 24, 2011 09:33 AM
 mbechtel
 Plot Queue: \\ovpwp001\PLTWLP
 Pen Table: \\ovpwp001\Jobs\4809\Common\Highway\Library\lolo\pen\CC-23x36.pen
 Plot Scale: 1:000000.000000
 Design Filename: \\ovpwp001\Jobs\4809\Hoover\CD\Detail\KDOT\Nvr_r_d725.dgn

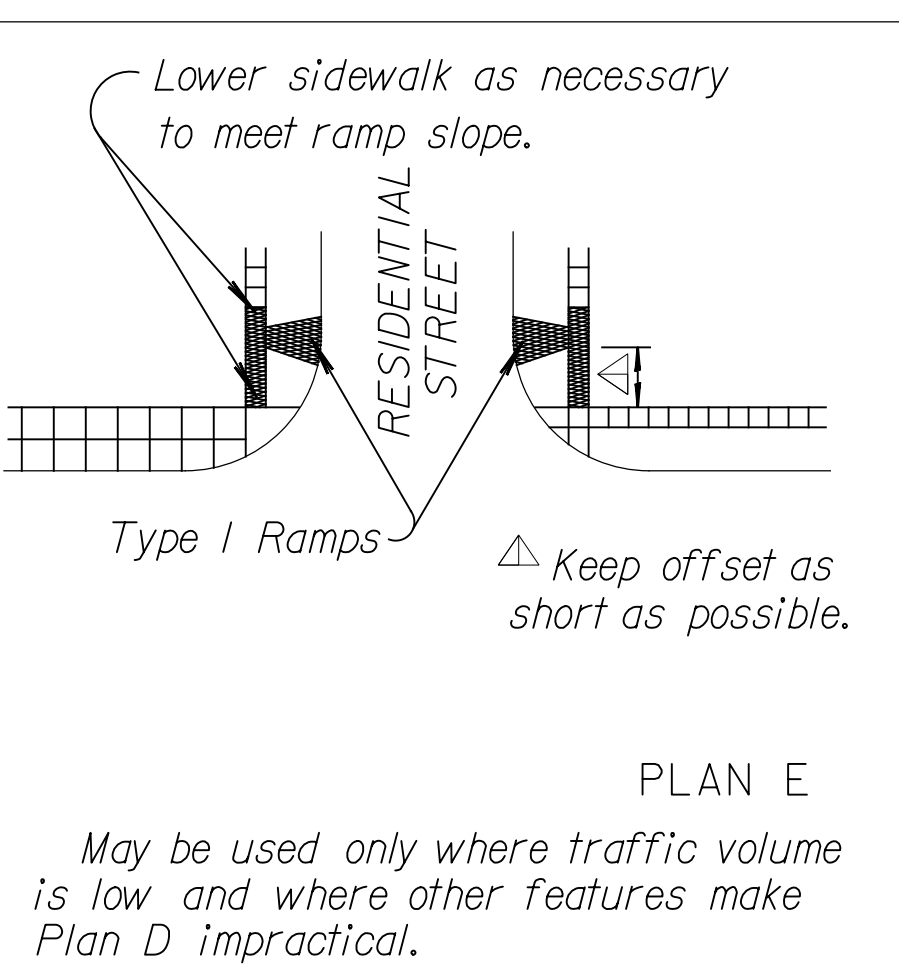
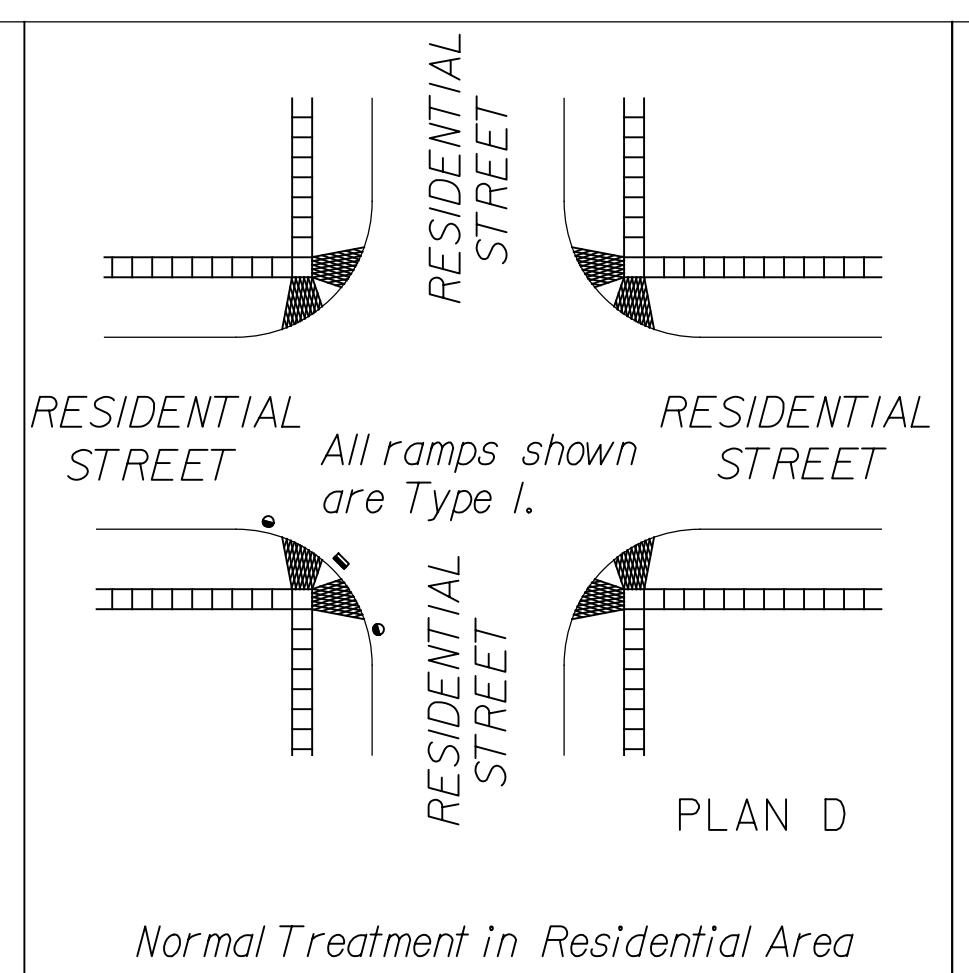
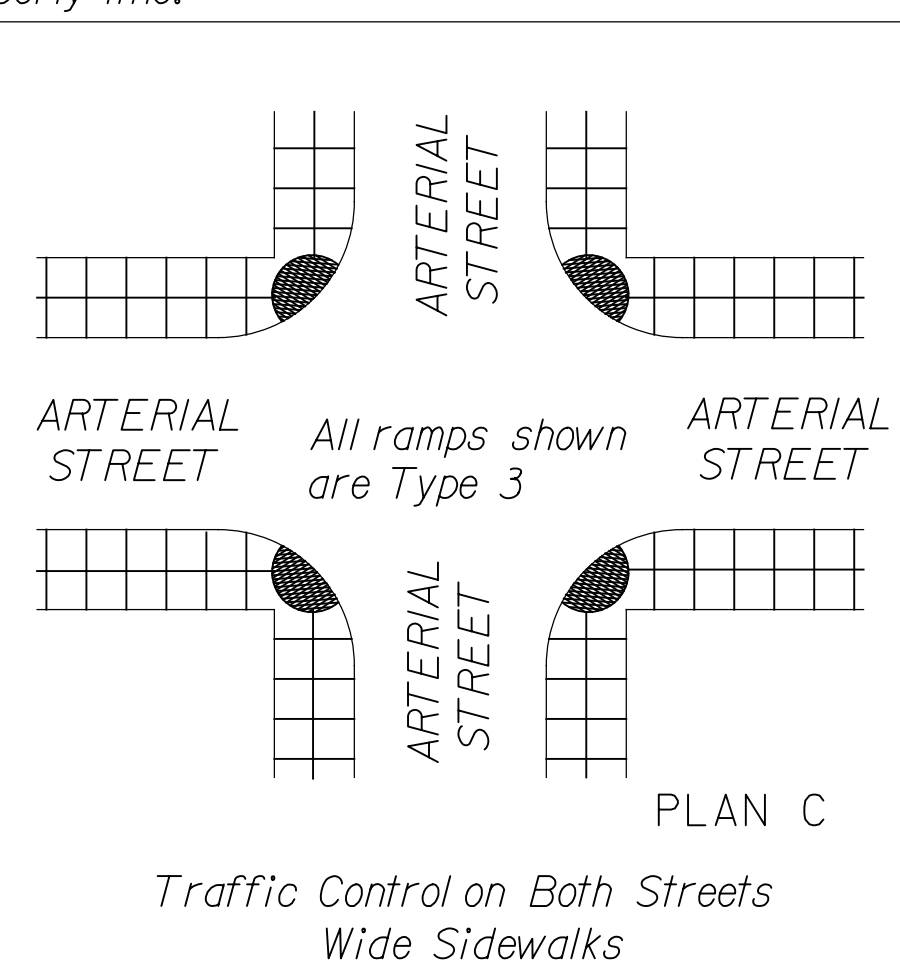
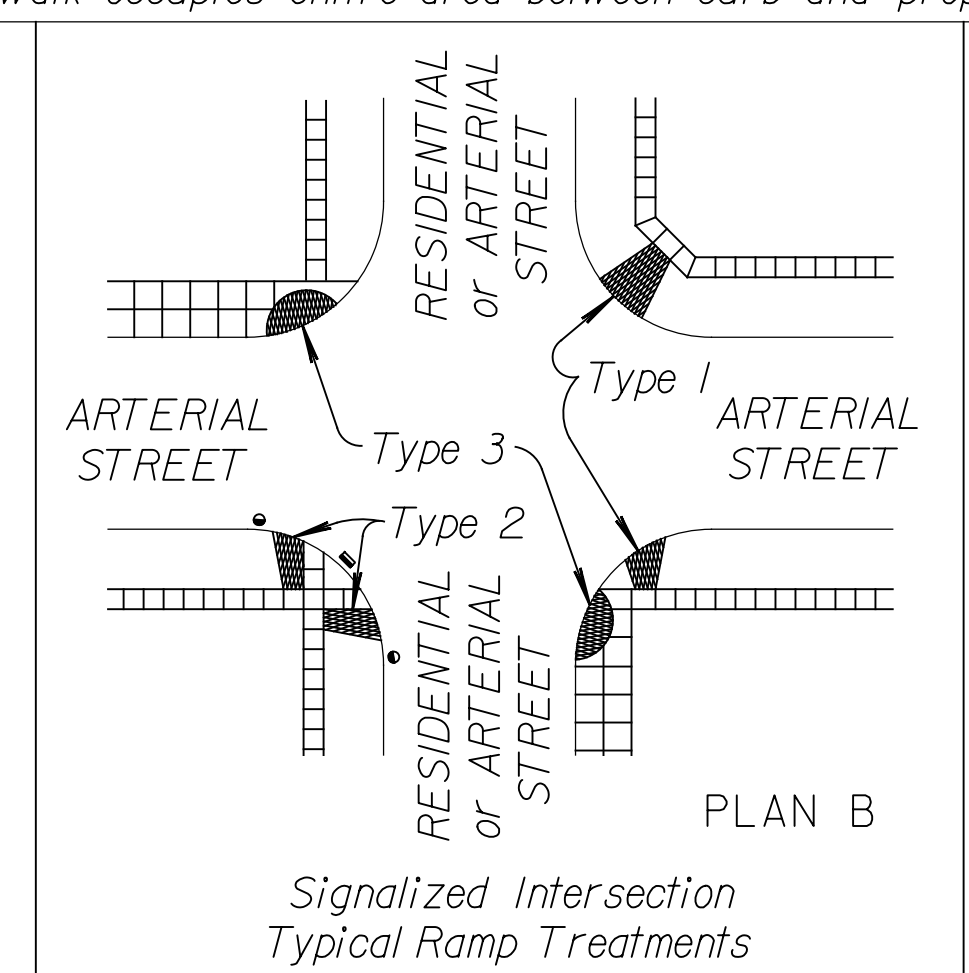
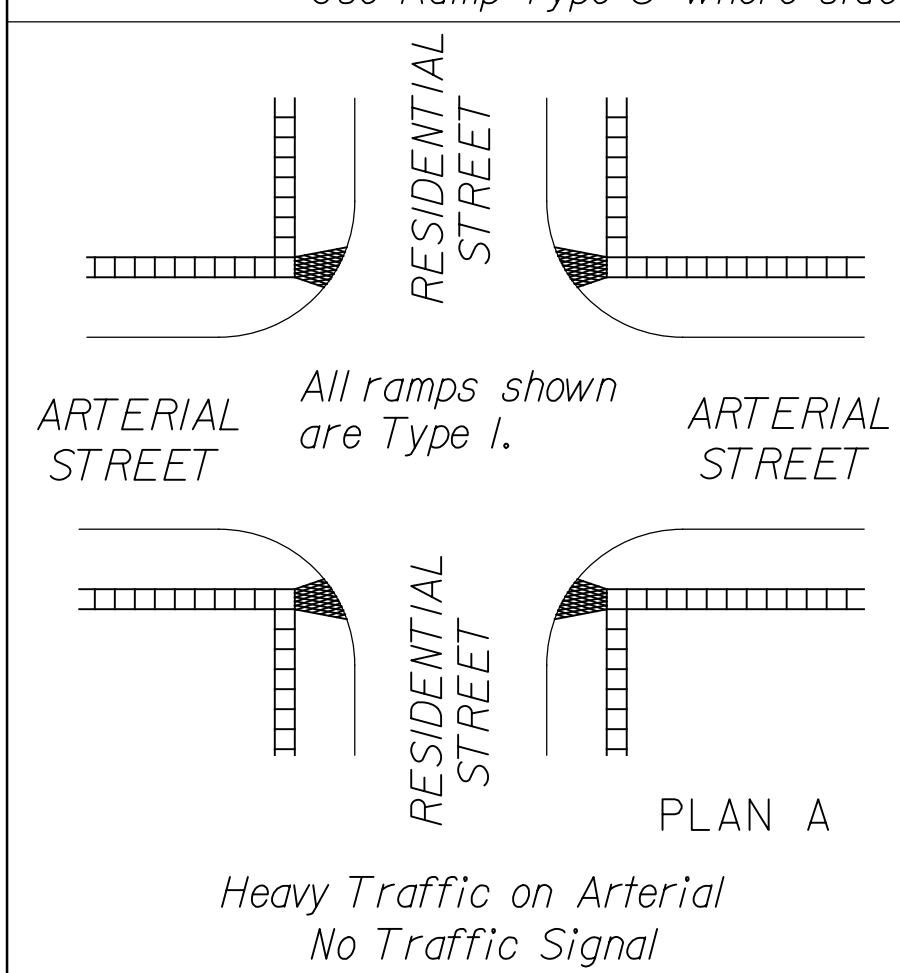

LEGEND

- Sidewalk Ramp Type 1
- Sidewalk Ramp Type 2
- Sidewalk Ramp Type 3
- Preferred location of drainage inlet (Typical)
- Alternate location of drainage inlet (Typical)
- Sidewalk

NO.	DATE	REVISIONS	BY	APP'D
9	2-10-10	Revised notes & General Note	S.W.K.	J.O.B.
8	7-30-08	Reorg. layout, added steps sheet	S.W.K.	J.O.B.
7	1-28-05	Changed Class to Grade concrete	S.W.K.	J.O.B.
6	8-20-03	Revised notes and details	S.W.K.	J.O.B.

KANSAS DEPARTMENT OF TRANSPORTATION

SIDEWALK & STEPS

RD725-

DESIGNED	4-7-10	APP'D	James O. Brewer
DETAIL CK.	DETAIL CK.	QUANTITIES	TRACED Bowser
DESIGN CK.	DESIGN CK.	QUAN. CK.	TRACE CK. King