

PRECAST MANHOLE LOCATED ALONG THE REINF. CONCRETE BOX SHALL HAVE A TONGUE & GROOVE JOINT AT THE MATING SURFACE OF THE BASE OF THE STACK & THE ADJOINING REINFORCED CONCRETE BOX.

PRECAST MANHOLE DETAIL

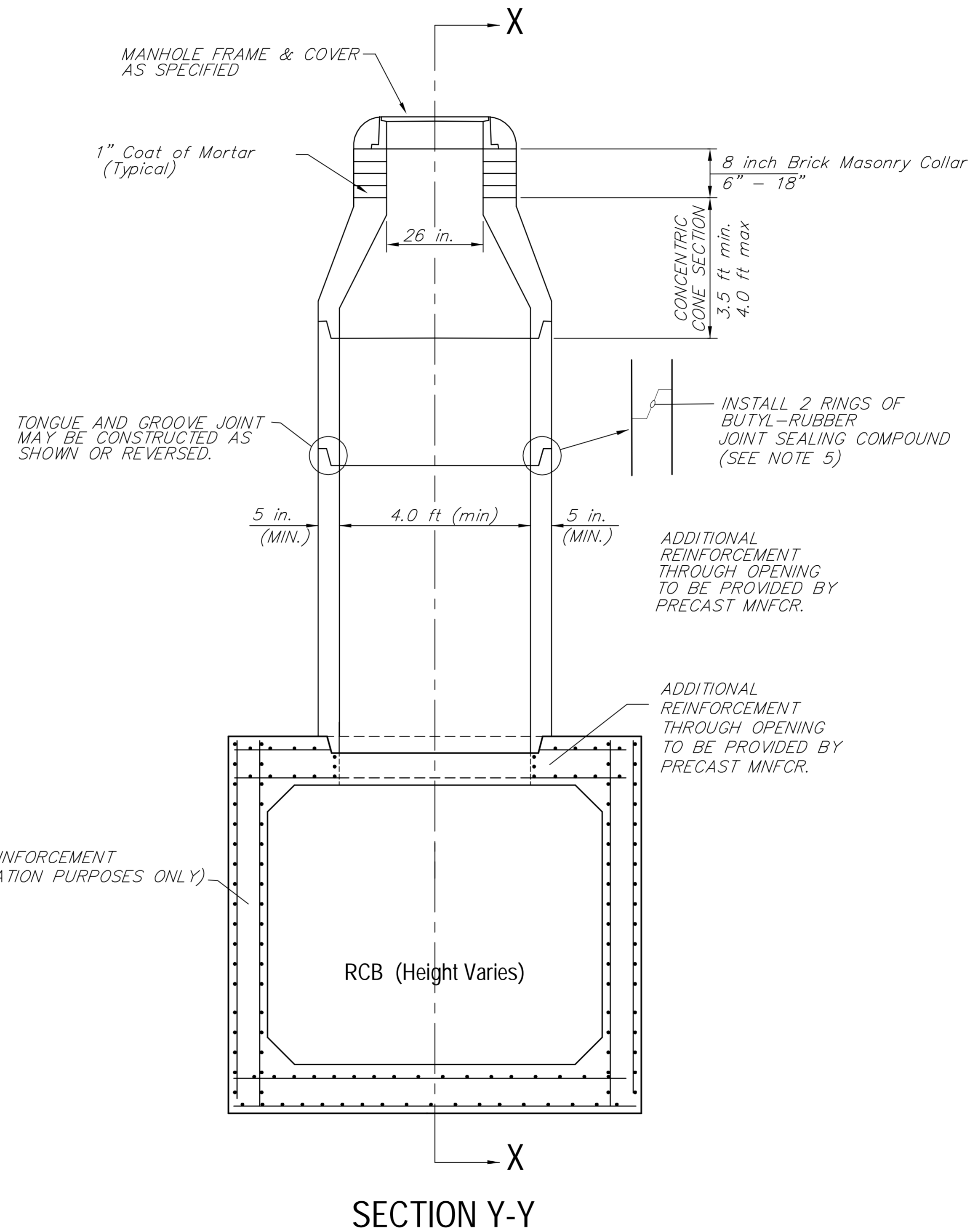
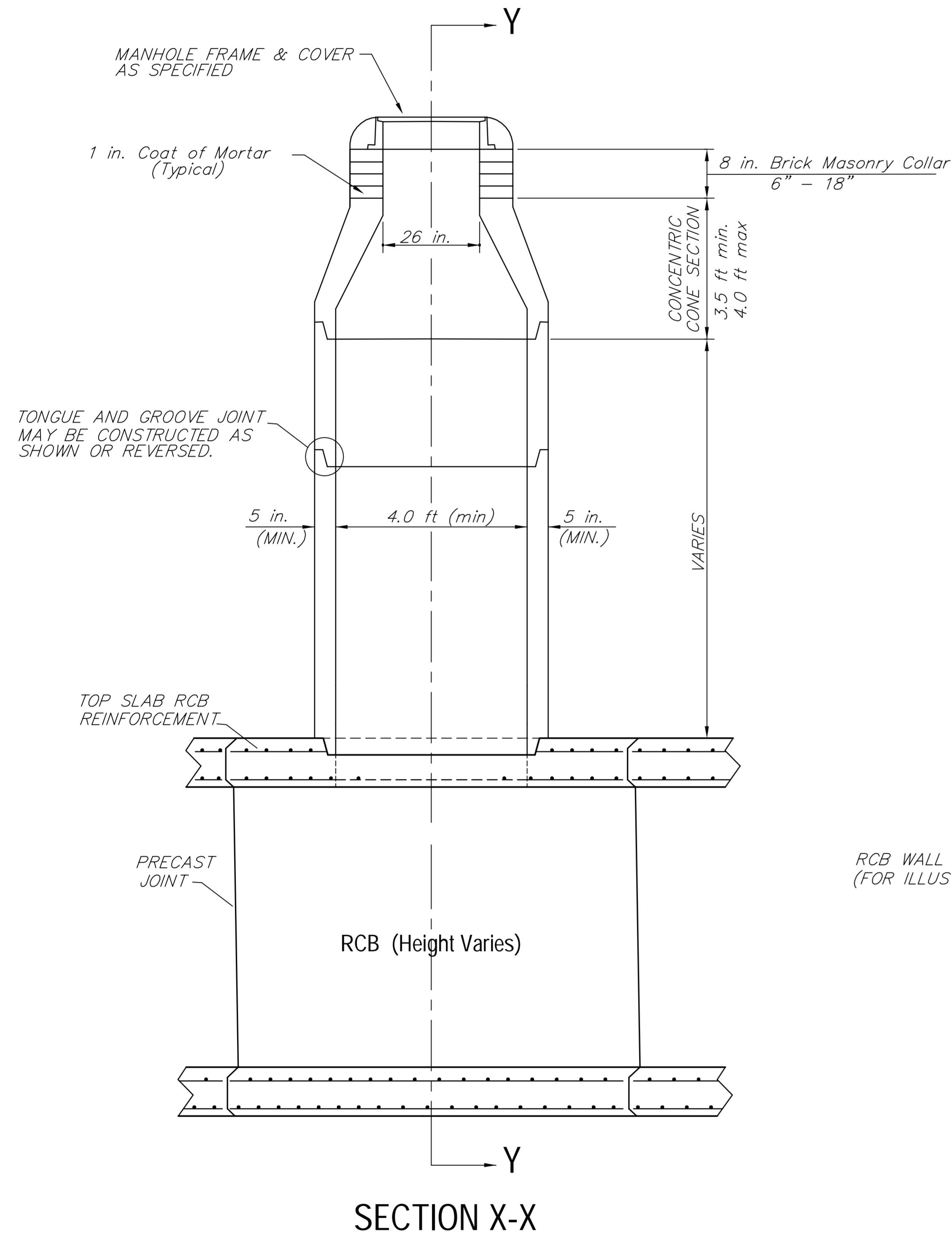

GENERAL NOTES

- ALL PRECAST CONCRETE MANHOLE SECTIONS SHALL CONFORM TO THE LATEST REVISIONS OF A.S.T.M. C-478M AS MODIFIED BY THE SPECIFICATIONS.
- NON-SHRINK GROUT SHALL BE NON-METALLIC TYPE.
- EXTERIOR MANHOLE WALLS SHALL BE COATED WITH 1 COAT MOBILARMA 633 BITUMINOUS COATING OR APPROVED EQUAL.
- JOINT SEALING COMPOUND SHALL BE KENT SEAL NO. 2 OR APPROVED EQUAL.
- LIFTING HOLES SHALL BE FILLED WITH NON-SHRINK GROUT AND THE INTERIOR SURFACE COATED AS SPECIFIED.
- MORTAR USED IN MASONRY CONSTRUCTION SHALL CONTAIN 8.0 SACKS OF CEMENT PER ONE CUBIC YARD.
- MANHOLES CONSTRUCTED WHERE INFLOWING PIPE SIZES ARE SMALLER THAN 24 in. SHALL HAVE AN INSIDE DIAMETER OF 4.0 Ft. MANHOLES CONSTRUCTED WHERE PIPE SIZES ARE 24 in. OR LARGER SHALL HAVE AN INSIDE DIAMETER OF 5.0 Ft. COMPLETED MANHOLE SHALL BE WITHOUT LEAKS AND WATER TIGHT.
- MANHOLE COVER CASTINGS AND MANHOLE FRAME CASTINGS SHALL CONFORM TO THE REQUIREMENTS AS INDICATED IN THE STANDARD SPECIFICATIONS AND AS SHOWN IN THE STANDARD DETAIL DRAWING.
- THE BID ITEM "PRECAST ACCESS MANHOLE" SHALL INCLUDE ALL MATERIAL, PAINTING, CAST IRON, EXCAVATION, BACKFILLING, EQUIPMENT, TOOLS, AND ALL OTHER INCIDENTALS NECESSARY TO COMPLETE THE WORK.
- A BRICK MASONRY COLLAR SHALL BE INSTALLED BETWEEN THE CAST IRON FRAME AND THE CONCENTRIC CONE. THE COLLAR WILL HAVE 8 INCH WALLS AND A VERTICAL HEIGHT OF 6 in. MINIMUM AND 18 in. MAXIMUM. A 1 in. COAT OF MORTAR WILL BE PLASTERED ON THE OUTSIDE OF THE COLLAR. THE USE OF PRE-CAST CONCRETE SPACERS FOR MANHOLE TOP ADJUSTMENT SHALL BE ALLOWED.
- PIPES INSTALLED WITHIN THE EXCAVATION MADE FOR THE MANHOLE MAY REQUIRE (WHEN DIRECTED BY THE ENGINEER) A SUPPORTING CONCRETE CRADLE TO THE LIMITS OF THE EXCAVATION. COST OF CRADLE WITHIN MANHOLE EXCAVATION SHALL BE INCLUDED IN THE UNIT PRICE BID FOR THE MANHOLE.

Drawing File: E:\Project\Meridian Drainage\Details\Access MH.dwg

Design: City of Wichita
Drawn: STAFF
Approved: TPV
Scale: None

Project No. 0802E038 CAPITAL IMPROVEMENT PROJECT
STANDARD DETAILS for
PRECAST ACCESS MANHOLES
MERIDIAN AVENUE DRAINAGE OUTFALL PROJECT

Baughman Company, P.A.
315 Ellis St., Wichita, KS 67211 P 316-262-7271 F 316-262-0149
ENGINEERING | SURVEYING | PLANNING | LANDSCAPE ARCHITECTURE

January 2013
SHEET
92
OF
118