

STA. 220+25 LT.

RIPRAP LAYOUT			
LOCATION	STATION	OFFSET	ELEVATION
1	219+47.39	62.25' Lt.	1338.81
2	219+49.40	56.56' Lt.	1337.81
3	219+50.60	53.14' Lt.	1337.81
4	219+52.61	47.44' Lt.	1338.81
5	219+97.45	71.25' Lt.	1334.74
6	220+06.15	64.67' Lt.	1334.40
7	220+14.45	63.60' Lt.	1332.40
8	220+00.61	77.29' Lt.	1333.46
9	219+98.64	80.34' Lt.	1333.46
10	219+90.42	83.03' Lt.	1334.13
11	219+95.78	88.12' Lt.	1333.81
12	220+12.18	82.75' Lt.	1332.40
13	220+35.70	82.75' Lt.	1332.40
14	220+40.57	86.36' Lt.	1332.79
15	219+99.60	91.77' Lt.	1335.71
16	220+43.16	91.77' Lt.	1335.48
17	220+53.30	112.91' Lt.	1340.01
18	220+54.60	115.62' Lt.	1340.09
19	220+58.21	113.89' Lt.	1336.25
20	220+61.82	112.16' Lt.	1336.25
21	220+65.42	110.43' Lt.	1339.85
22	220+56.91	111.18' Lt.	1336.25
23	220+60.52	109.45' Lt.	1336.25
24	220+64.12	107.72' Lt.	1339.72
25	220+47.52	91.61' Lt.	1333.99
26	220+51.13	89.88' Lt.	1333.99
27	220+53.98	86.58' Lt.	1334.82
28	220+51.39	81.17' Lt.	1333.82
29	220+49.83	77.91' Lt.	1333.82
30	220+35.70	63.60' Lt.	1332.40
31	220+44.01	64.67' Lt.	1334.40
32	220+53.24	71.77' Lt.	1335.18
33	220+97.40	48.44' Lt.	1340.30
34	220+99.40	54.13' Lt.	1339.30
35	221+00.60	57.56' Lt.	1339.30
36	221+02.60	63.26' Lt.	1340.30

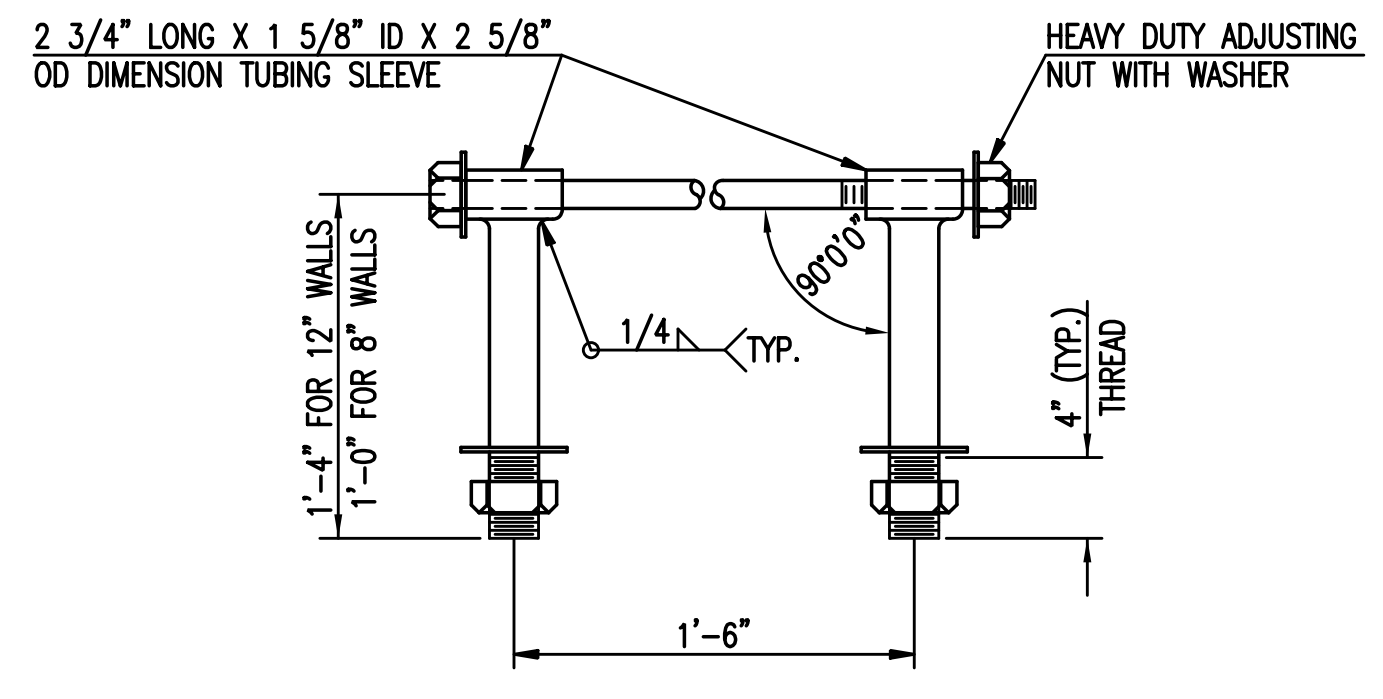

HEAVY DUTY (H.D.) COUPLER
NO SCALE

- NOTES
- BOLTS TO BE A-36 1 1/2" DIAMETER.
 - BOLTS, NUTS, WASHERS AND SLEEVES TO BE ZINC PLATED.
 - WASHERS TO BE 3 1/2" O.D. X 7 GAUGE.
 - SHIP WITH NUTS AND WASHERS PLACED ON BOLTS.

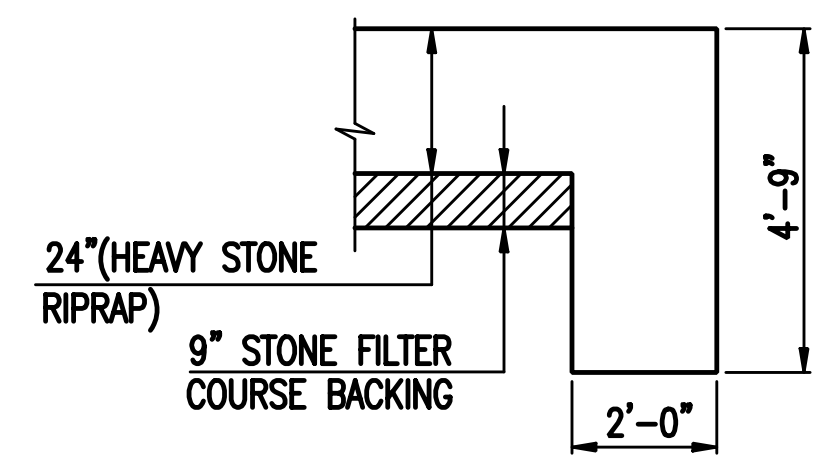

TYPICAL SECTION THRU TOEWALL
NO SCALE

- NOTES
- ALL RIPRAP FOR THIS PROJECT SHALL BE NATURAL STONE. NEITHER BROKEN CONCRETE, FABRIC ENVELOPE, NOR PREMIXED DRY PACKAGED CONCRETE BAG ALTERNATES WILL BE ALLOWED, UNLESS INDICATED OTHERWISE.
 - TOEWALLS SHALL BE INSTALLED ALONG ALL UNPROTECTED EDGES OF STONE RIPRAP.
 - GROUTING OF THE SURFACE OF THE RIPRAP SHALL NOT BE PERFORMED, UNLESS INDICATED OTHERWISE. GROUTING OF THE TOEWALLS SHALL BE PERFORMED PER CITY SPECIFICATIONS.

HEAVY STONE RIPRAP DETAILS

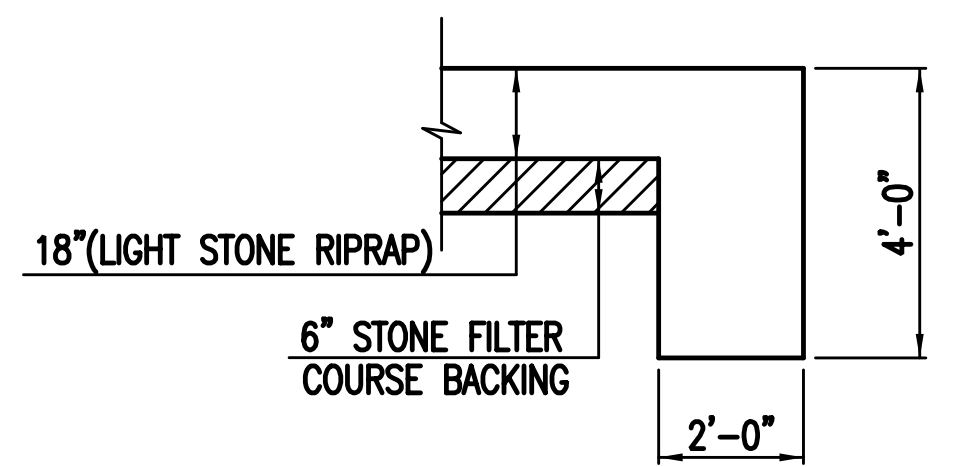

TYPICAL SECTION THRU TOEWALL
NO SCALE

- NOTES
- ALL RIPRAP FOR THIS PROJECT SHALL BE NATURAL STONE. NEITHER BROKEN CONCRETE, FABRIC ENVELOPE, NOR PREMIXED DRY PACKAGED CONCRETE BAG ALTERNATES WILL BE ALLOWED, UNLESS INDICATED OTHERWISE.
 - TOEWALLS SHALL BE INSTALLED ALONG ALL UNPROTECTED EDGES OF STONE RIPRAP.
 - GROUTING OF THE SURFACE OF THE RIPRAP SHALL NOT BE PERFORMED, UNLESS INDICATED OTHERWISE. GROUTING OF THE TOEWALLS SHALL BE PERFORMED PER CITY SPECIFICATIONS.

LIGHT STONE RIPRAP DETAILS

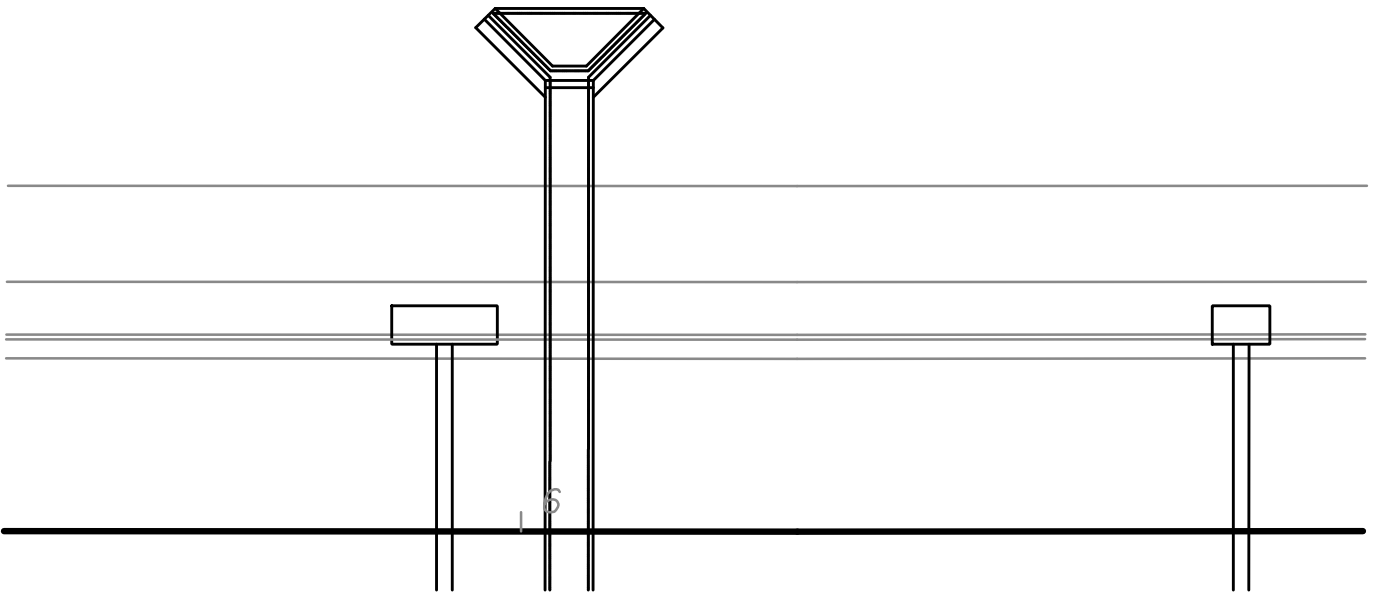
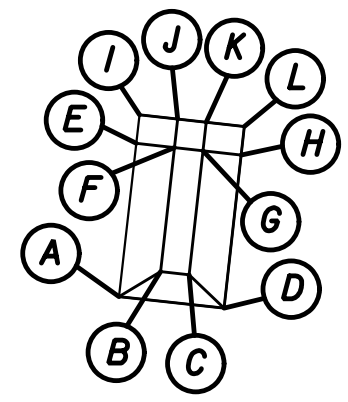

STA. 226+05 LT.

RIPRAP LAYOUT			
LOCATION	STATION	OFFSET	ELEVATION
A	226+44.52	66.26' Lt.	1341.78
B	226+48.84	68.86' Lt.	1341.94
C	226+51.82	68.52' Lt.	1342.05
D	226+55.45	65.05' Lt.	1342.18
E	226+46.32	82.22' Lt.	1445.09
F	226+50.30	81.77' Lt.	1344.47
G	226+53.28	81.44' Lt.	1344.47
H	226+57.25	80.99' Lt.	1345.11
I	226+46.66	85.20' Lt.	1345.34
J	226+50.63	84.75' Lt.	1344.47
K	226+53.61	84.42' Lt.	1344.47
L	226+57.59	83.97' Lt.	1345.30

Checked: 10/22/2010, 6:50:58 PM by: PEF
 Plot: 11/16/10, 11:16:44 AM by: PEF
 File: \\2010\10281\Standards\0281-SW-401-Miscellaneous Details



**MISCELLANEOUS
DETAILS
(STORM SEWER)**

CITY ENGINEER
GARY JANZEN, P.E.

PROJECT NUMBER 472-84915	OCA NUMBER 707022	DATE 11/2010
-----------------------------	----------------------	-----------------

CITY ENGINEER'S OFFICE
CITY HALL - SEVENTH FLOOR
455 NORTH MAIN STREET
WICHITA, KANSAS 67202-1620
(316) 268-4501

DESIGN	DRAWN
SHEET 22 of 83	