

# TYPICAL 35' B-B PAVEMENT DETAILS

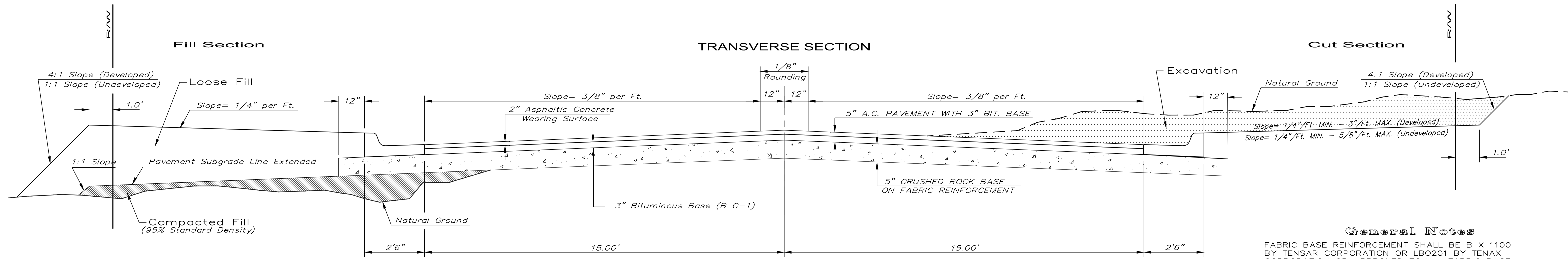

### CRUSHED ROCK GRADATION REQUIREMENTS

PERCENT OF AGGREGATE RETAINED

2-1/2"	0
3/4"	20 - 60
#4	50 - 80
#40	80 - 94
#200	90 - 98

ROCK QUALITY SHALL CONFORM TO THE REQUIREMENTS SPECIFIED BY THE KDOT 1990 EDITION STANDARD SPECIFICATION SUBSECTION 1102 FOR DURABILITY CLASS I.



	DISTANCE FROM CENTERLINE (LT. & RT.)											
	0'	2'	4'	6'	8.5'	10'	12'	14'	15'	17'	17.5'	18.5'
A: Top of Curbs to Top of Surface Lift	0.04	0.08	0.14	0.21	0.29	0.33	0.39	0.46	0.49	-	-	-
B: Top of Curbs to Top of Upper Base Lift	0.21	0.25	0.31	0.37	0.45	0.50	0.56	0.62	0.65	-	-	-
C: Top of Curbs to Top of C. R. Subgrade	0.46	0.50	0.56	0.63	0.71	0.75	0.81	0.88	0.91	0.97	0.98	1.01

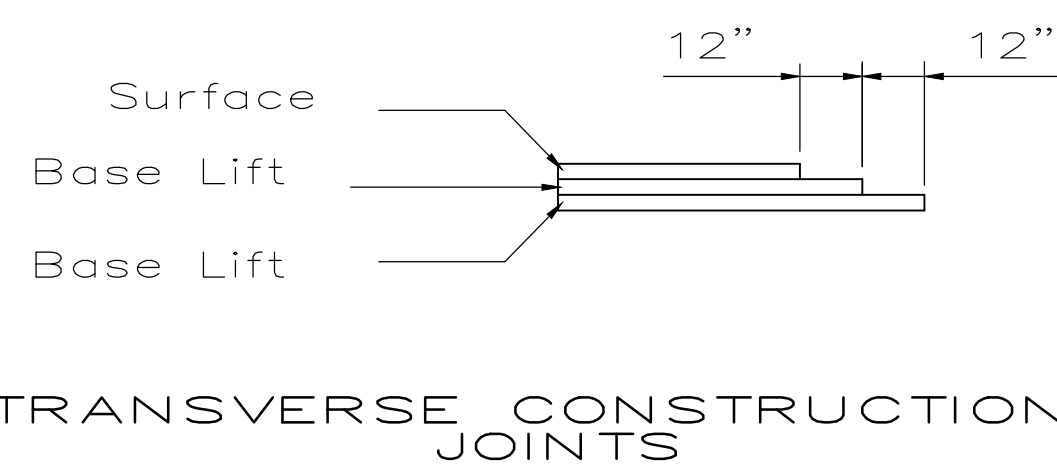

Transverse construction joints shall be constructed in flexible base pavements at locations where pavement joins existing flexible base pavement as shown by the detail. All costs associated with the construction of the transverse joint shall be included in the bid price for Square Yards 5" ASPHALTIC CONCRETE (3" BITUMINOUS BASE).

- ### General Notes
- FABRIC BASE REINFORCEMENT SHALL BE B X 1100 BY TENSAR CORPORATION OR LBO201 BY TENAX CORPORATION OR APPROVED EQUAL. FABRIC BASE REINFORCEMENT SHALL BE INSTALLED IN ACCORDANCE WITH MANUFACTURER'S RECOMMENDATIONS.
  - ROCK BASE IS TO BE COMPACTED AND SMOOTHED WITH A STEEL FACED ROLLER PRIOR TO PLACEMENT OF ASPHALT. TACK COAT WILL NOT BE APPLIED TO ROCK BASE.
  - A TACK COAT OF EMULSIFIED ASPHALT (SC-1H OR CSS-1H) SHALL BE APPLIED AT AN APPROXIMATE RATE OF 0.05 GALLONS PER SQUARE YARD BETWEEN EACH LIFT OF ASPHALTIC MATERIAL.
  - BITUMINOUS BASE AND ASPHALTIC CONCRETE WEARING SURFACE SHALL BE PLACED WITH A LAYDOWN MACHINE HAVING AUTOMATIC CONTROLS FOR LINE AND GRADE.
  - CONSTRUCTION JOINTS IN EACH LIFT SHALL BE STAGGERED A MINIMUM DISTANCE OF ONE (1) FOOT FROM JOINTS IN PRECEDING LIFTS AND PLACED SO THAT A JOINT WILL BE CONSTRUCTED ON THE CENTERLINE OF THE TOP LIFT.
  - THE ASPHALTIC CONCRETE PAVEMENT BETWEEN THE COMBINED CURB AND GUTTER SHALL BE PAID AS SQUARE YARDS OF 5" ASPHALTIC CONCRETE (3" BITUMINOUS BASE).

	5 Inch Residential Asphaltic Concrete Pavement w/Crushed Rock Base on Fabric Reinf. City of Wichita, Kansas	
	Baughman Company, P.A. 315 Ellis St., Wichita, KS 67211 P 316-263-2771 F 316-262-0149 ENGINEERING   SURVEYING   PLANNING   LANDSCAPE ARCHITECTURE	
PROJECT NUMBER	DESIGN C.O.W.	DRAWN Staff
REVISIONS:	APPROVED	DATE 08/13
	SCALE None	SHEET
		2 OF 31