

COMBINED CURB & GUTTER (6")

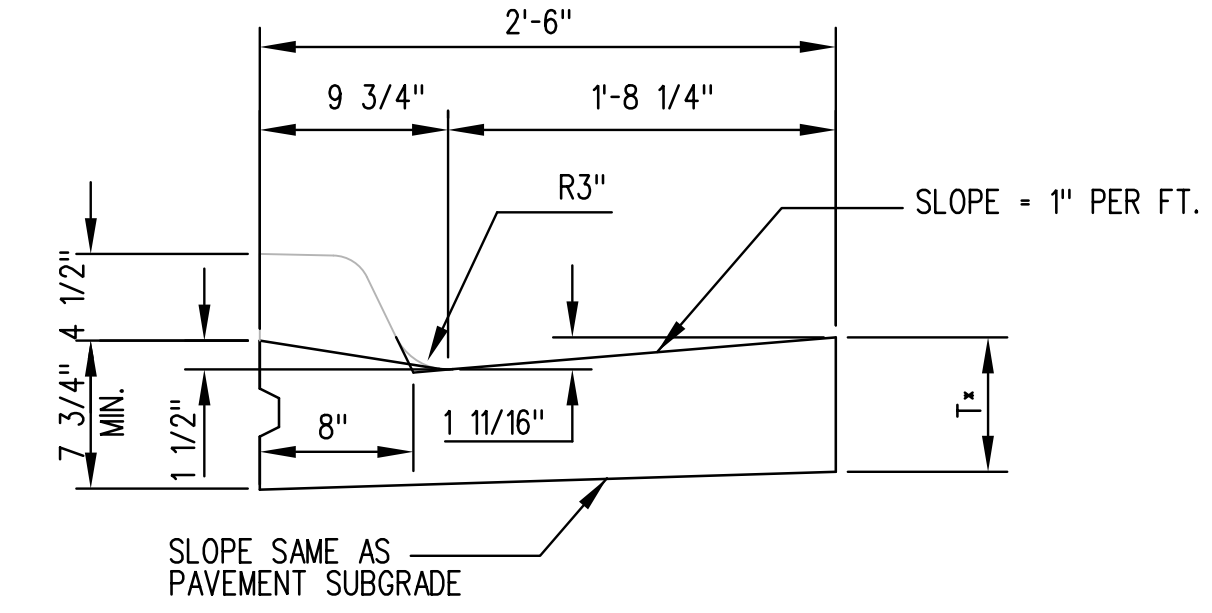

COMBINED CURB & GUTTER (1 1/2")

When plans indicate curb type to be "Special", the curb gutter pan shall be sloped the same as adjacent pavement.

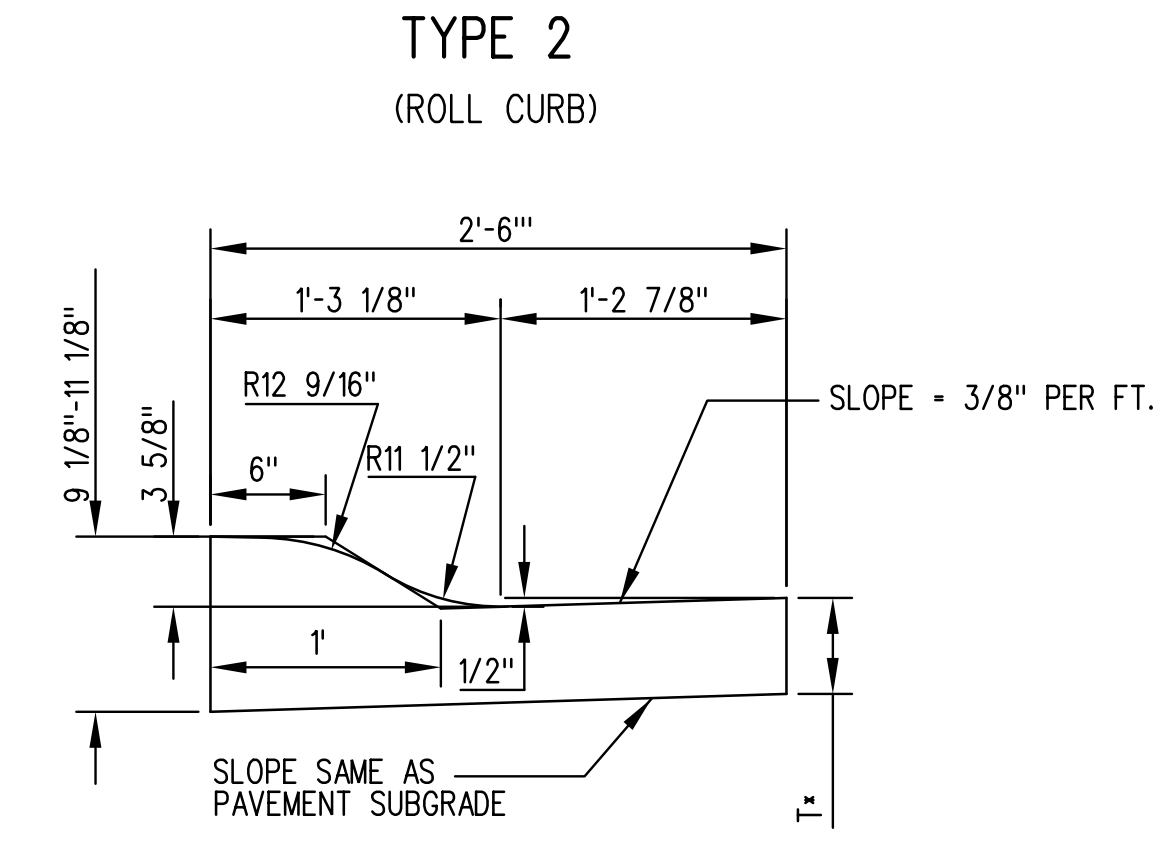

COMBINED CURB & GUTTER (3 5/8")

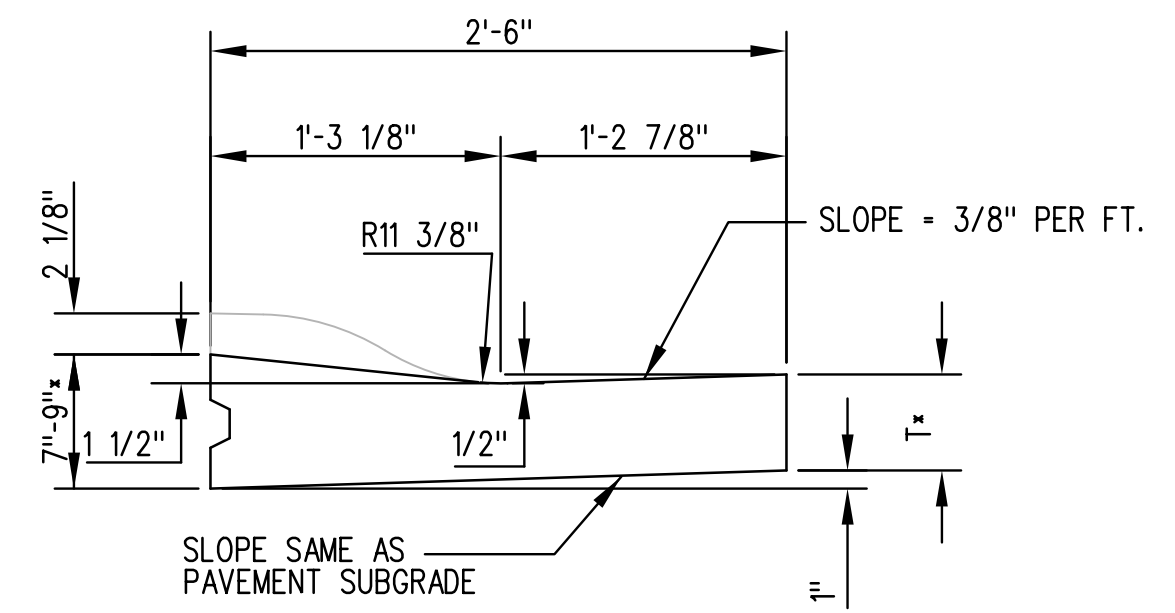

COMBINED CURB & GUTTER (1 1/2")

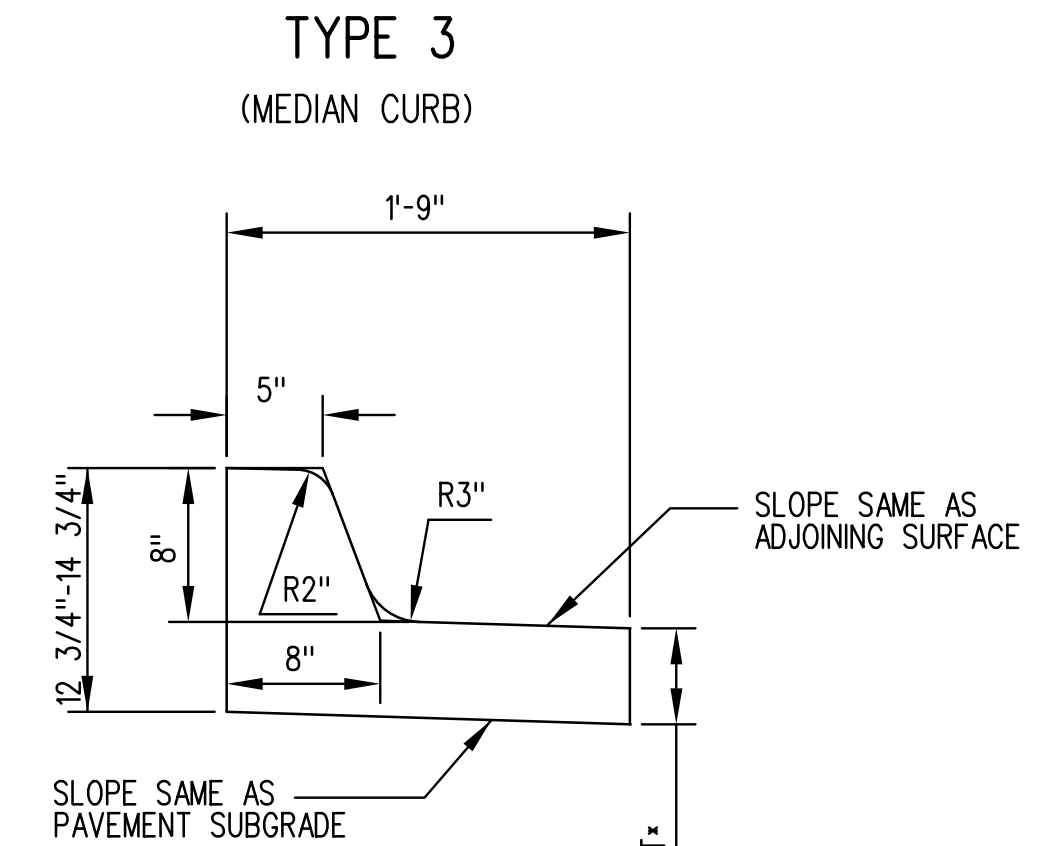

COMBINED CURB & GUTTER (8")

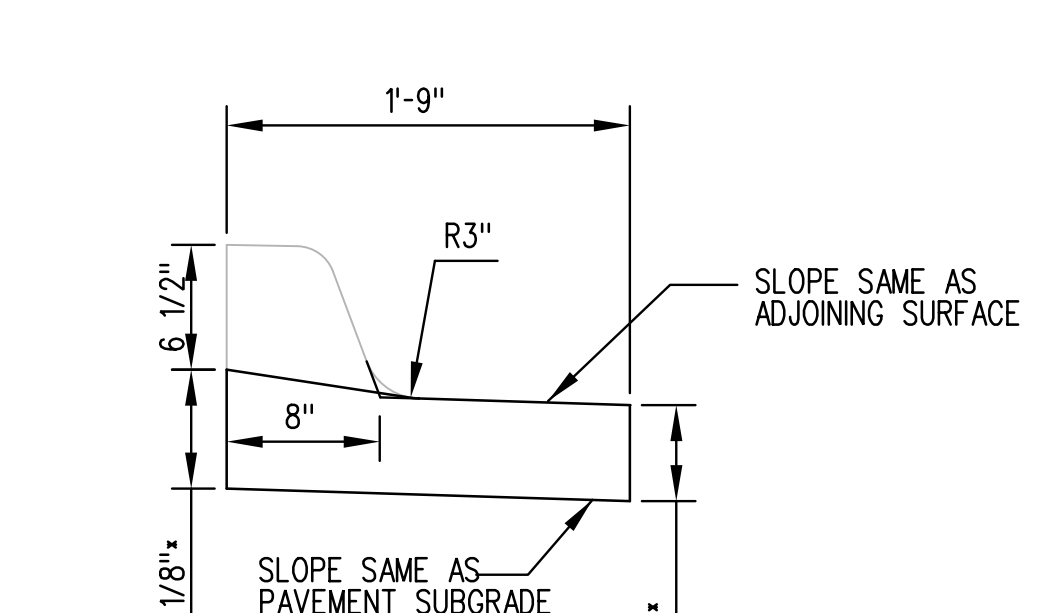

COMBINED CURB & GUTTER (1 1/2")

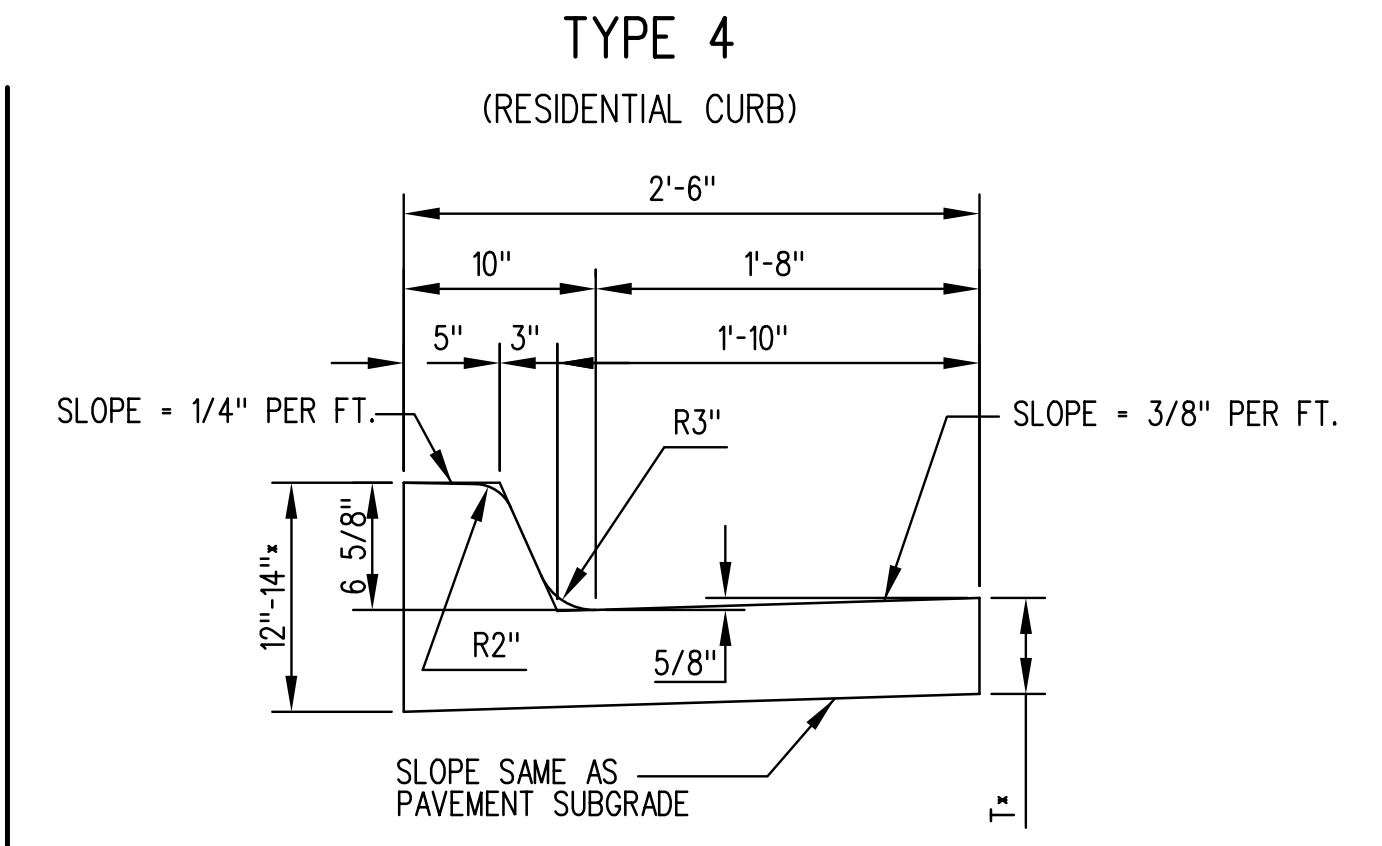

COMBINED CURB & GUTTER (6 5/8")

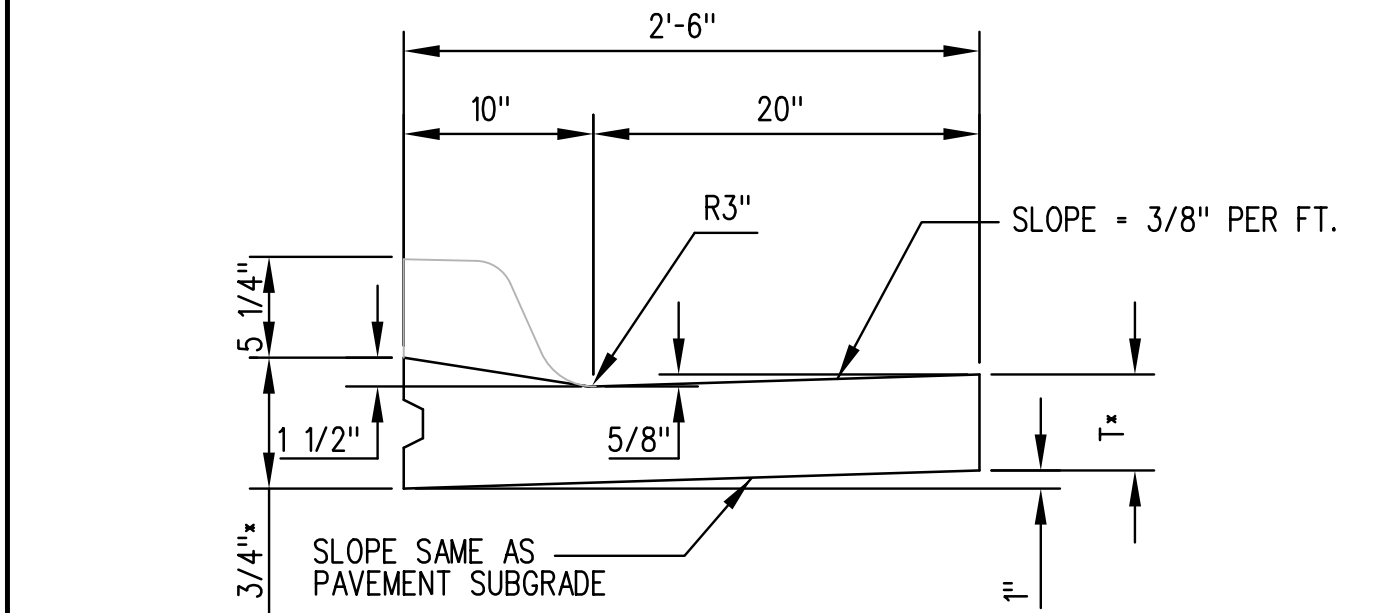

COMBINED CURB & GUTTER (1 1/2")

T* = THICKNESS OF CURB TO ADJUST WITH PAVEMENT THICKNESS

GENERAL NOTES

1. EXPANSION (ISOLATION) JOINTS SHALL BE CONSTRUCTED A MAXIMUM OF 300' APART AND AT ALL PIS, PCS, CUL-DE-SAC QUADRANTS, AND ENDS OF RETURNS.
2. CONTRACTION JOINTS SHALL BE CONSTRUCTED A MINIMUM OF 12' APART.
3. JOINT SEALER SHALL BE REQUIRED AT ALL JOINTS ON ARTERIAL AND INDUSTRIAL STREETS AND AT INTERSECTIONS ON RESIDENTIAL STREETS.

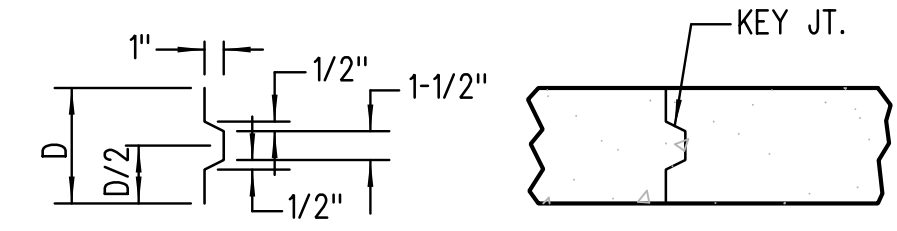
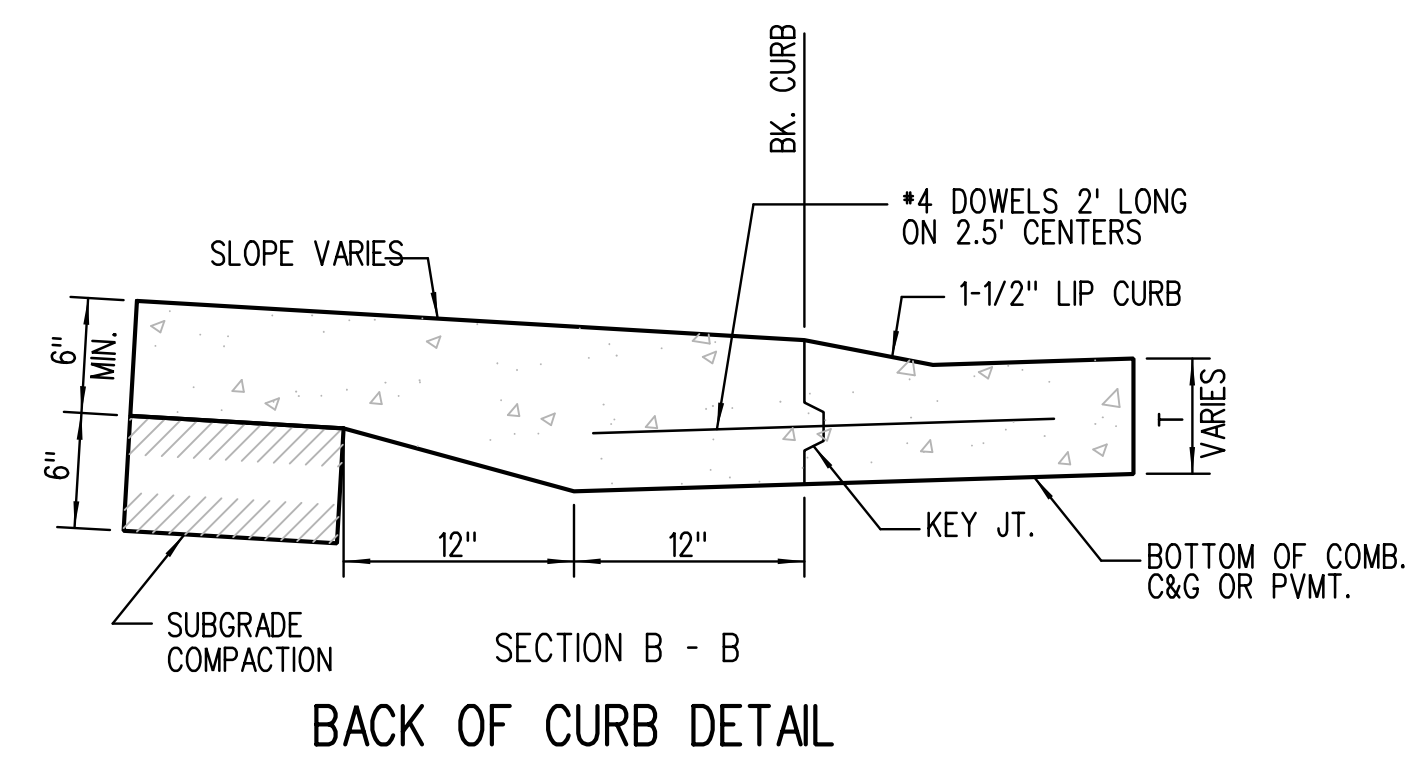

ALT. LONGITUDINAL CONSTRUCTION JOINT

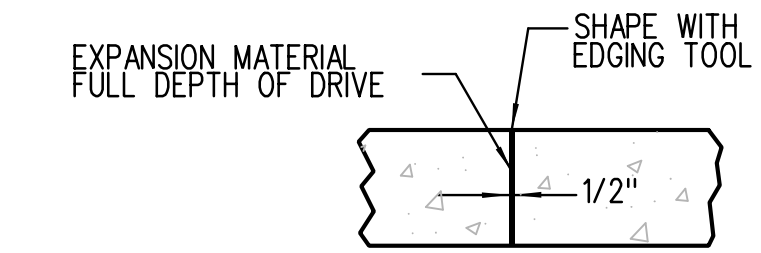

EXPANSION JOINT (E.J.)

Plotted By: cp Date: 12/30/2013 2:39:12 PM
 FILE: I:\2009\09521\Standards\09521-PV-101_Curb_&_Gutter.dwg



CURB & GUTTER DETAILS		
CITY ENGINEER GARY JANZEN, P.E.		
PROJECT NUMBER 472-85066	OCA NUMBER 707041	DATE 12/2010
CITY ENGINEER'S OFFICE CITY HALL - SEVENTH FLOOR 455 NORTH MAIN STREET WICHITA, KANSAS 67202-1620 (316) 268-4501		DESIGN DRAWN SHEET 59 of 388