

SECTION A-A

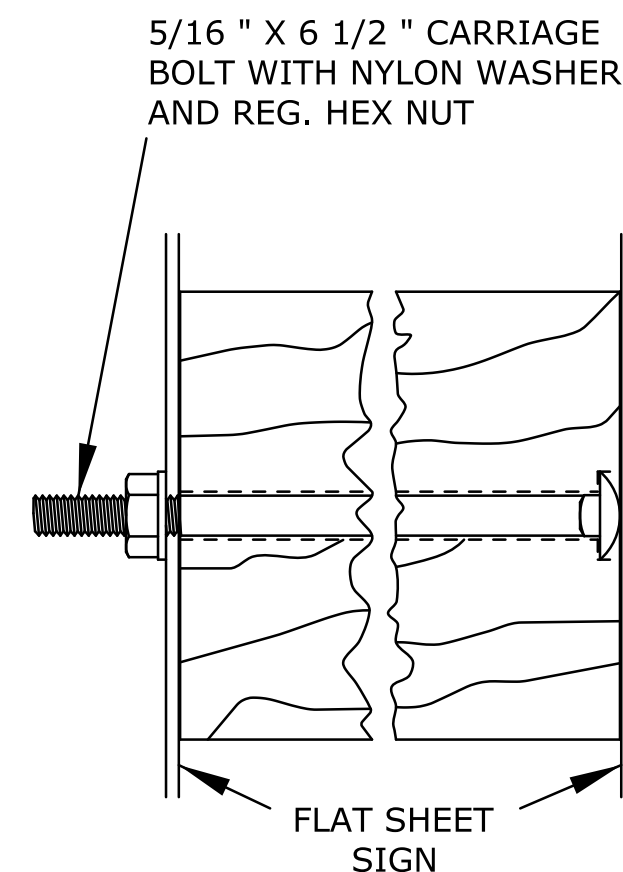

SECTION B-B

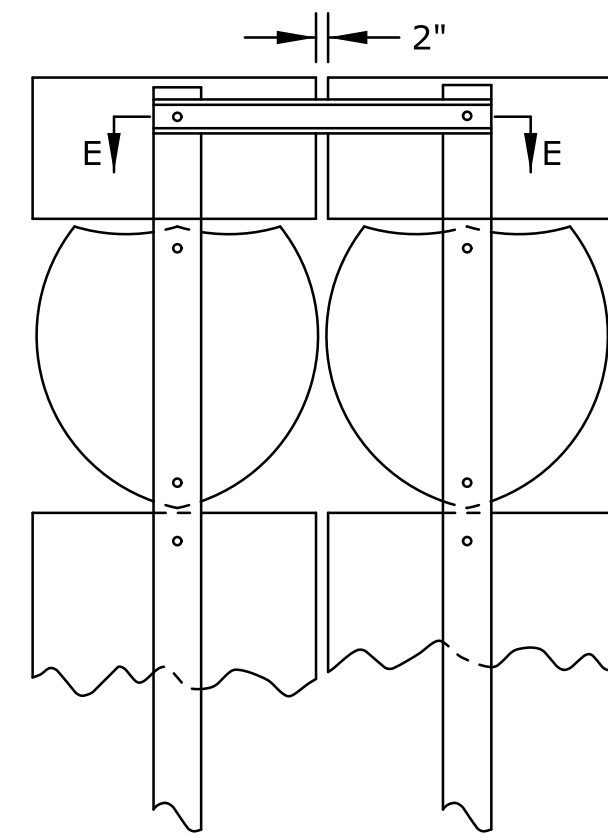

ROUTE MARKER ASSEMBLY ATTACHMENT

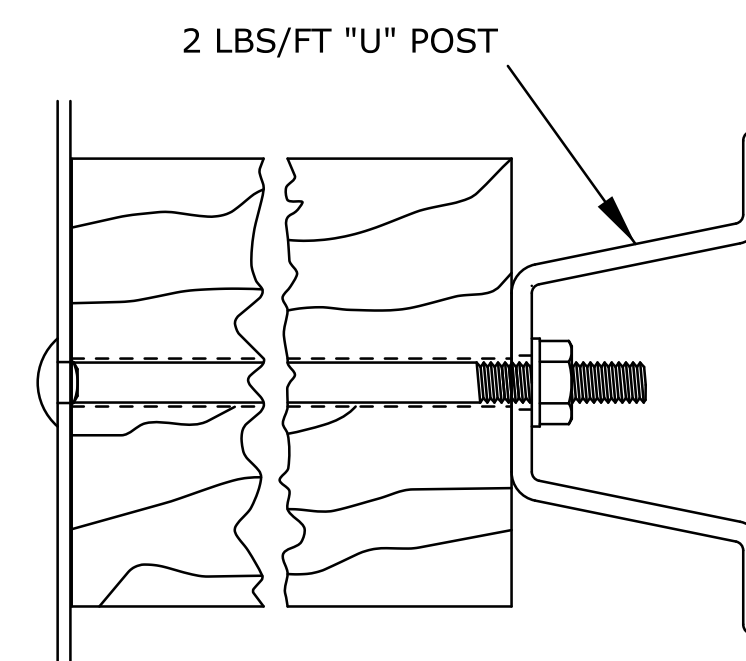

SECTION E-E

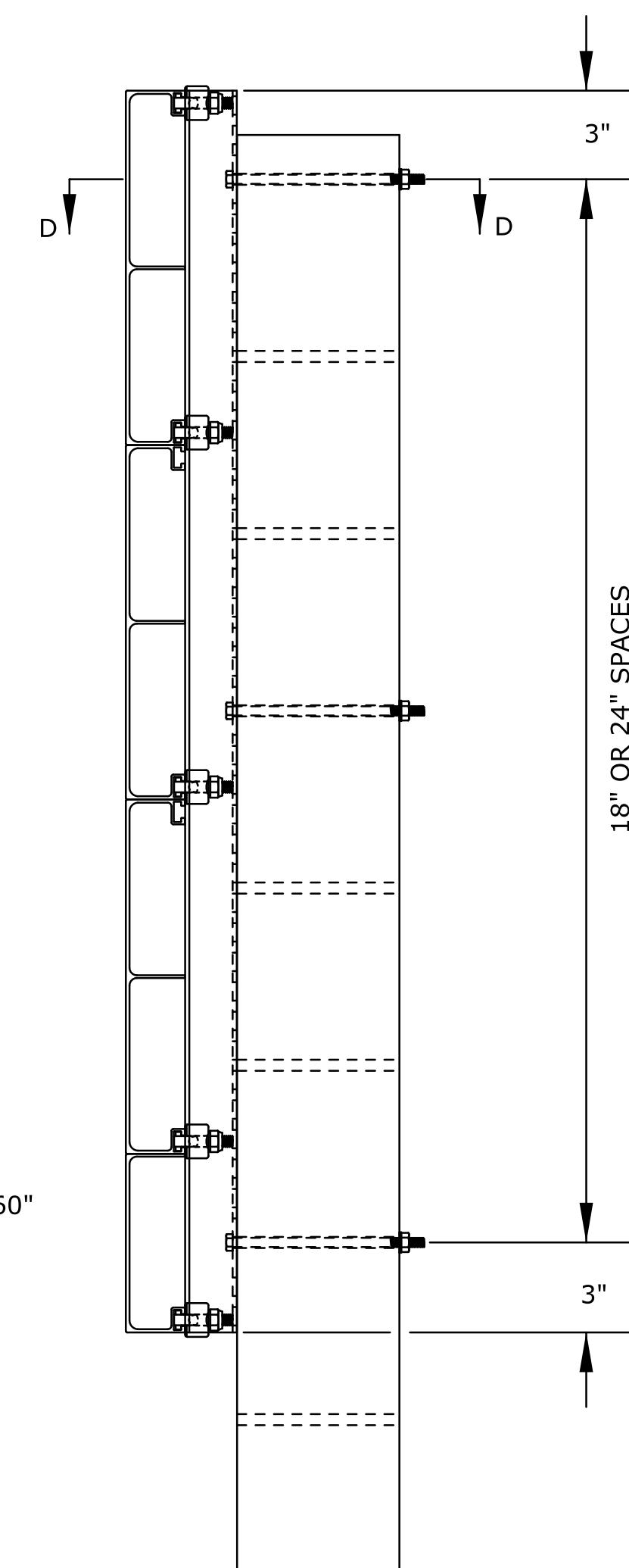

TYPICAL MOUNTING OF REINFORCED PANEL SIGNS

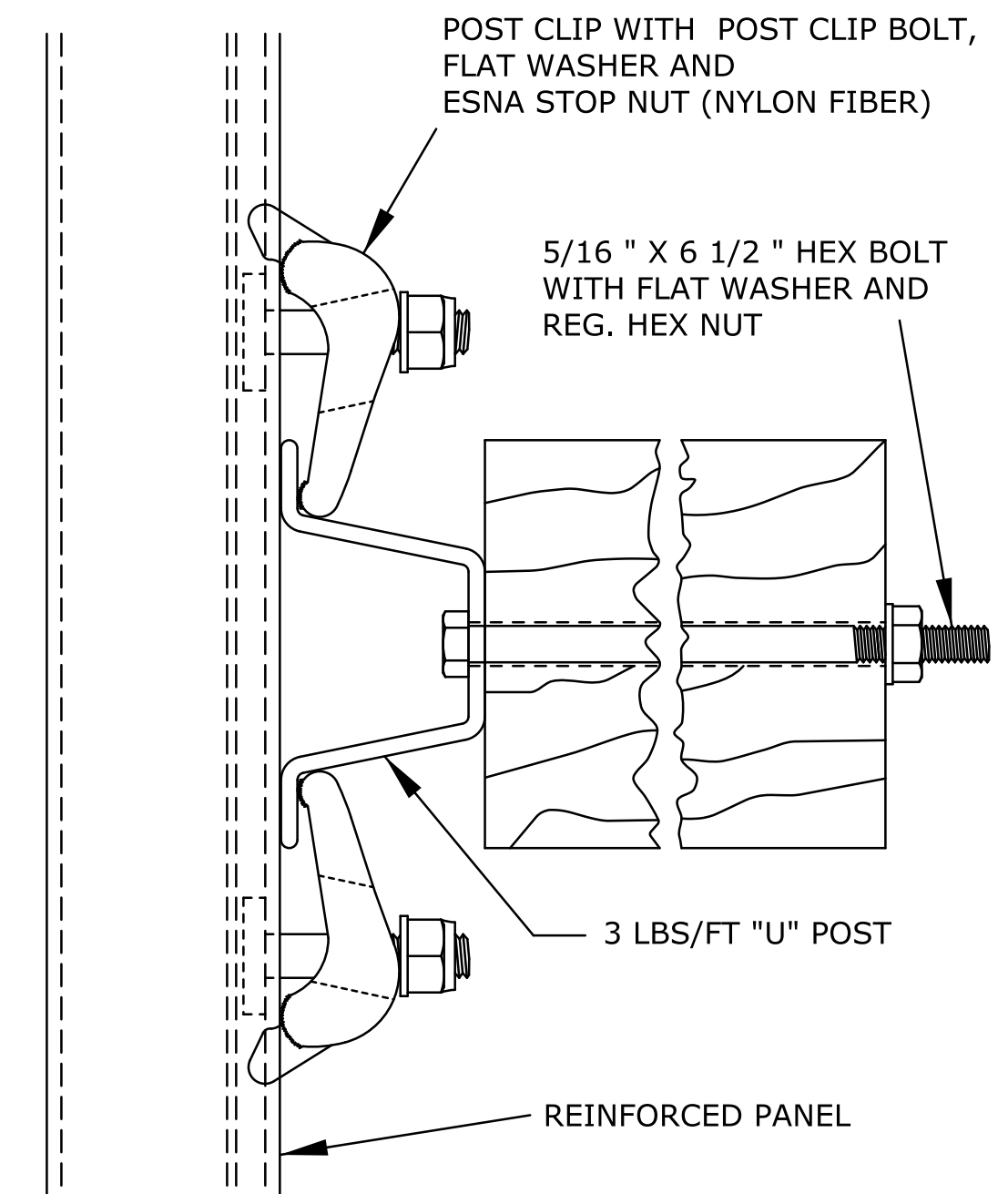

TOP VIEW

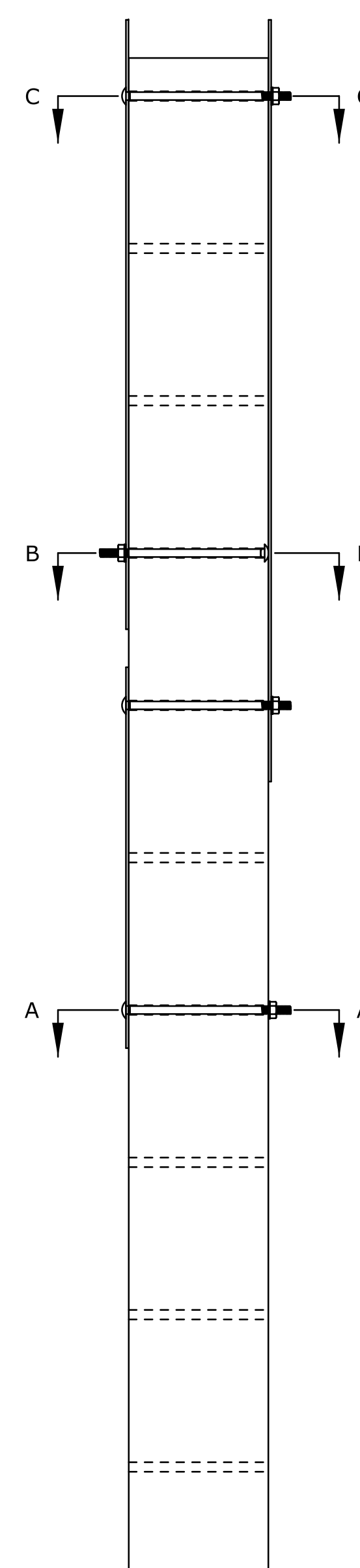

TYPICAL MOUNTING OF FLAT SHEET SIGNS

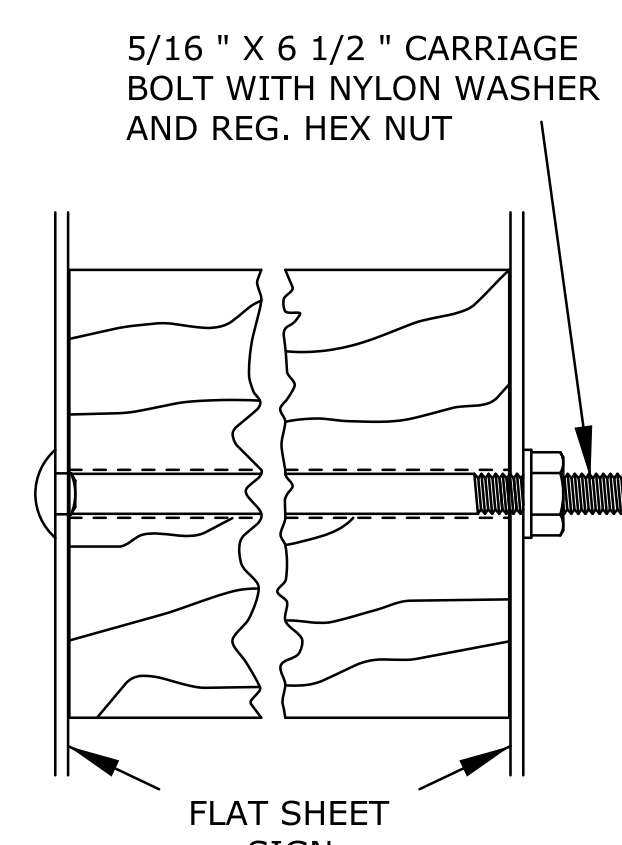

SECTION C-C

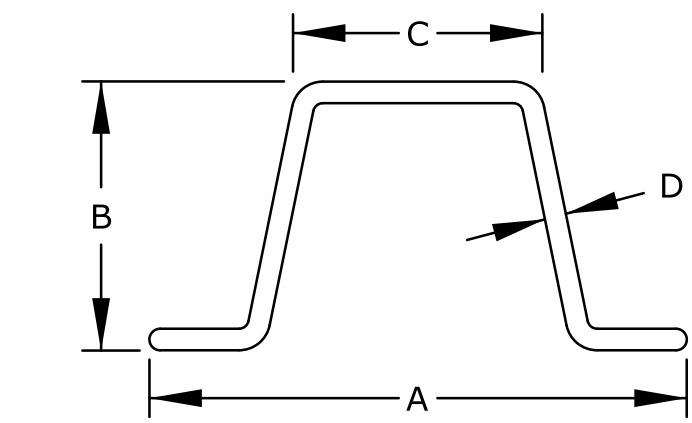

DIM.	2 LBS/FT	3 LBS/FT
A	3 1/8"	3 1/2"
B	1 17/32"	1 3/4"
C	1 1/4"	1 5/8"
D	1/8"	9/64"

(DIMENSIONS ARE NOMINAL)

'U' POST DIMENSION DETAILS

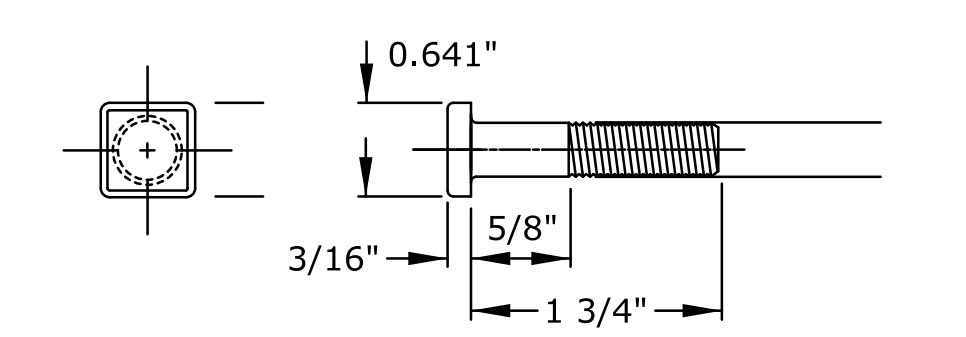

POST CLIP BOLT

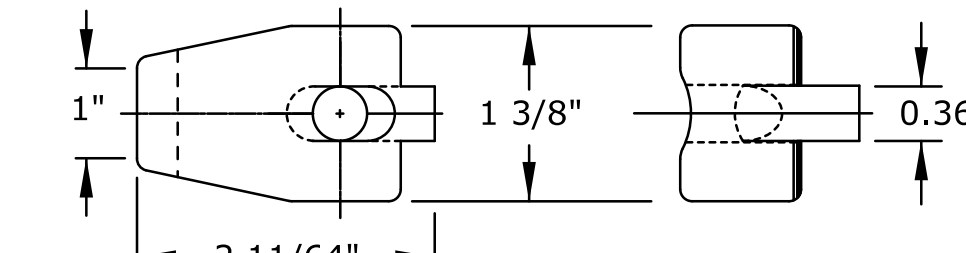

POST CLIP

NOTES:

THE TOP OF THE POST SHALL NOT EXTEND ABOVE THE TOP OF THE SIGN.

WHEN SIGNS ARE MOUNTED BACK TO BACK, THE SIGNS SHALL BE MOUNTED AT THEIR PRESCRIBED HEIGHT. IN GENERAL INSTALLATIONS, THE BOTTOM HOLES OF THE SIGNS SHOULD BE ALIGNED. IN ORDER TO PREVENT HAVING TO DRILL HOLES IN THE SIGNS OR POSTS, THE SIGN ON THE BACK SHOULD BE RAISED AND POSITIONED SUCH THAT THE HOLES ARE ALIGNED. WHEN A SIGN IS MOUNTED ON THE BACK OF THE "YIELD" (R1-2) SIGN, THE TOP HOLES OF THE SIGNS SHOULD BE ALIGNED.

WHEN MOUNTED WITH ANOTHER SIGN (PRIMARY SIGN), THE ADVISORY PLATE, TYPE 1 OBJECT MARKER, OR SECONDARY SIGN, SHALL BE MOUNTED AT THEIR PRESCRIBED HEIGHT. THE PRIMARY SIGN SHALL BE MOUNTED AT THEIR PRESCRIBED HEIGHT, BUT UNDER NO CIRCUMSTANCES SHALL THE SIGNS OVERLAP EACH OTHER.

ADDITIONAL MOUNTING HOLES, EITHER THROUGH THE SIGN OR POST, SHALL BE DRILLED BY THE CONTRACTOR. ALL HOLES DRILL IN THE POST SHALL BE TREATED WITH A PRESERVATIVE. ALL HOLES IN THE SIGN SHALL BE FREE OF ANY DEFECTS AND THE SHEETING AROUND THE HOLE SHALL NOT BE DAMAGED.

A NYLON WASHER SHALL BE USED WHEN A NUT IS TO BE TIGHTENED AGAINST THE SIGN FACE.

WHEN THE 2 LBS/FT STEEL "U" POST IS USED AS A ROUTE MARKER ASSEMBLY ATTACHMENT, IT SHALL BE SUBSIDIARY TO THE BID ITEM '4" X 6" WOOD POST (FLAT SHEET SIGN)'.

THE POST CLIP BOLT MAY HAVE A RECTANGULAR HEAD, IF THE SMALLER DIMENSION IS EQUAL TO THE SQUARE HEAD DIMENSION.

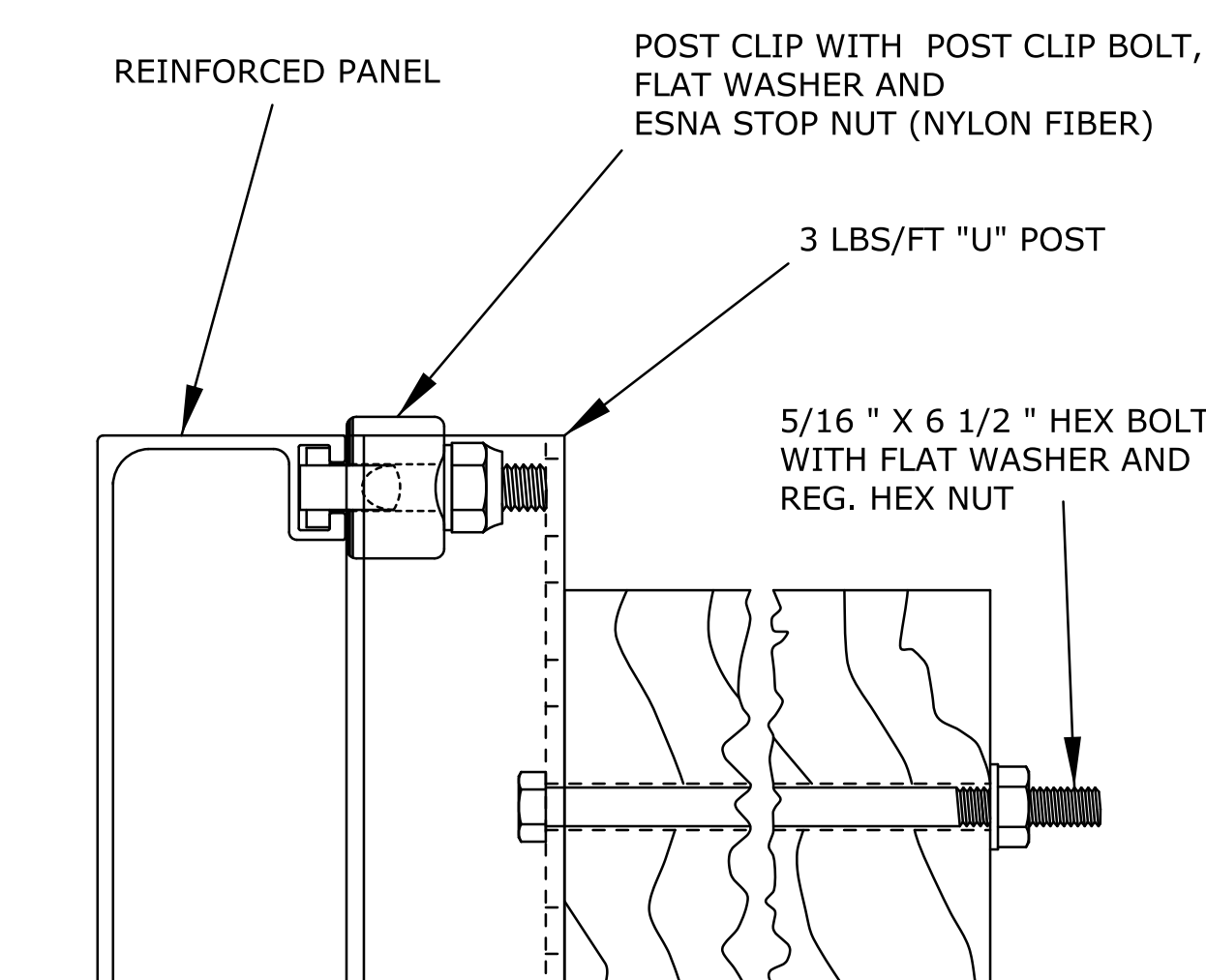

SIDE VIEW

SECTION D-D

ALL DIMENSIONS ARE IN INCHES

NO.	DATE	REVISIONS	BY	APP'D
KANSAS DEPARTMENT OF TRANSPORTATION DETAILS FOR MOUNTING SIGNS ON WOOD POSTS				
FLAT SHEET AND REINFORCED PANEL TE48I				
7/1/03				
FHWA APPROVAL		T-22-2003		APP'D
DESIGNED	D.D.G.	DETAILED	A.A.D.	QUANTITIES
DESIGN CK.	S.A.B.	DETAIL CK.	D.D.G.	QUAN. CK.
				Steven A. Buckley
				TRACED
				TRACE CK.