

STATE	PROJECT NO.	YEAR	SHEET NO.	TOTAL SHEETS
KANSAS	472-85066	2014	225	388

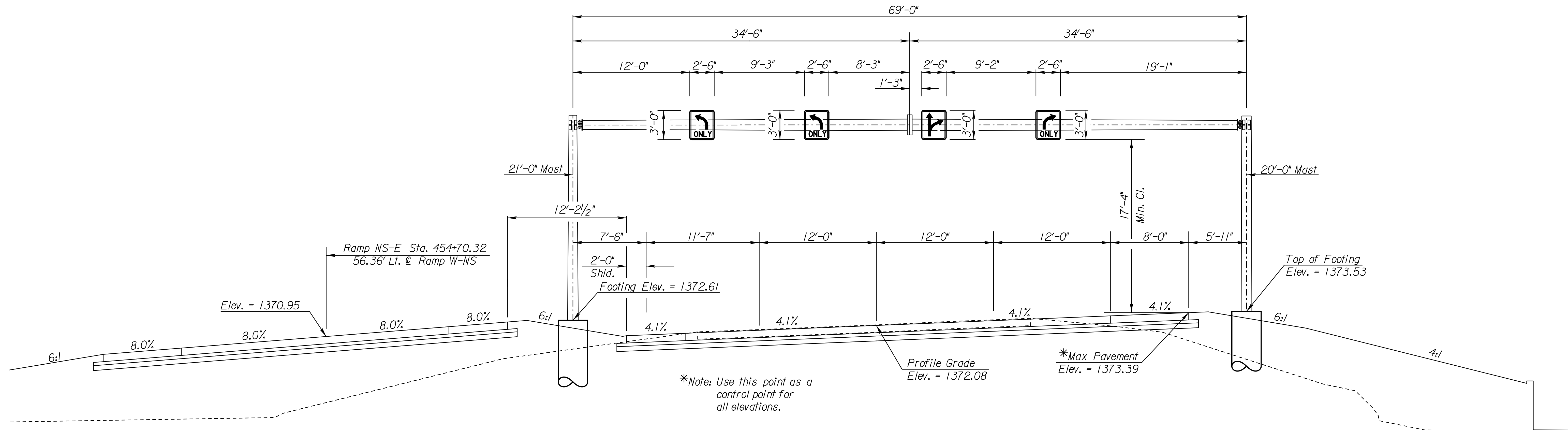

ELEVATION
 @ Ramp W-NS Sta. 460+85
 (Looking Southeast)

Plotted By: ap
 File: I:\2009\0921\Overhead Signing - KD07\EN35700\POS28.dgn
 Plot Date: 31-DEC-2013 11:27

3					
2					
1					
NO.	DATE	REVISIONS	BY	APP'D	
KANSAS DEPARTMENT OF TRANSPORTATION Ramp W-NS Sta. 460+85 Tapered Tube Type Overhead Sign Structure Construction Layout Proj. No. 096-87 EN-3570-01 Sedgwick Co.					
SHEET NO.	OF	SCALE	APP'D	DESIGNED	QUANTITIES
DESIGN CK.	DETAIL CK.	QUAN. CK.	CADD CK.	CADD CK.	CADD CK.