

PLAN

(Only lower truss members shown.)

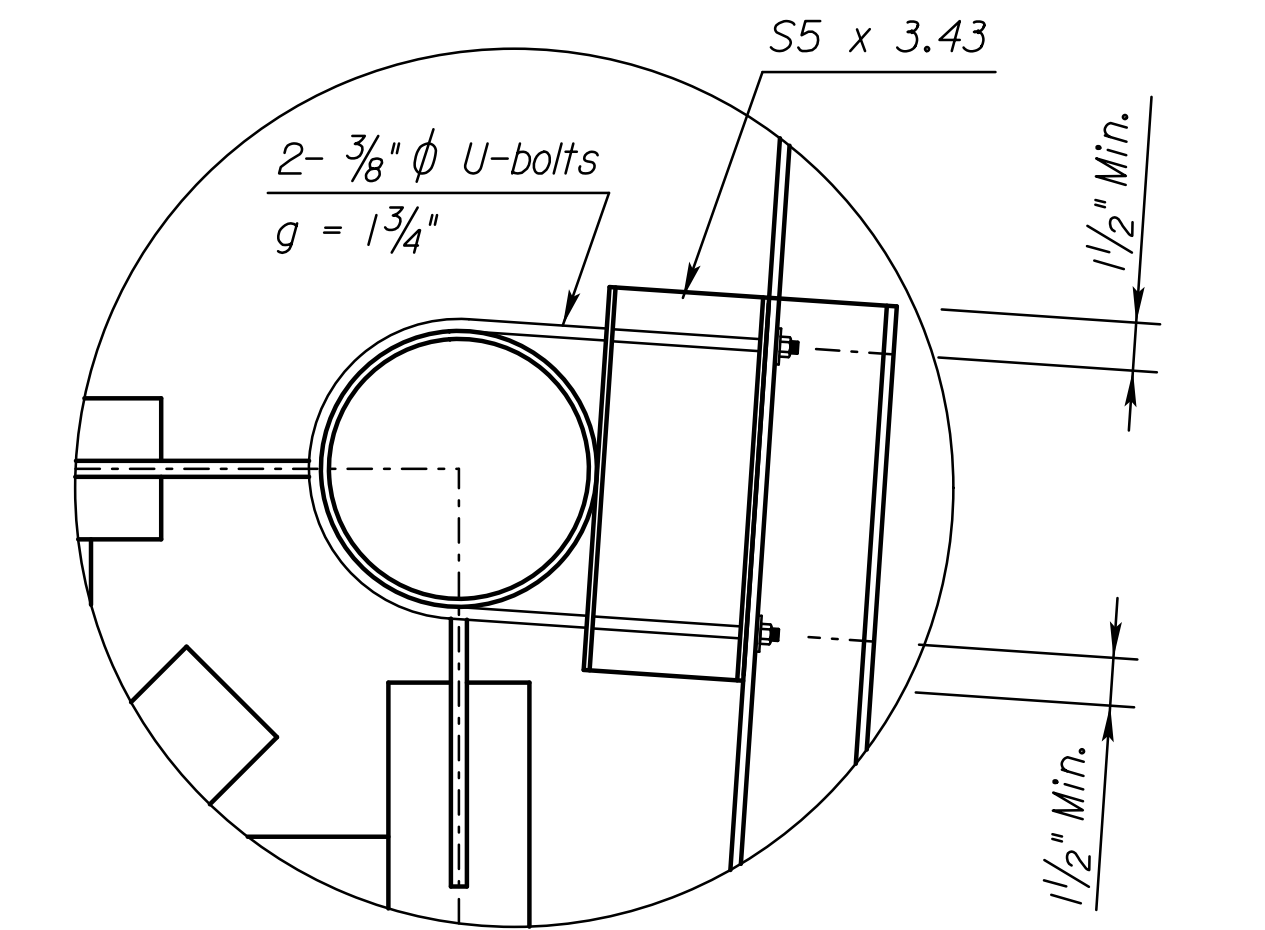

Detail C

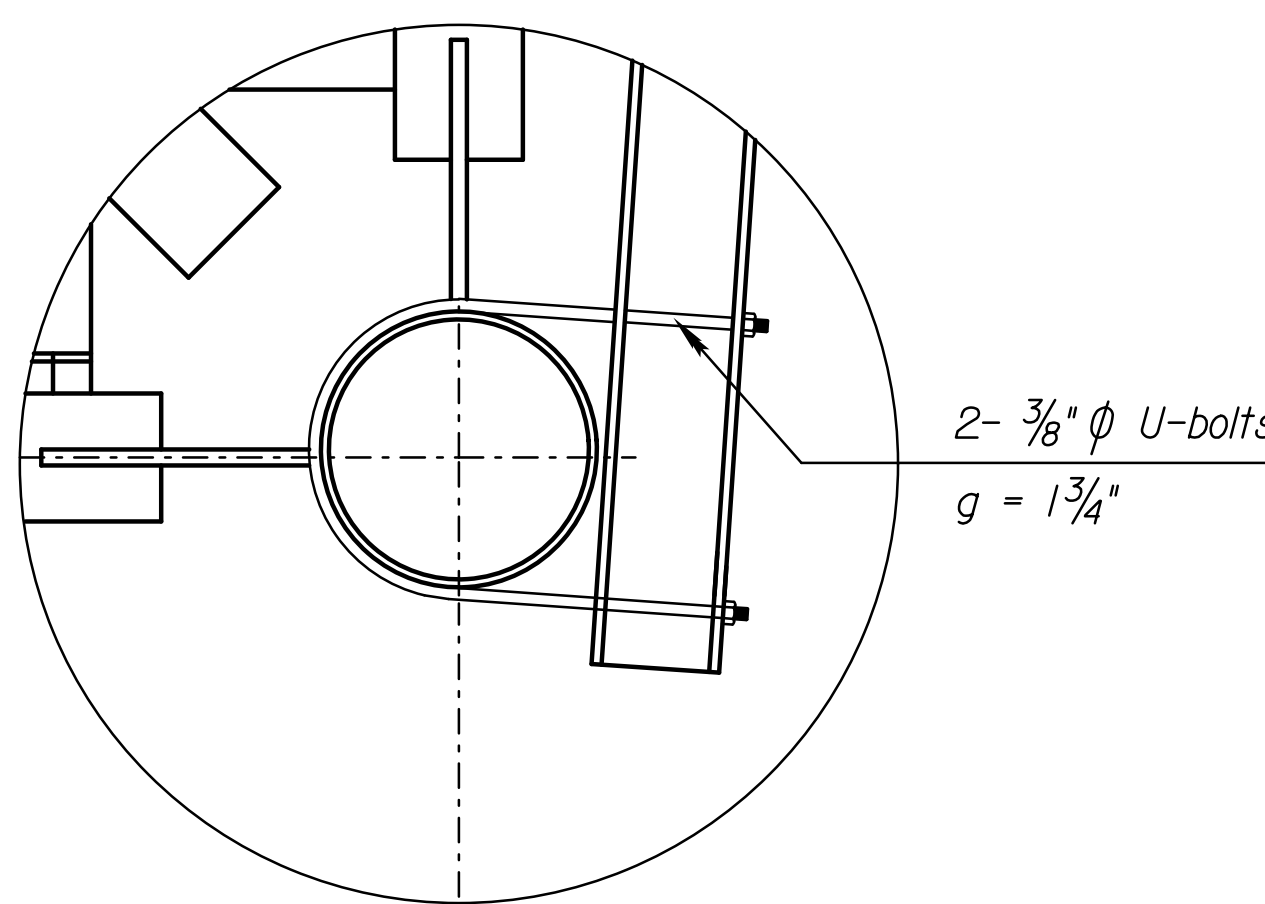

Detail B

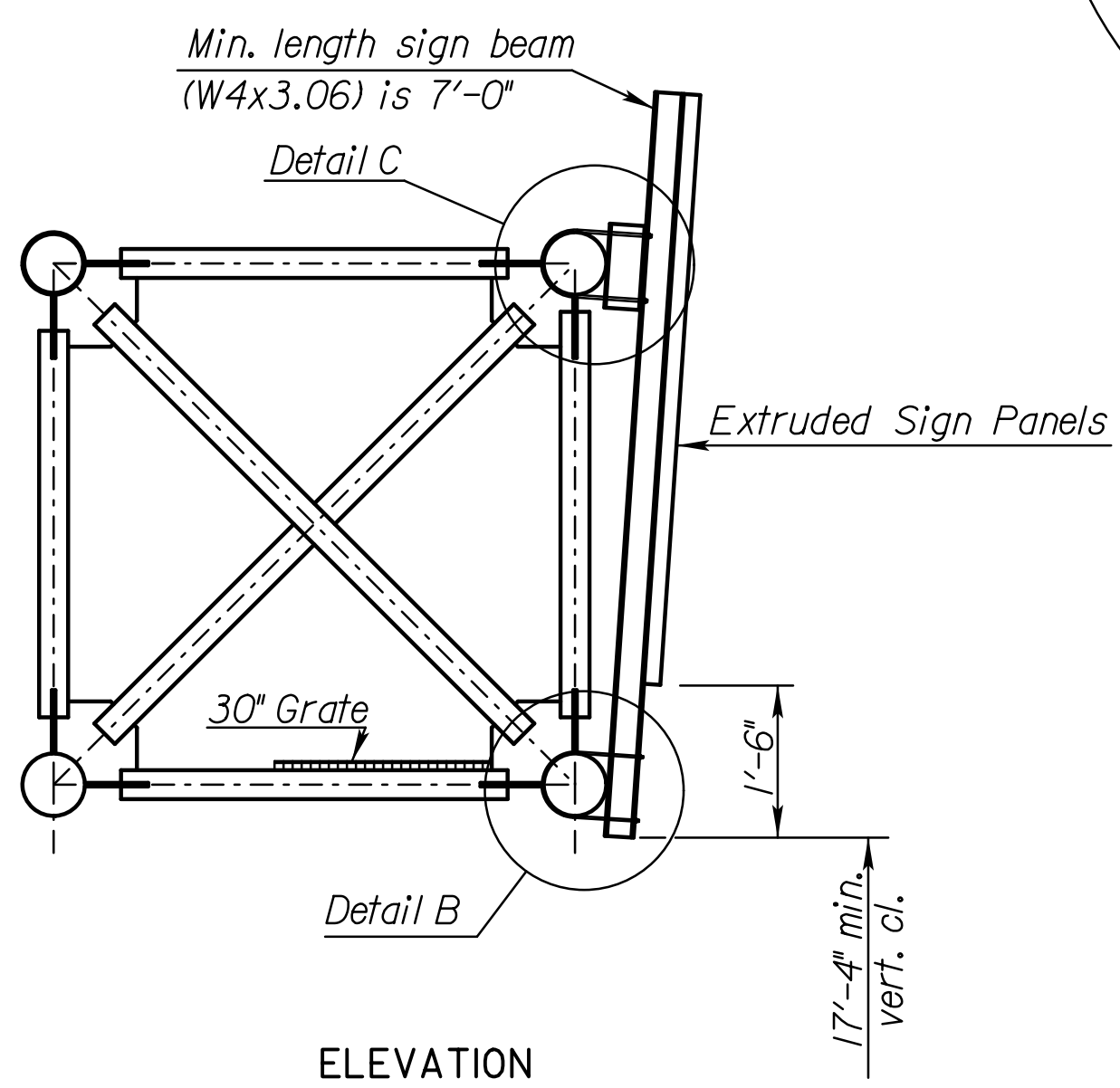

ELEVATION

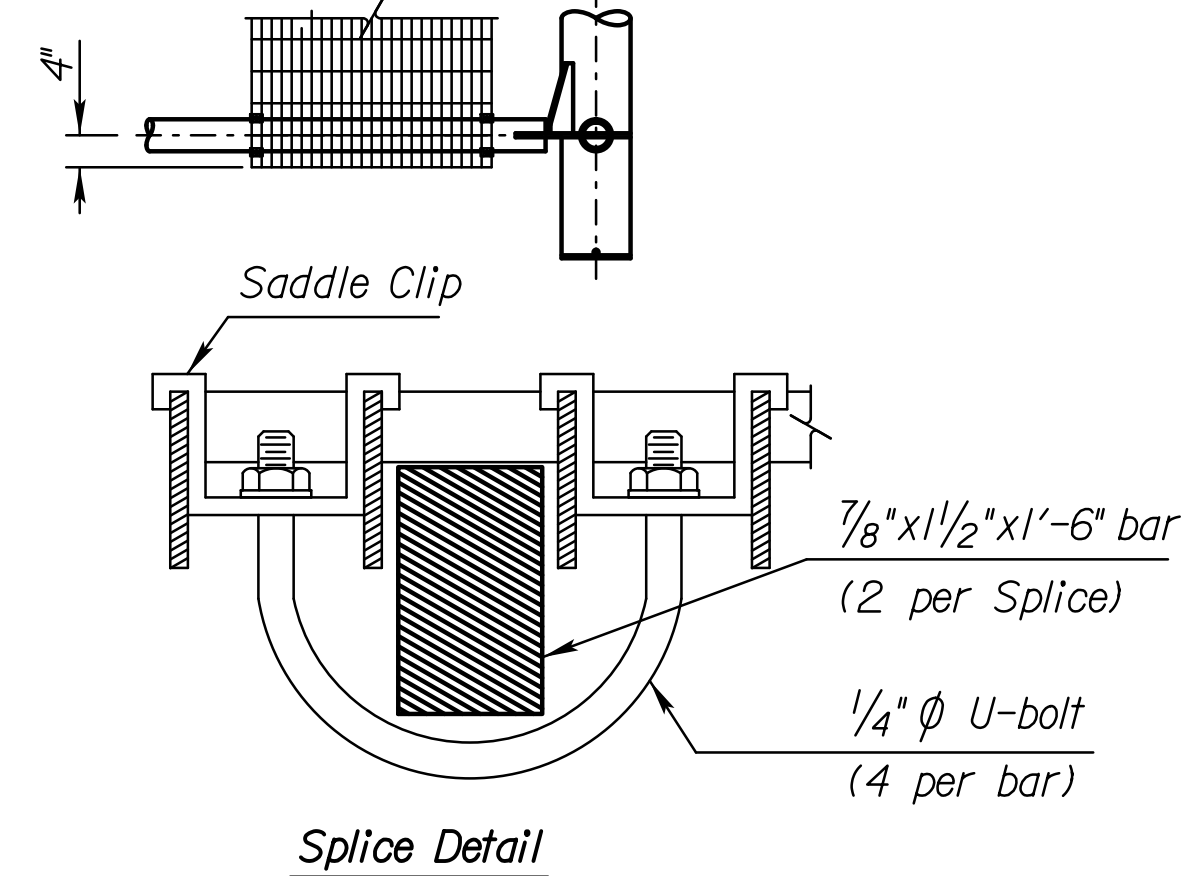
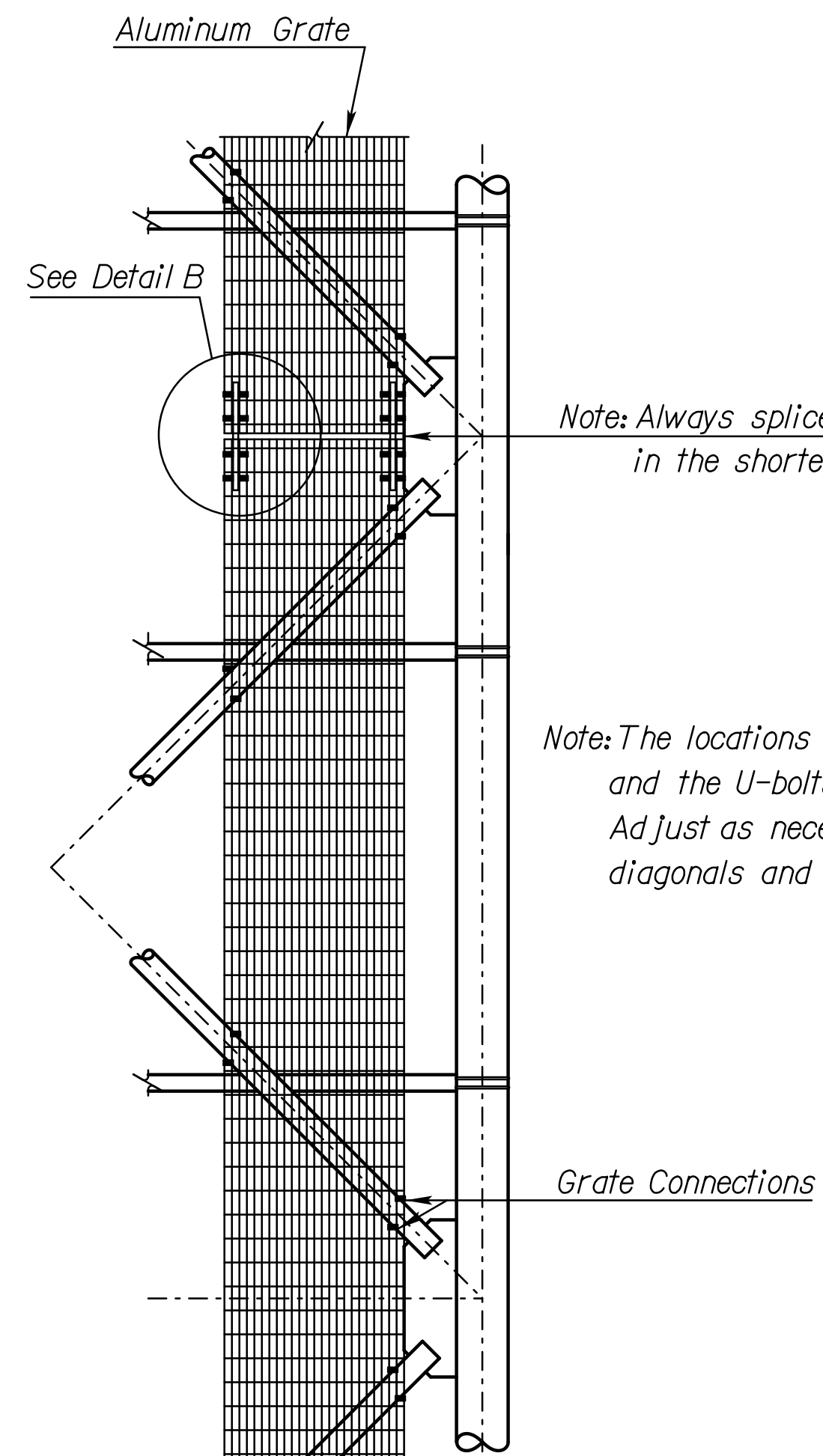

INTERIOR GRATE CONNECTION DETAILS

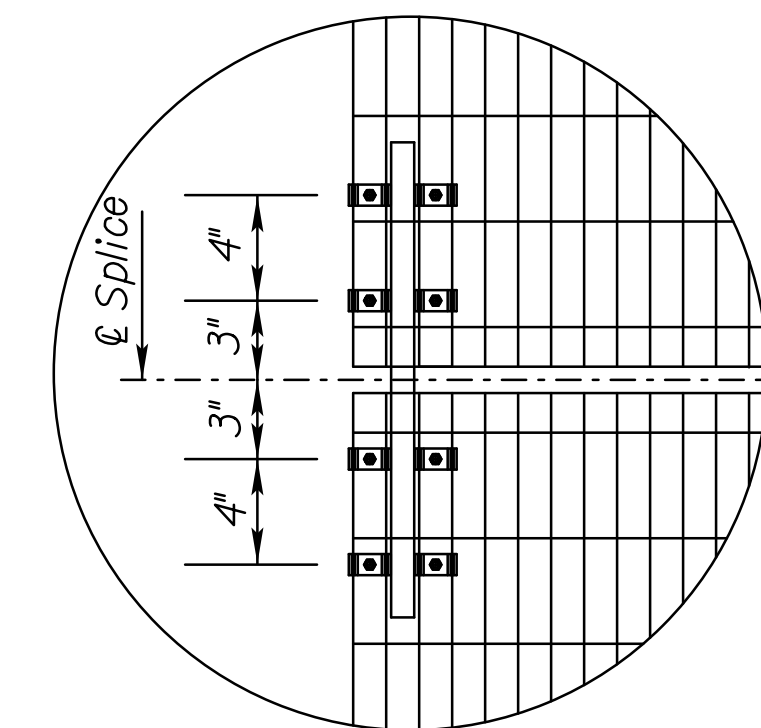

Detail B

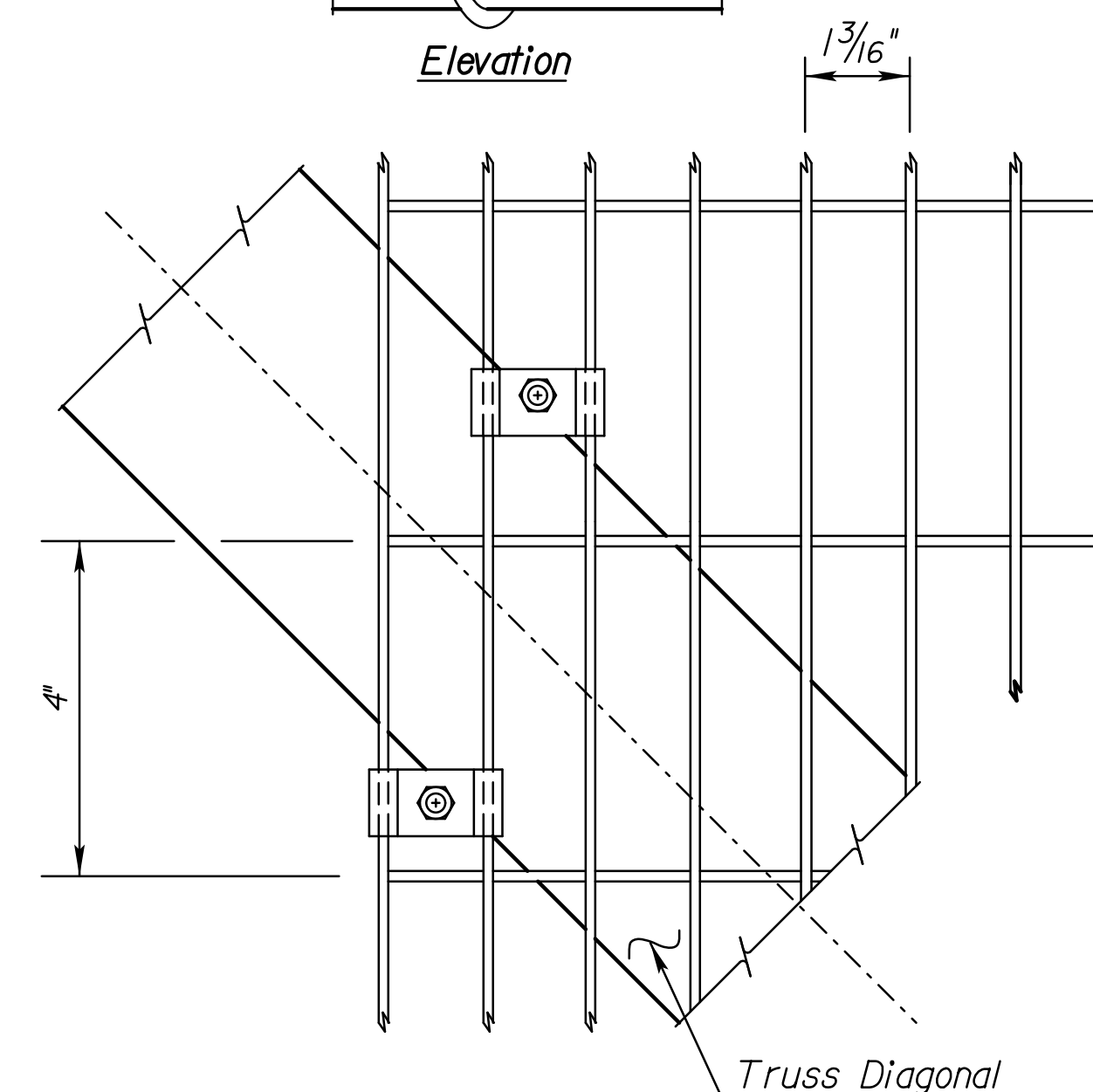
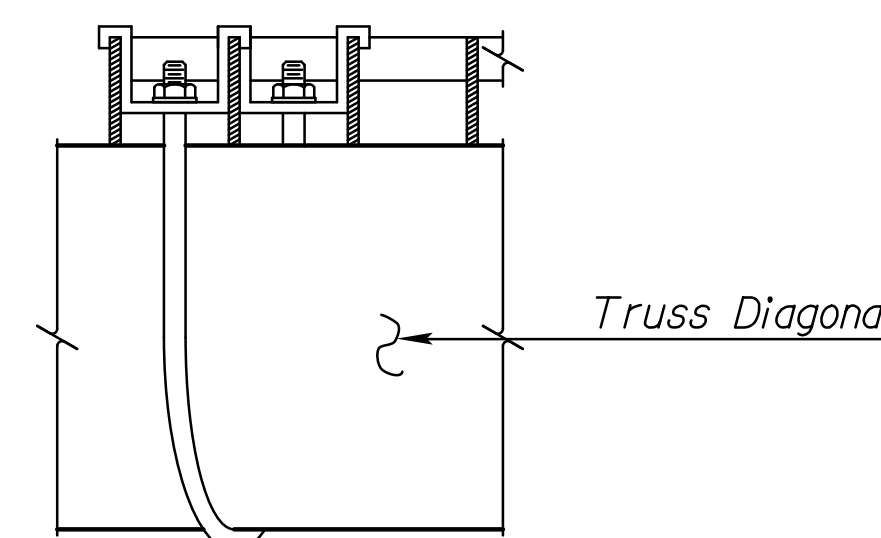

Standards SL15B-08 and SL15B-09 were combined

Std. Base File: Plot Location: Plotted By: ap File: I:\2009\0952\Overhead Signing - KDOT\EN35700\POS19.dgn Plot Date: 30-DEC-2013 16:22

NO.	DATE	REVISIONS	BY	APP'D
I	5/11/11	SL15B-08 & SL15B-09 combined exterior grate taken off	KMP	TLF

KANSAS DEPARTMENT OF TRANSPORTATION
STANDARD STRUCTURAL SIGN SUPPORTS
SPAN TYPE OVERHEAD
ALUMINUM SIGN MOUNTING AND
WALKWAY DETAILS

SL15B-08

DESIGNED	BFMI	3-14-94	APP'D	Terry L. Fleck
DETAIL	CK.	JD/RD	QUANTITIES	DJE
DESIGN	CK.	KFH	QUAN.	LES