

STATE	PROJECT NO.	YEAR	SHEET NO.	TOTAL SHEETS
KANSAS	472-85066	2014	240	388

GENERAL NOTES

LOADING: AASHTO Standard Specifications for Structural Supports for Highway Signs, Luminaires and Traffic Signals, 2009 Edition with current interims.

CONCRETE: Use Grade 4.0 concrete throughout. Concrete shall be rodded or vibrated. Form the footing from the top to one foot below ground as shown. Bevel all exposed edges with a 3/4" triangular molding.

STRENGTH: The curing time shall be a minimum of 15 days or until a test cylinder achieves a compressive strength of 4.0 ksi or greater.

REINFORCING: All dimensions relative to reinforcing steel are to center line of bar unless otherwise noted.

EXCAVATION: Footing holes shall be carefully drilled to the required size at the proper location. All excavation shall be disposed of within the right-of-way in such a manner as to blend uniformly with the existing surface and as approved by the Engineer. Immediately before placing any concrete, the Contractor shall remove all loose and uncompacted material from the bottom of the hole.

CASING: To prevent the collapse of the excavations, drilled shafts shall require temporary casing unless exempted by the Engineer.

BACKFILL: All soil used for backfilling of footing excavation shall be thoroughly compacted as it is placed. The backfill shall be brought up to the finished ground line adjacent to the footing.

ANCHOR BOLTS: Anchor bolts will adhere to KDOT Standard Specification Section 1600 (Grade 55) with the following exception: cut threads are not permitted. Welding shall conform to the "Standard Specifications for State Road and Bridge Construction and the latest edition of the American Welding Society.

DIRECT TENSION INDICATORS: DTIs are to comply with the requirements of the latest edition of ASTM F2437 and provide proof load shown in the table. Installation will adhere to the KDOT Standard Specifications.

EXISTING FACILITIES: Any existing facilities (i.e., curb and gutter, guard fence, pavement, shoulders, etc.) that require removal in order to construct the footing, shall be restored to their original condition at the Contractor's expense. Concrete shall only be removed using sawed joints.

PAYMENT: The cost of all material and labor needed to construct its footing shall be included in the unit price bid for each Cantilever and Butterfly Type Overhead Sign Structure.

Dimension Design No.	Bolt Circle	A	B	C	CL	Spiral Dia.	N	* G	DTI Proof Load (Kips)
1	1'-10"	8'-0"	10 1/2"	2"	5 1/2"	2'-1"	8	1'-4 1/2"	114
2 & 3	2'-1 1/2"	8'-0"	10 1/2"	2"	3 1/2"	2'-5"	9	1'-4 1/2"	114
4, 5 & 6	2'-1 1/2"	8'-6"	11 3/16"	2 1/4"	3 1/2"	2'-5"	11	1'-5 3/16"	103

* Galvanizing Length

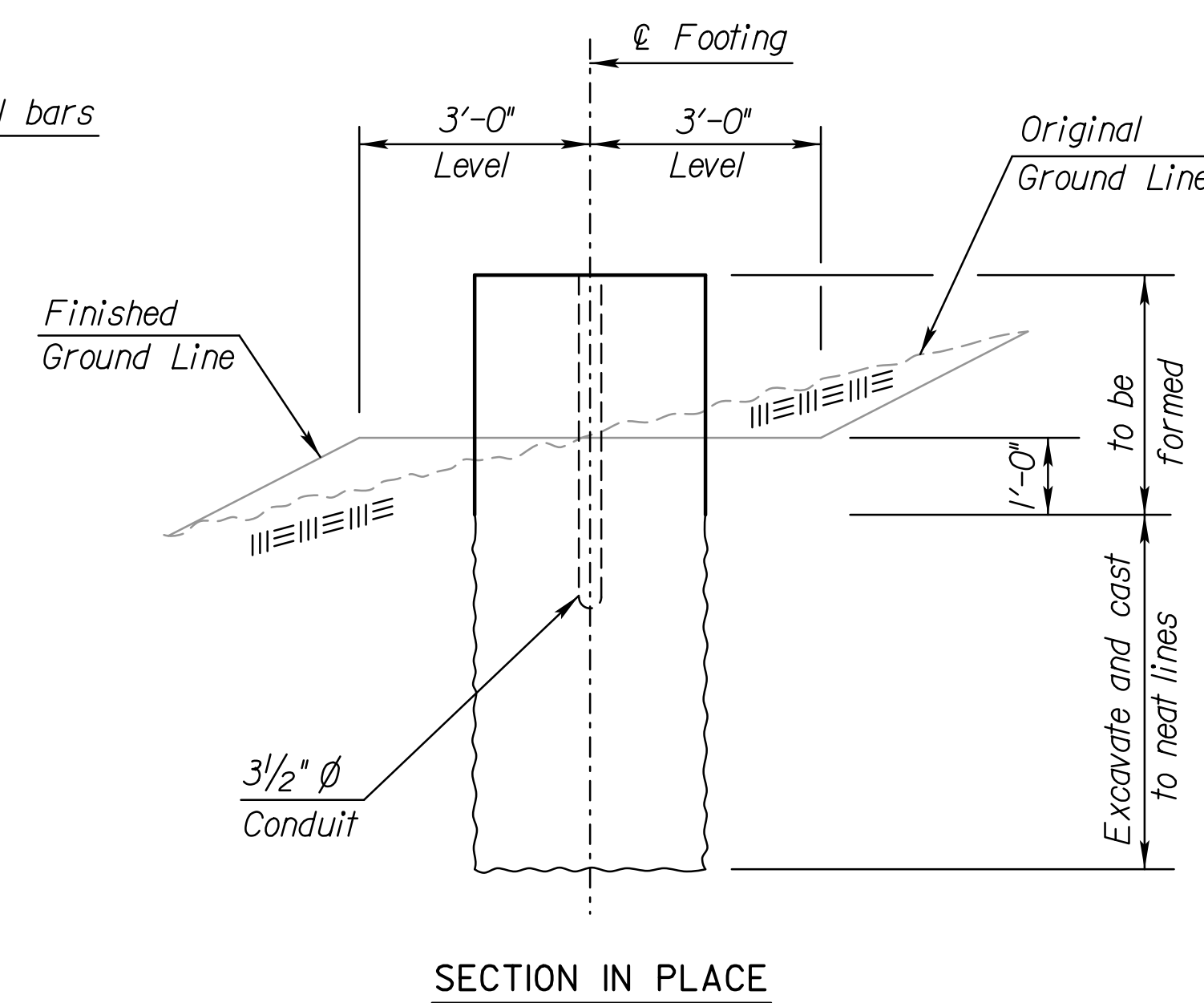
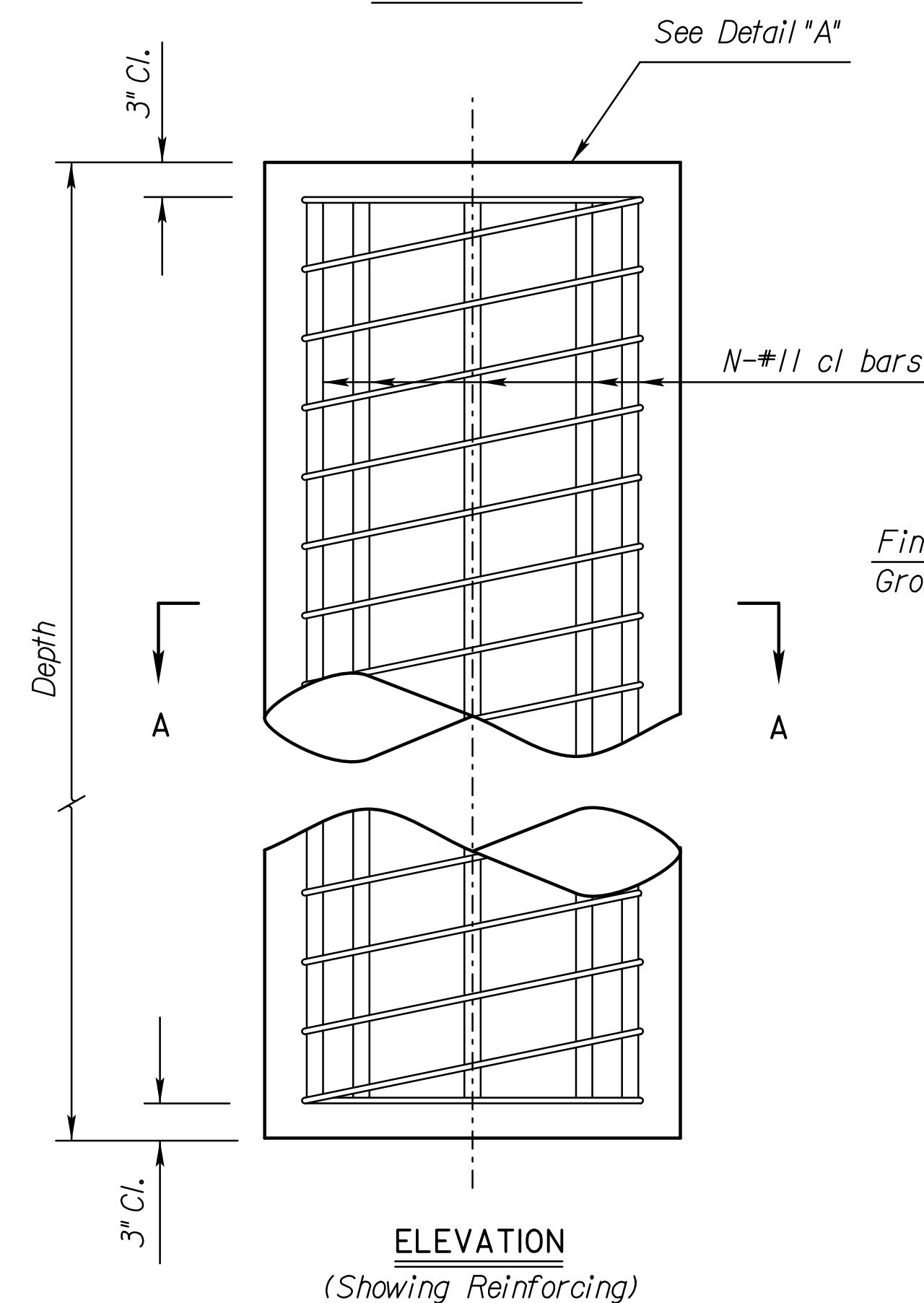
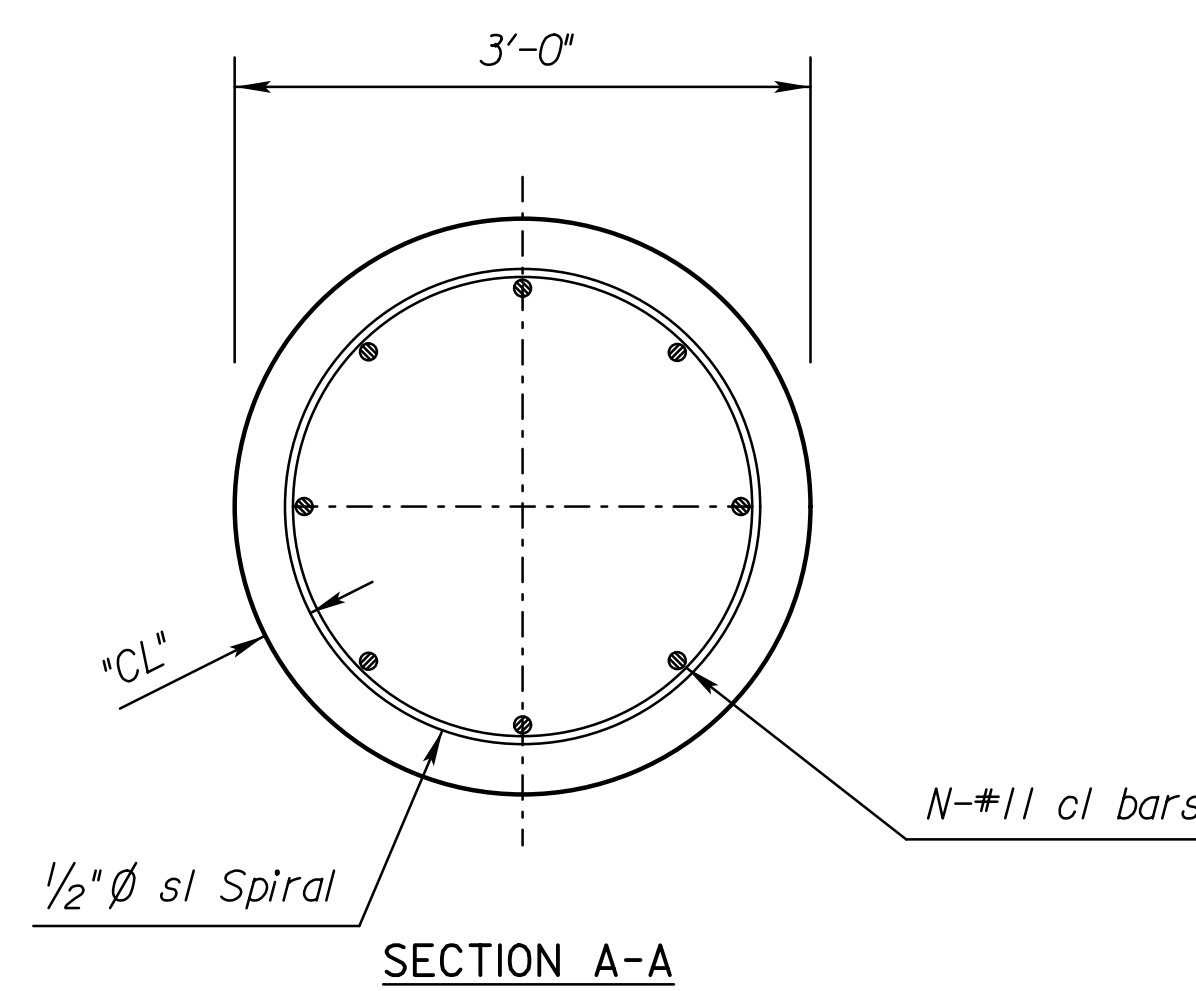

Type	Depth	"L"	Grade 4.0 Concrete Cu. Yds.	Reinforcing Steel			Class III Excavation Cu. Yds.
				Design #1 Lbs.	Design #2&3 Lbs.	Design #4-6 Lbs.	
A	9'-0"	8'-6"	2.4	470	530	620	1.8
B	10'-0"	9'-6"	2.6	520	590	690	2.1
C	11'-0"	10'-6"	2.9	580	650	760	2.4
D	12'-0"	11'-6"	3.1	630	710	830	2.6
E	13'-0"	12'-6"	3.4	680	770	900	2.9
F	14'-0"	13'-6"	3.7	740	830	970	3.1
G	15'-0"	14'-6"	3.9	790	890	1040	3.4
H & I	16'-0"	15'-6"	4.2	840	950	1120	3.7
J	17'-0"	16'-6"	4.5	900	1010	1190	3.9

Note: Quantities shown are for estimating purposes only.

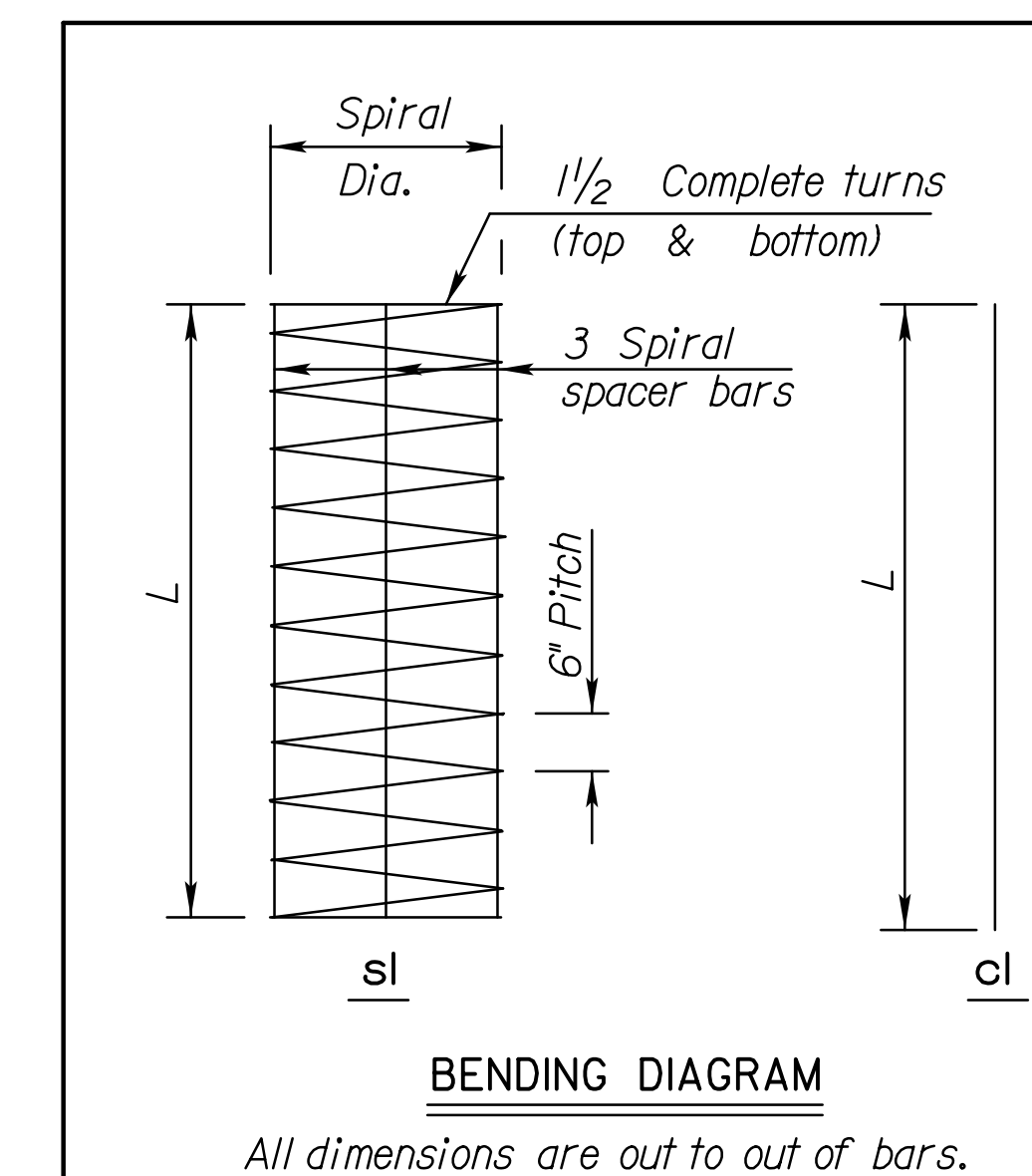
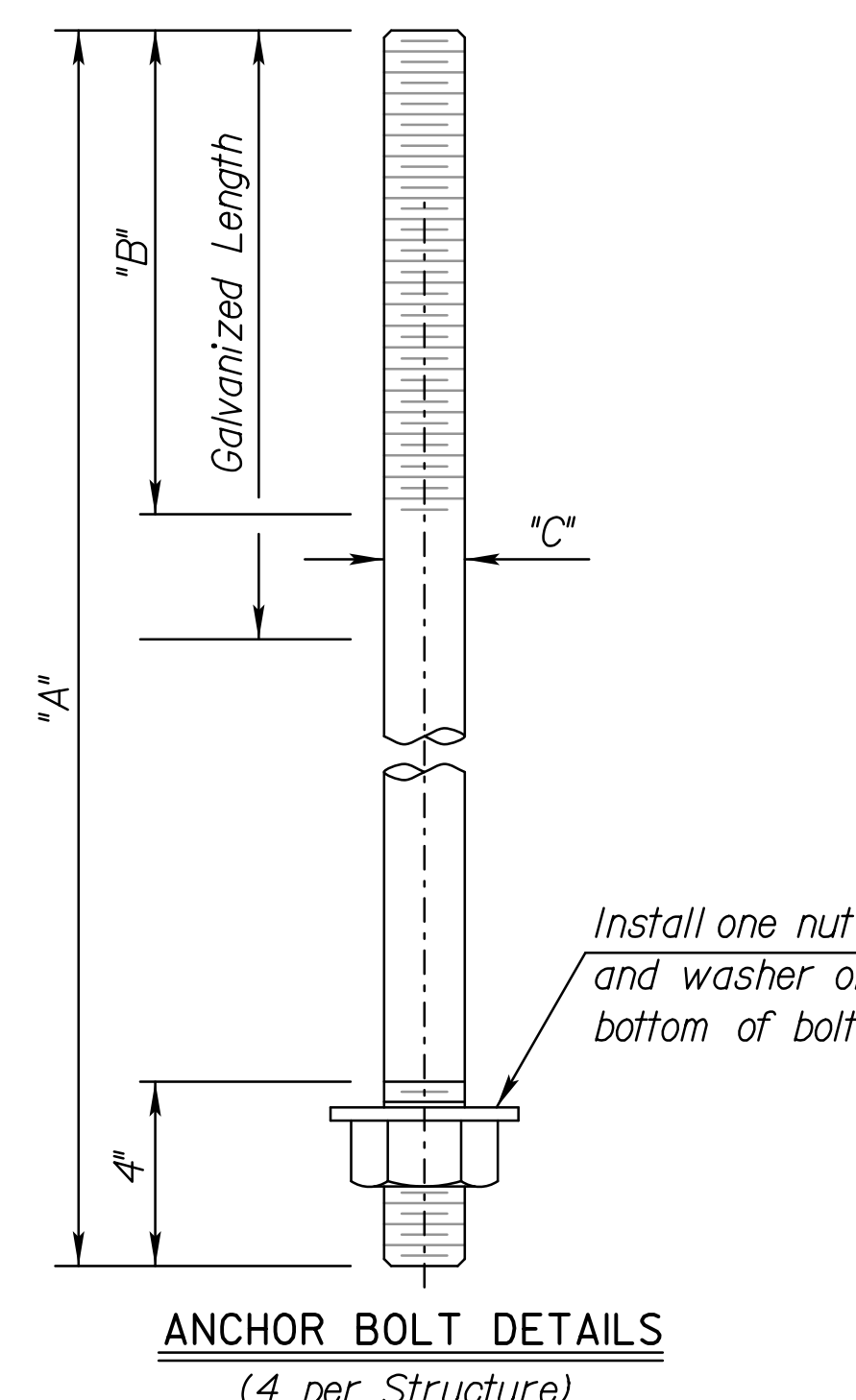
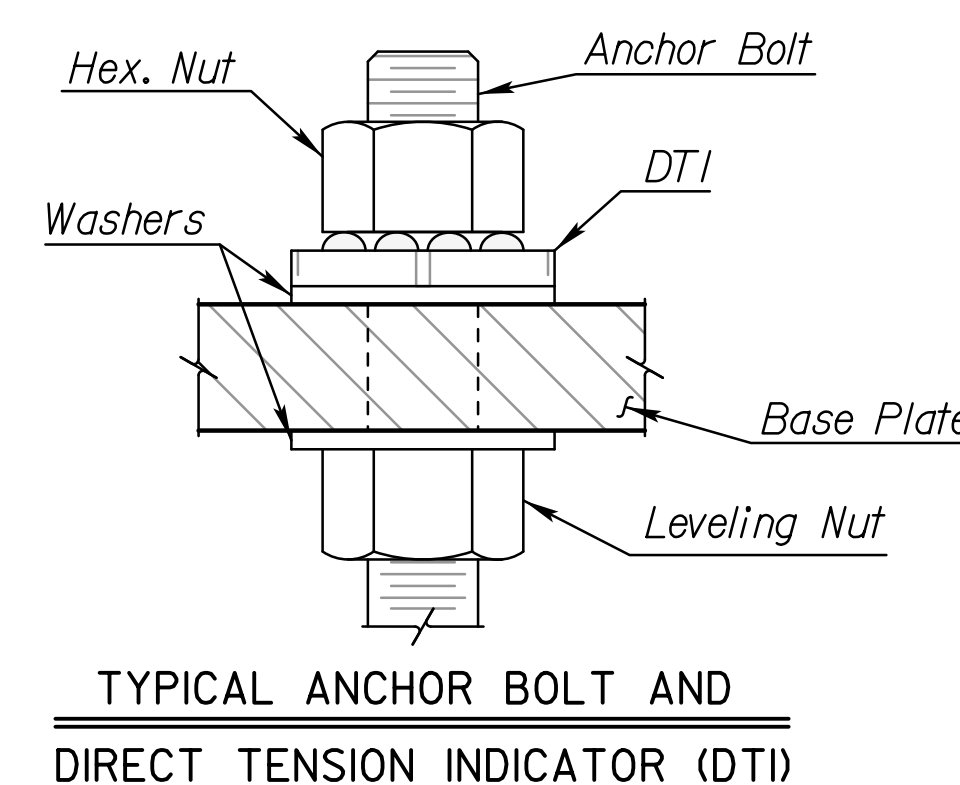
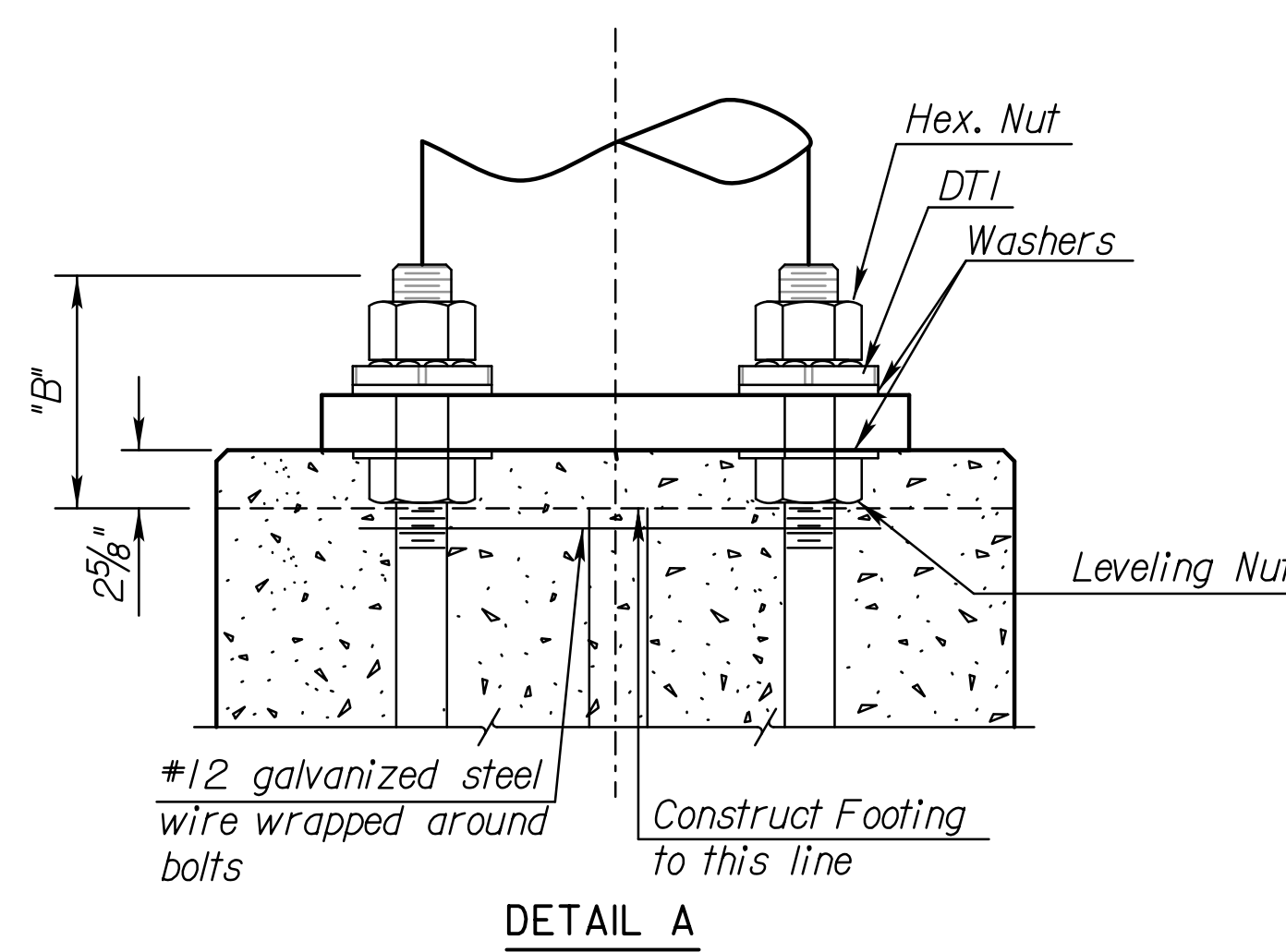

Std. Base File: Plot Location: Plot Location: File: I:\2009\0952\Overhead Signing - KDOT\EN35700\POS23.dgn Plot Date: 30-DEC-2013 16:22

KANSAS DEPARTMENT OF TRANSPORTATION				
NO.	DATE	REVISIONS	BY	APP'D
1	5/11/11	Updated notes and add DTI info	KMP	TLF
STANDARD STRUCTURAL SIGN SUPPORTS CANTILEVER AND BUTTERFLY TYPE OPTIONAL DRILLED SHAFT FOOTING DETAILS SL152A-03				
DESIGNED	LES	DETAILED	LES	QUANTITIES
DESIGN CK.	LRRI	DETAIL CK.	LRRI	QUAN. CK.
			APP'D	Terry L. Fleck
			LES	GFK