

BENCHMARK:
 BM #2 - Chiseled "□" on the Top of Curb at the West End of the Northwest Curb Return of 11th Street North and Estelle Avenue.
 Elevation = 1312.12 (NAVD 88)

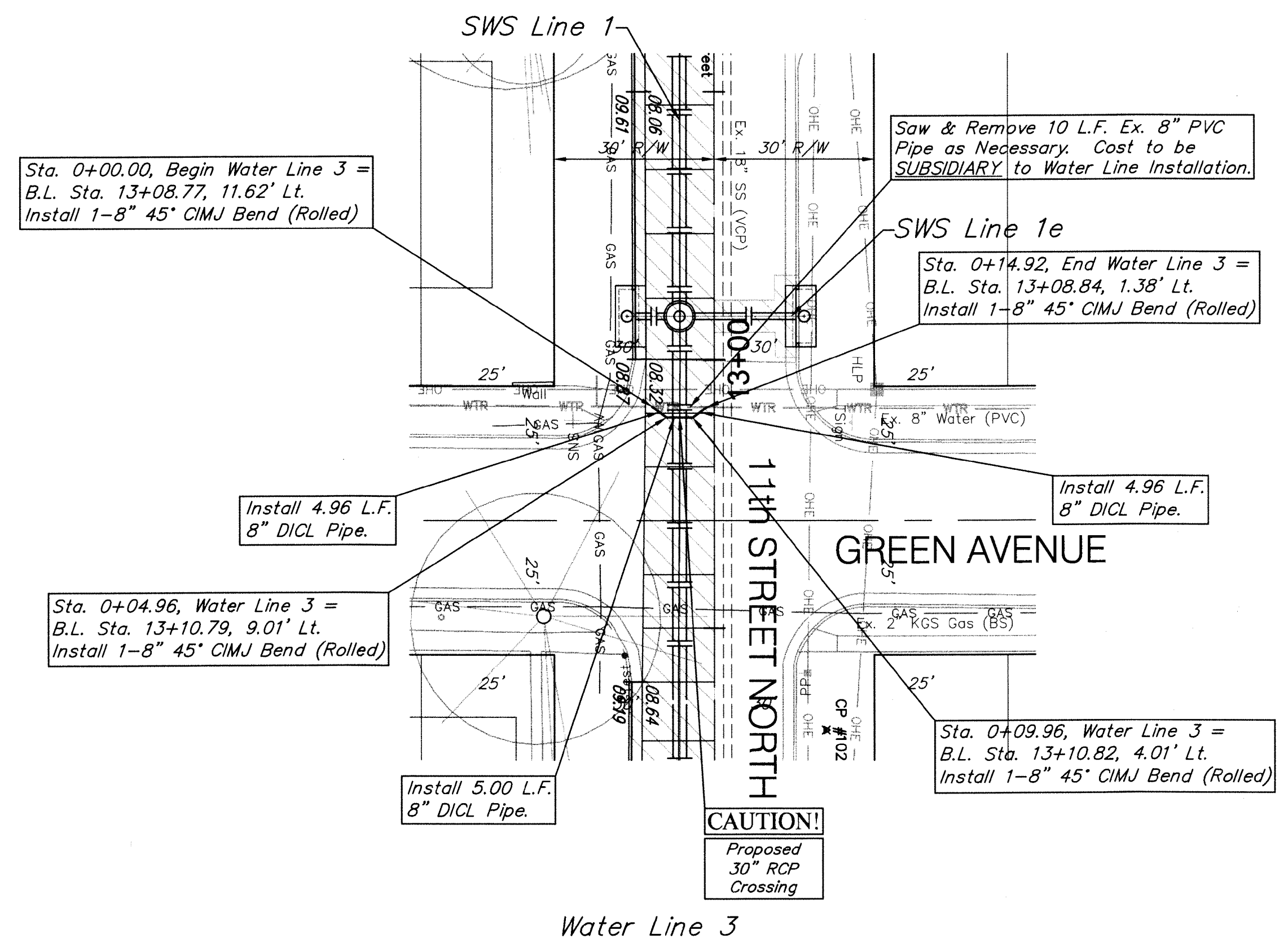

Water Line 3

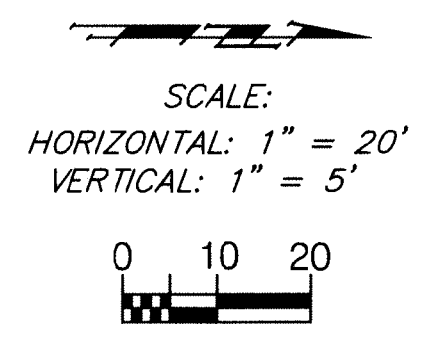
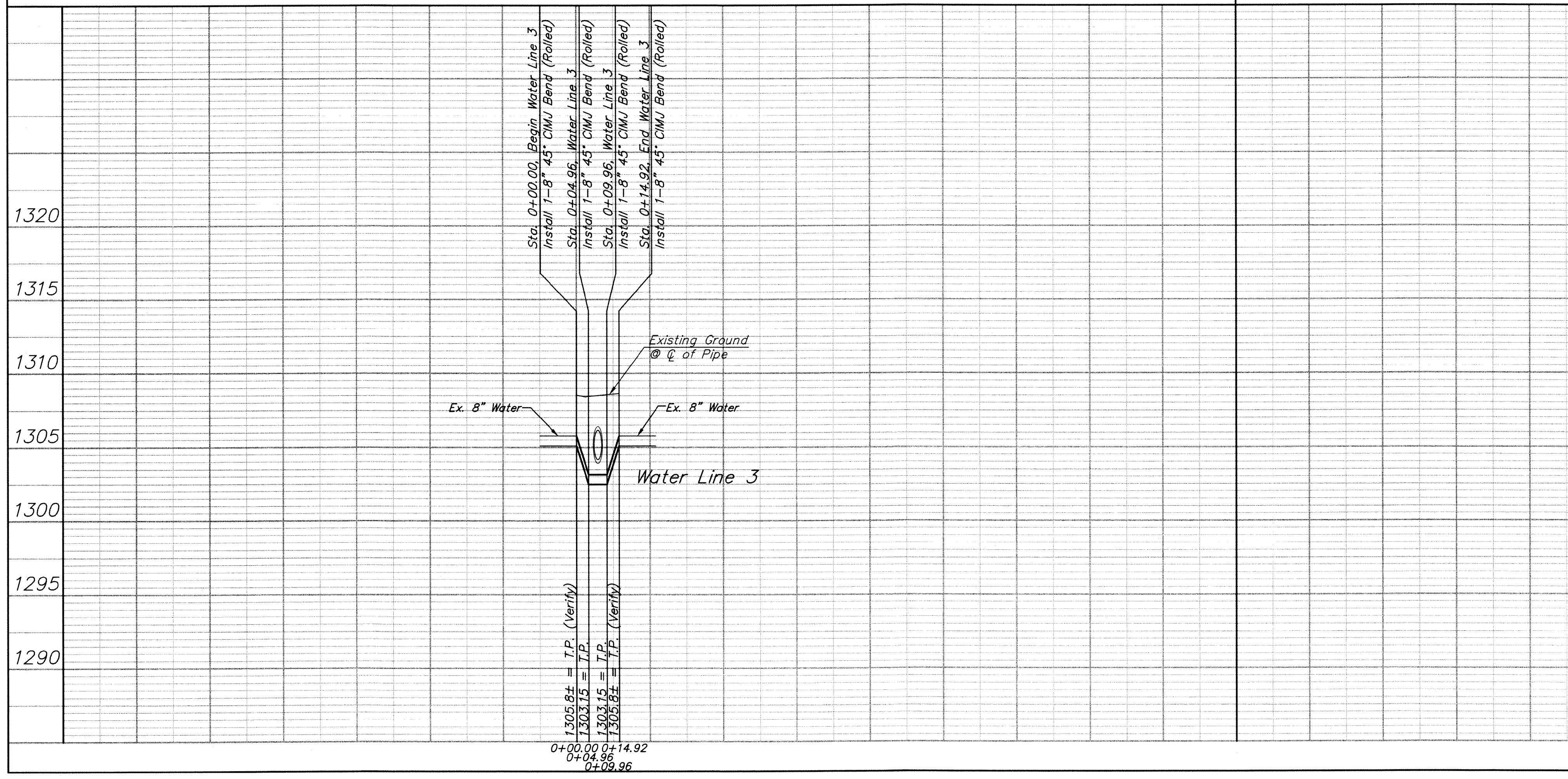

BENCHMARK:
 BM #2 - Chiseled "□" on the Top of Curb at the West End of the Northwest Curb Return of 11th Street North and Estelle Avenue.
 Elevation = 1312.12 (NAVD 88)

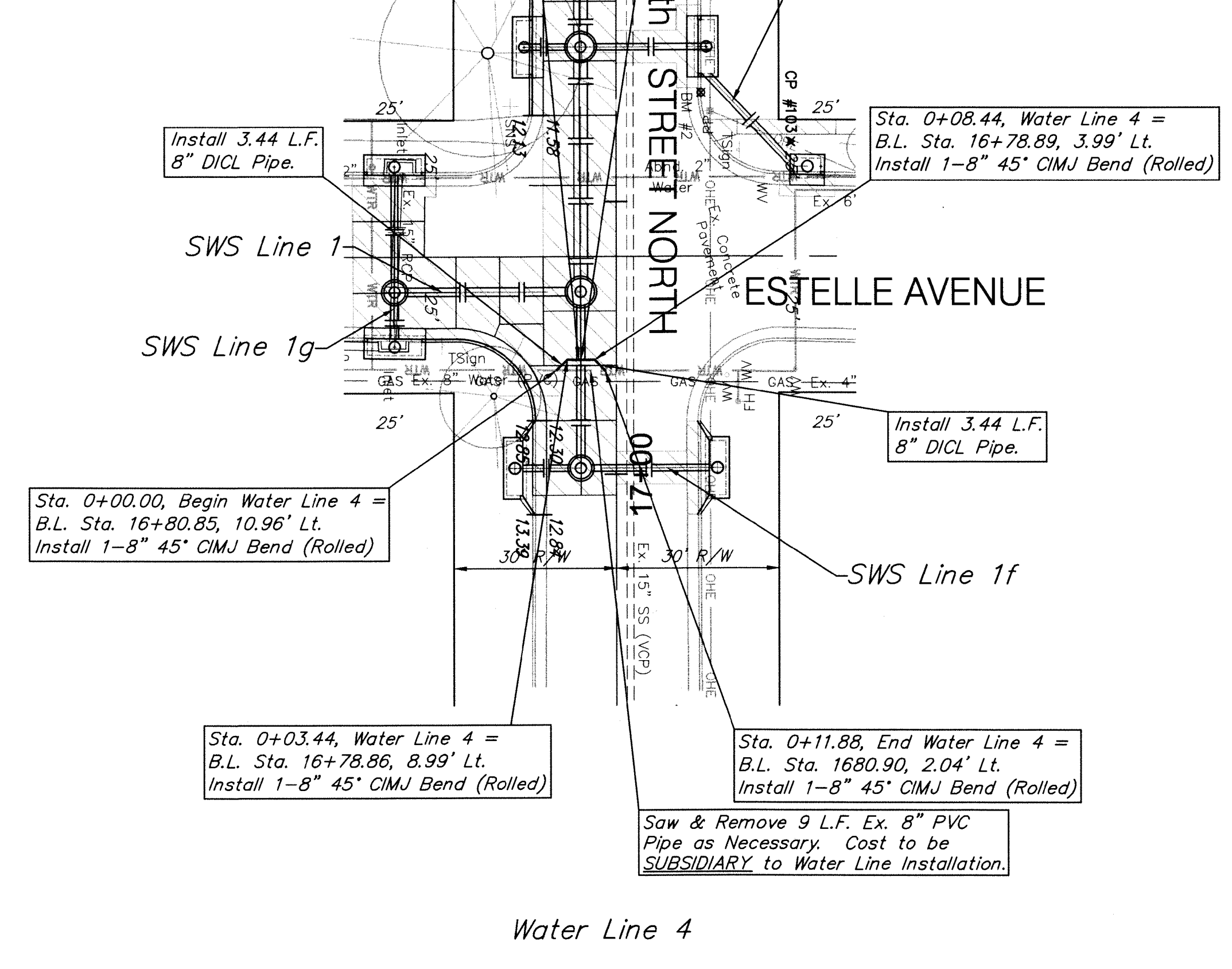
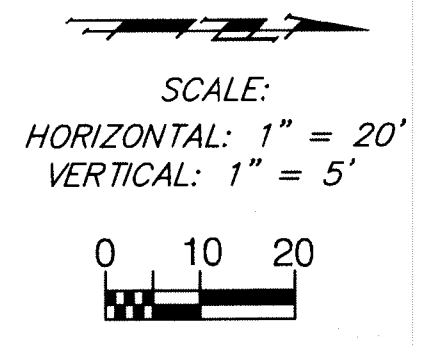

Water Line 4

