

KEYWAY DETAIL

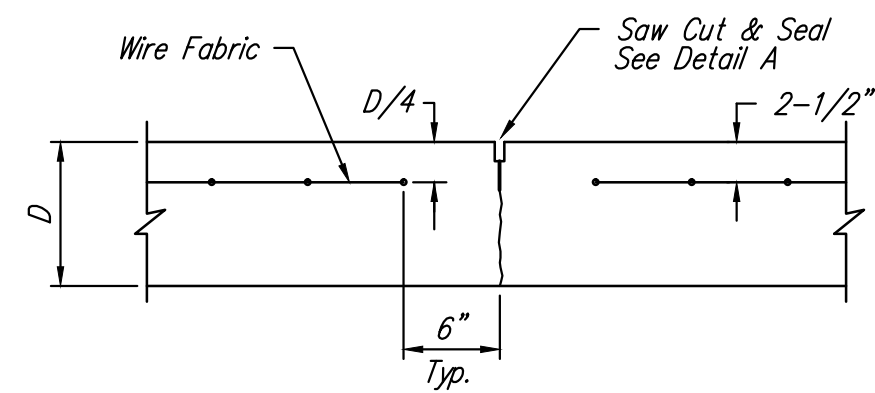

CONTRACTION JOINT DETAIL (C.J.)

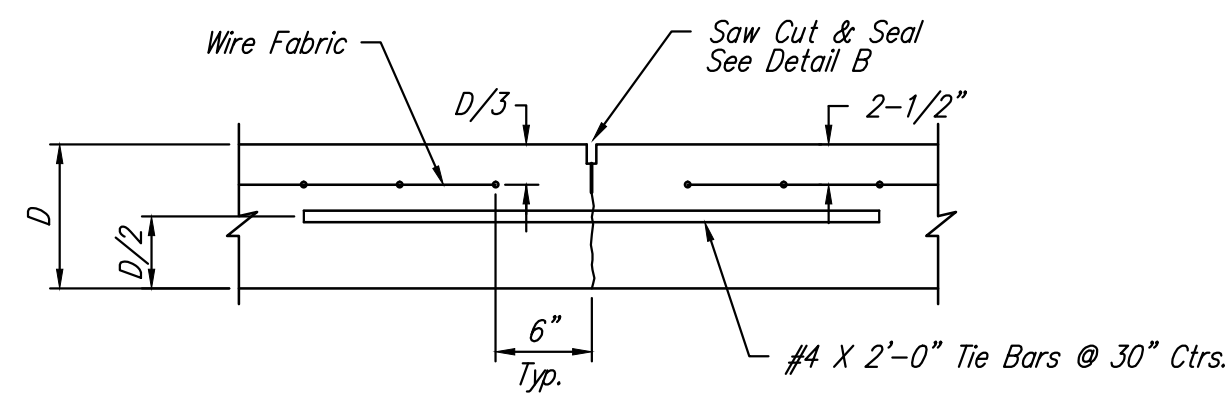

LONGITUDINAL JOINT DETAIL (L.J.)

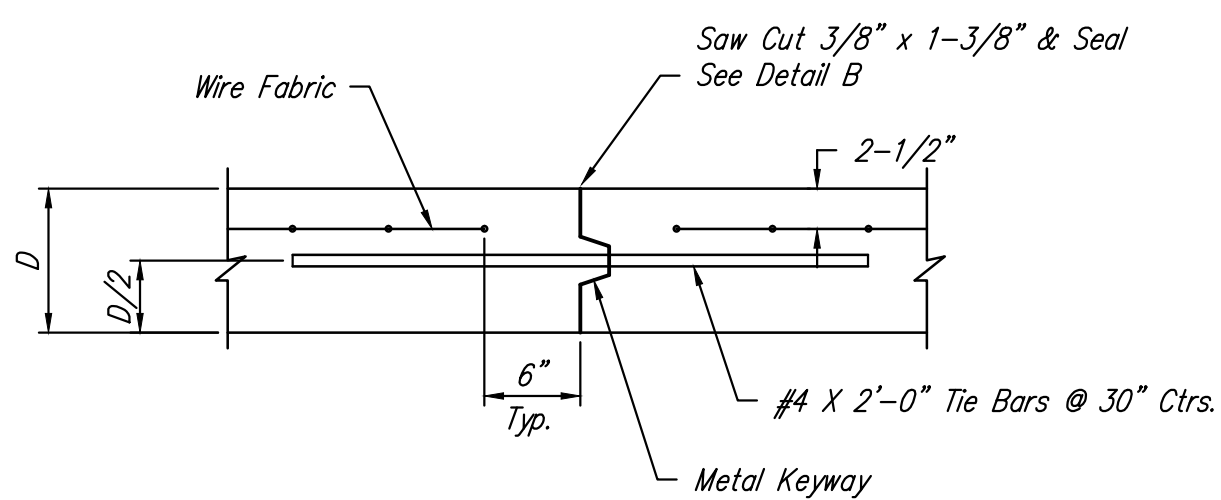

OPTIONAL LONGITUDINAL JOINT DETAIL (L.J.) (CONSTRUCTION JOINT)

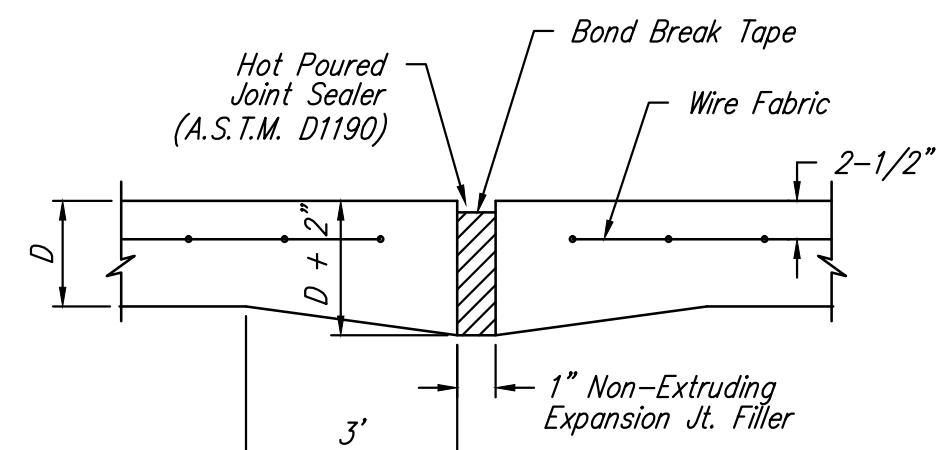

EXPANSION JOINT

NOTE: Extra Thickness to be Subsidiary to Price of Square Yards Pavement

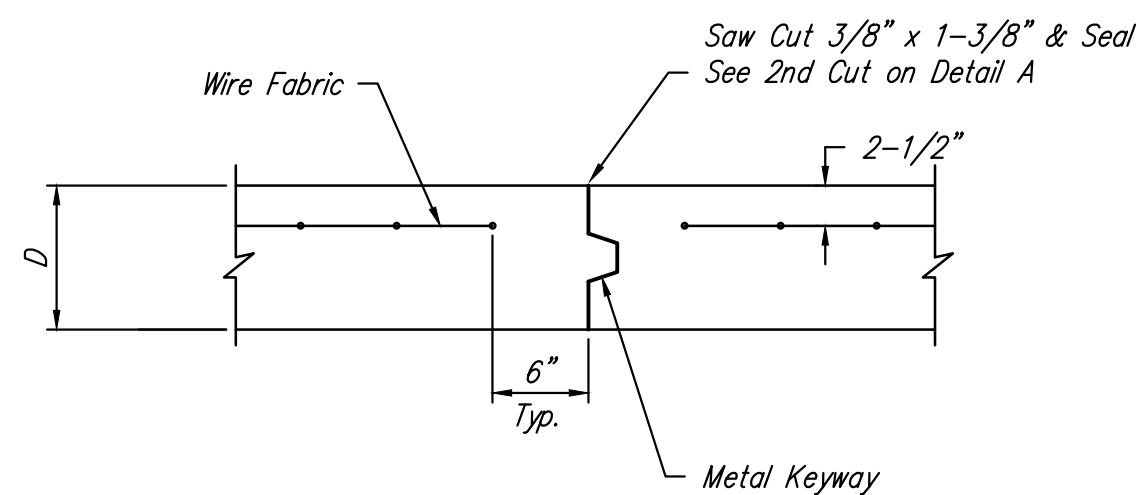

OPTIONAL CONTRACTION JOINT (CONSTRUCTION JOINT)

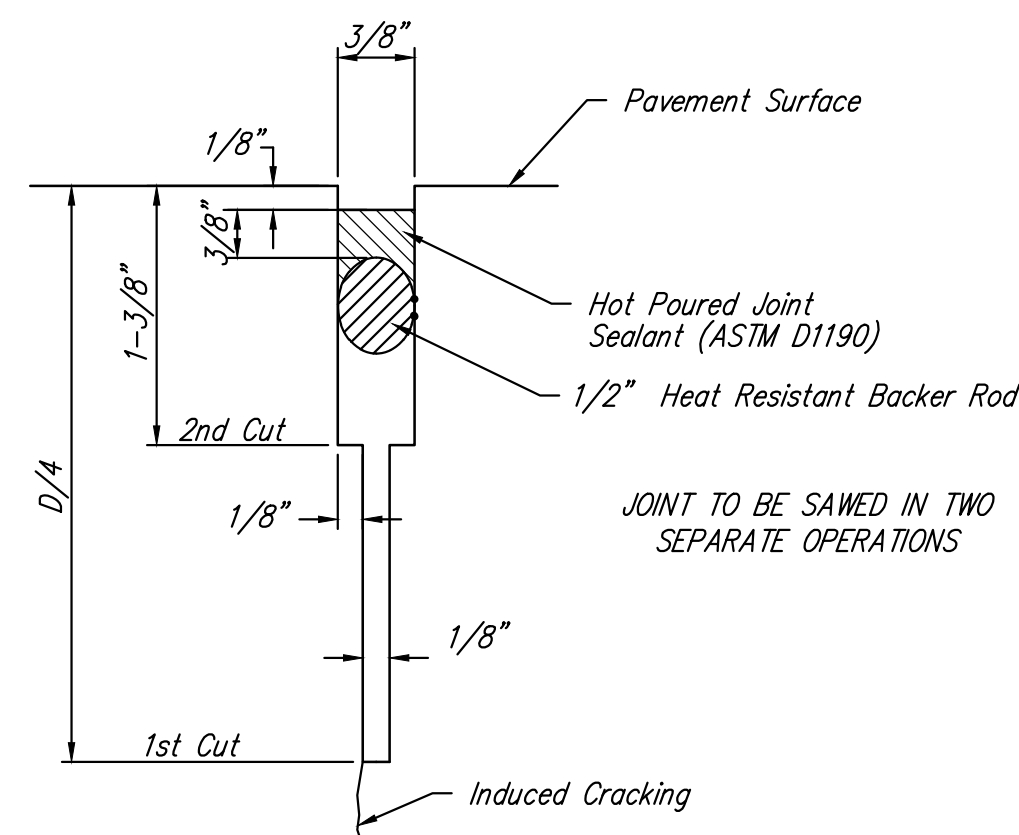

SAW JOINT DETAIL "A"

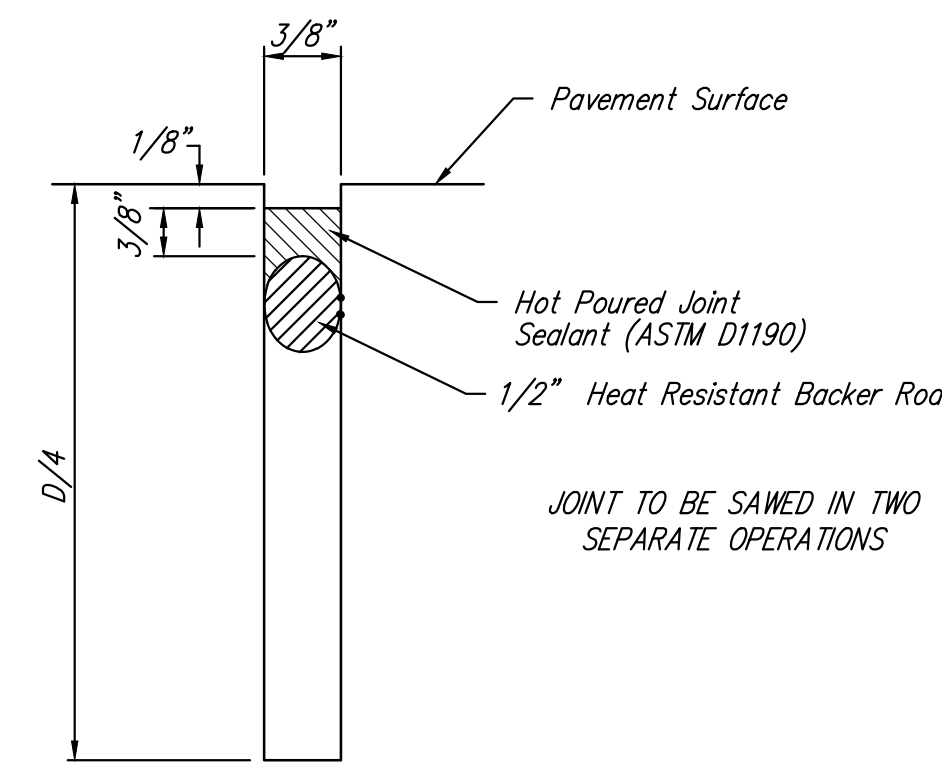

SAW JOINT DETAIL "B"

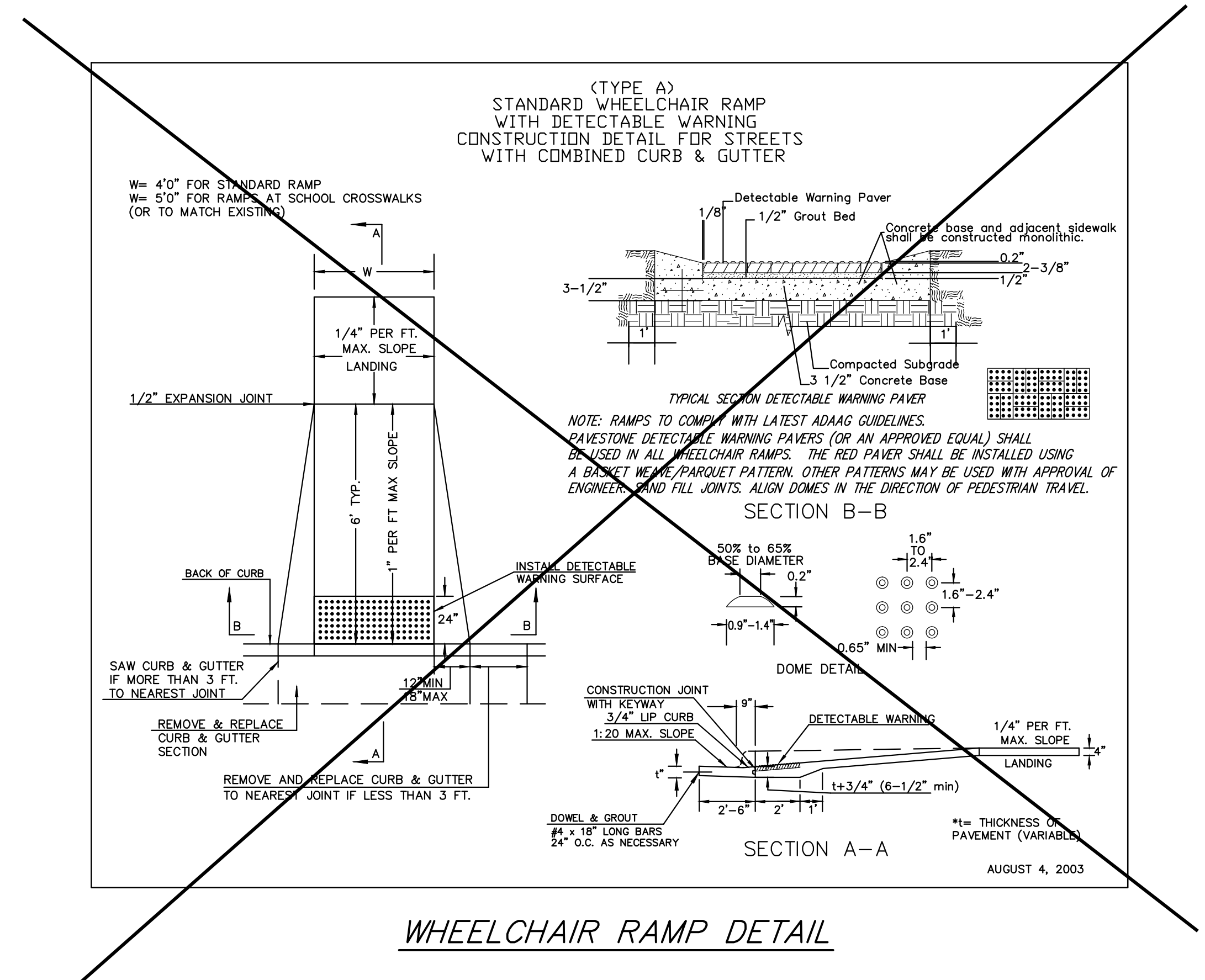

WHEELCHAIR RAMP DETAIL

	Liberty Park 3rd Addition - Phase 2B VALLEY GUTTER & MISCELLANEOUS DETAILS City of Wichita, Kansas	
	Baughman Company, P.A. 315 Ellis St. Wichita, KS 67211 P 316-262-7271 F 316-262-0149 ENGINEERING SURVEYING PLANNING LANDSCAPE ARCHITECTURE	
PROJECT NUMBER 472-84069	DESIGN JAK	DRAWN JAK
REVISIONS:	APPROVED	DATE 7/11
	SCALE NONE	SHEET 4 OF 24