

STATE	PROJECT NO.	YEAR	SHEET NO.	TOTAL SHEETS
KANSAS	472-85080	2013	C21	

Note: Designer to add applicable dowel sizes.

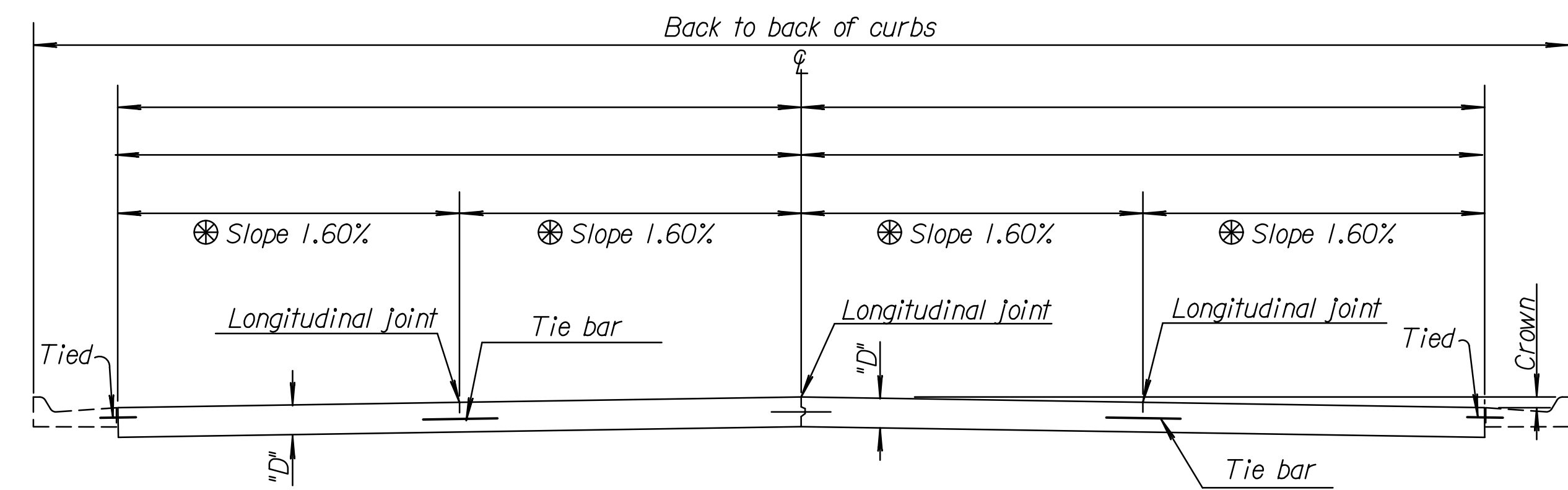

For Curb & Gutter details
See Standard Drawing RD635.

TRANSVERSE SECTION
(4 - LANE WITH CURB & GUTTER)

⊗ Normal cross slopes. See Typical Section or Cross Sections for variations.

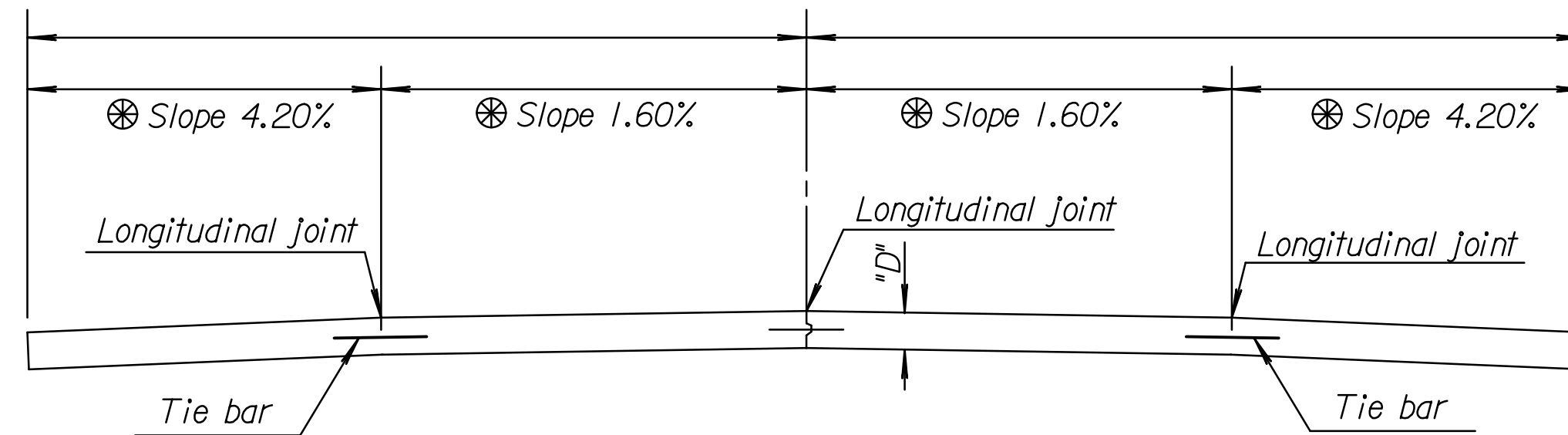

TRANSVERSE SECTION
(2 - LANE WITH SHOULDERS)

GENERAL NOTE

Epoxy coat all deformed tie bars. Patch any damage to the epoxy coating in accordance with the Standard Specifications.
Use billet steel Grade 40 reinforcing for deformed tie bars that require bending, may or may not be epoxy coated.
Place pressure relief joint at the end of the bridge approach pavement slab (no bars through joint). For details of pressure relief joint see Standard Drawing RD712.
Use load transfer devices as shown in details at all construction joints on mainline pavement unless otherwise noted. Shoulder contraction joints have no dowels unless specifically shown on the plans.
Fill all sawed joints on the project in accordance with the Standard Specifications with the exception of those joints in pavement constructed over Cement or Asphalt Treated Base.
Use single saw cut, 1/8" wide, joint in pavement constructed over Cement or Asphalt Treated Base (Non-Sealed Contraction Joint Sawcut). See detail this sheet.
Shape all keyed joints similar to section of recessed form leg as shown on this sheet.
Evenly space tie bars along the length of slab with no tie bar within 12" of contraction joint. All longitudinal joints are tied.
Shoulder rumble strips will not be constructed as part of this project.

DOWEL SIZE	
D (in.)	Diameter
6 < D < 9	1"
9 ≤ D < 11	1 1/4"
D ≥ 11	1 1/2"

PAVEMENT DEPTH

D =

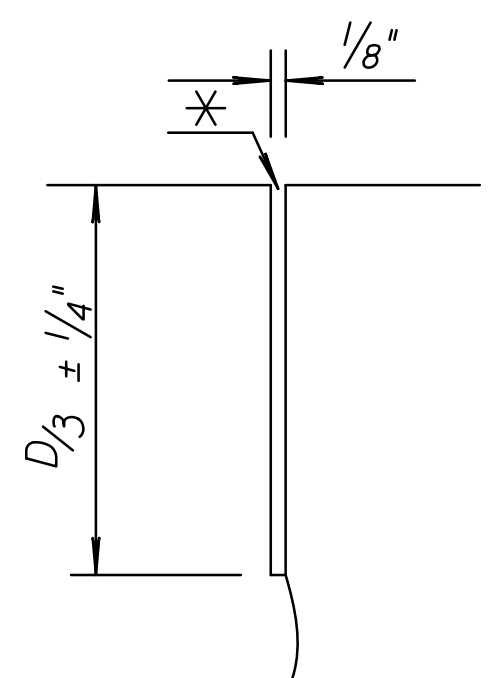

DETAIL OF NON-SEALED CONTRACTION JOINT SAWCUT

Make only the initial 1/8" saw cut after concrete has gained sufficient strength to avoid spalling as determined by the Engineer.

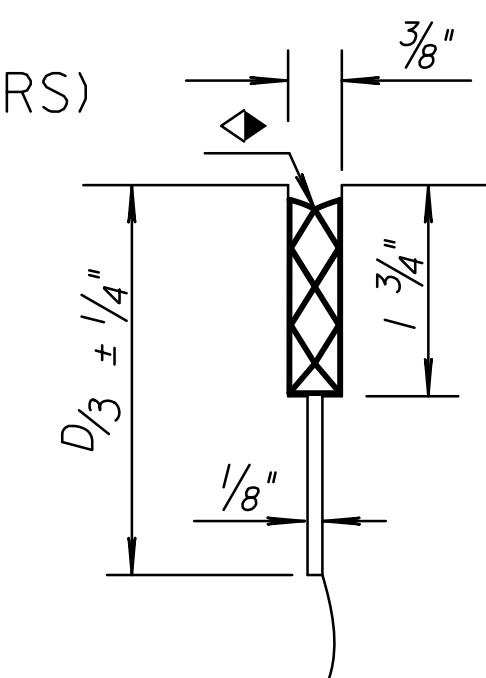

DETAIL OF SEALED CONTRACTION JOINT SAWCUT

Make an initial 1/8" saw cut (D/3 ± 1/4" depth); the second 3/8" saw cut is a separate operation done after concrete has gained sufficient strength to avoid spalling as determined by the Engineer.

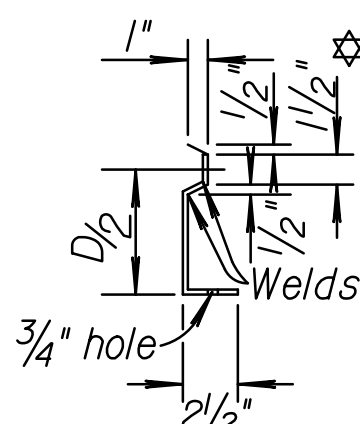

SECTION OF RECESSED FORM LEG

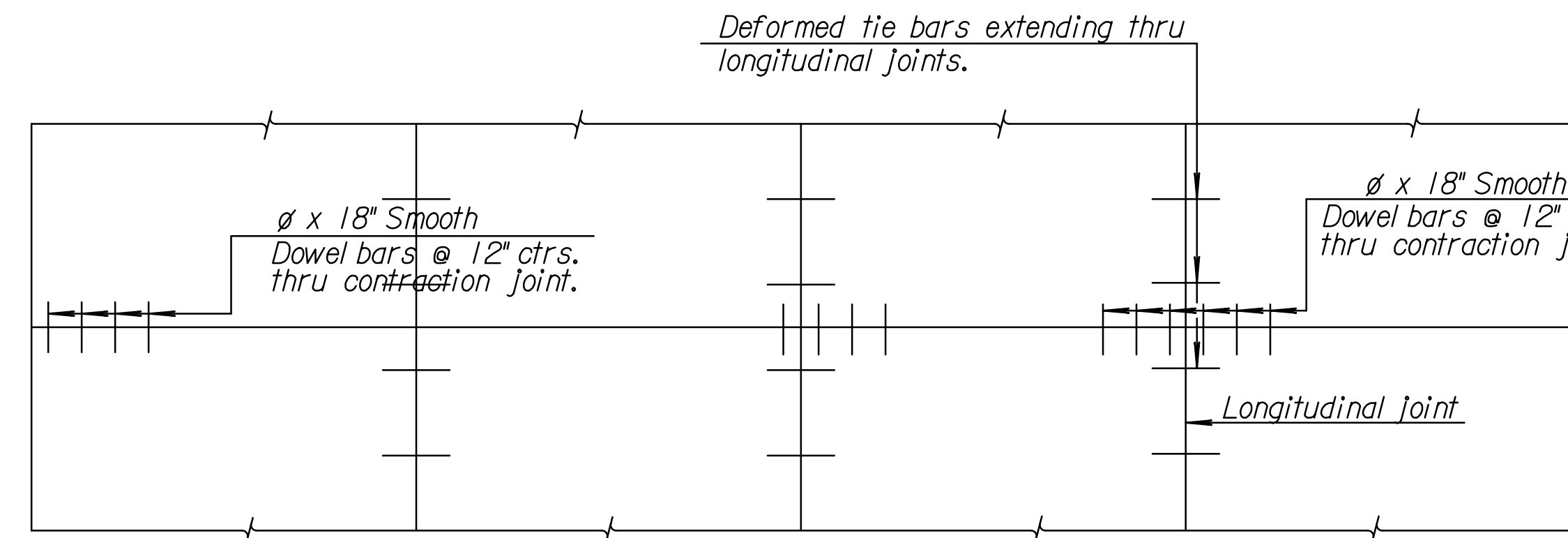

PLAN
(4 - LANE WITH CURB & GUTTER)

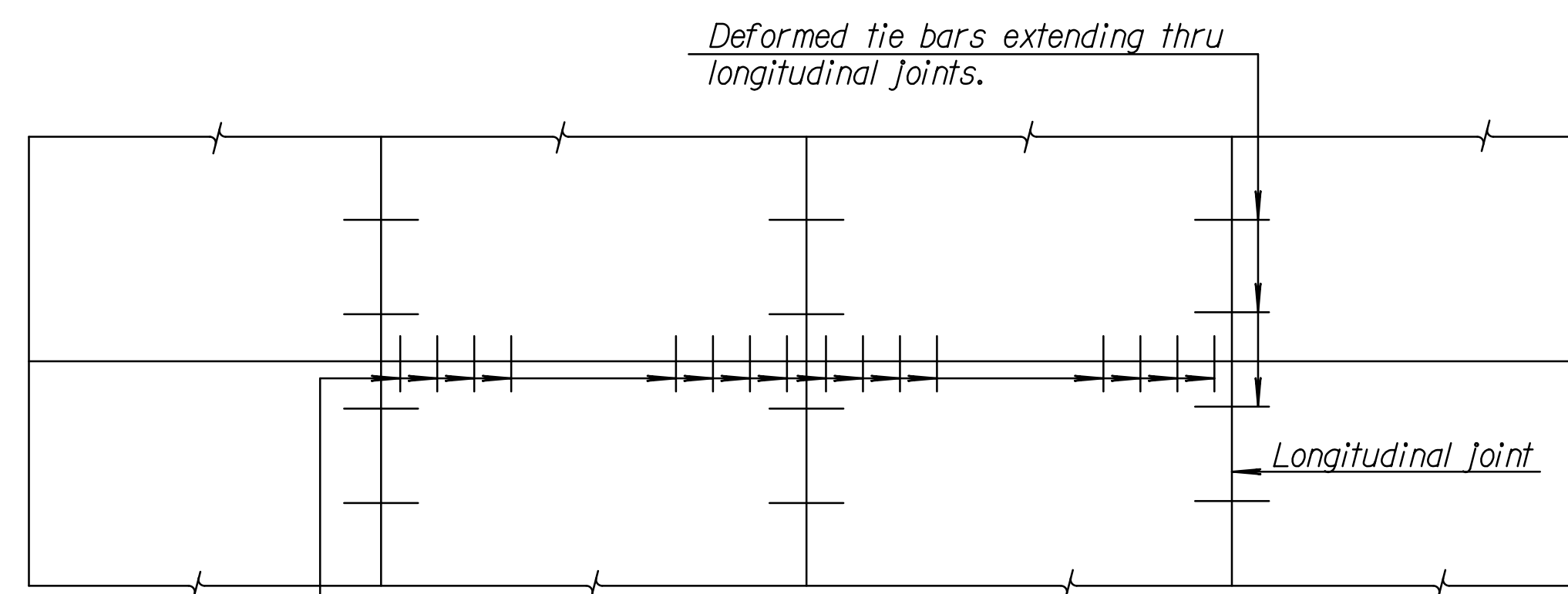

PLAN
(2 - LANE WITH SHOULDERS)

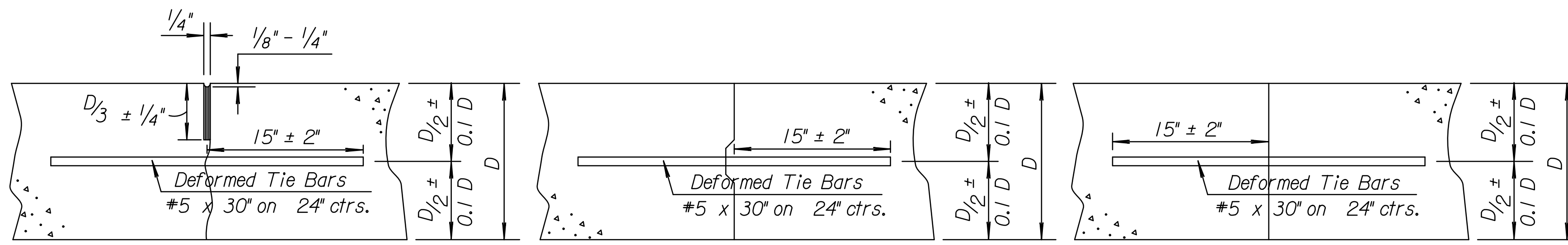

Tied Non-Keyed Tied Keyed Construction Tied Butt Construction

Note: For longitudinal construction joints the contractor has the option of using either the keyed or butt type.

LONGITUDINAL JOINTS

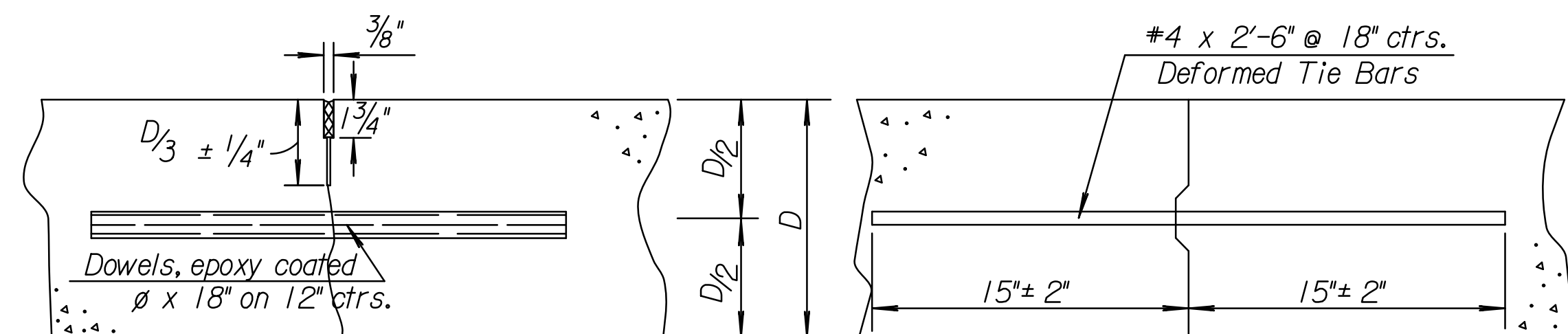

Contraction

Construction

TRANSVERSE JOINTS

Note: Construct contraction joints at plan locations or at the Engineer's direction.

When necessary to interrupt continuous placement for a substantial length of time or at the end of a day's paving, the Contractor has the option of ending placement at a contraction joint or with a construction joint located a minimum of five (5) feet from a contraction joint. Construct either joint type by placing a header at the end of the pour or by paving past the joint location. After the concrete has hardened, saw joint and drill holes for tie bars or dowels.

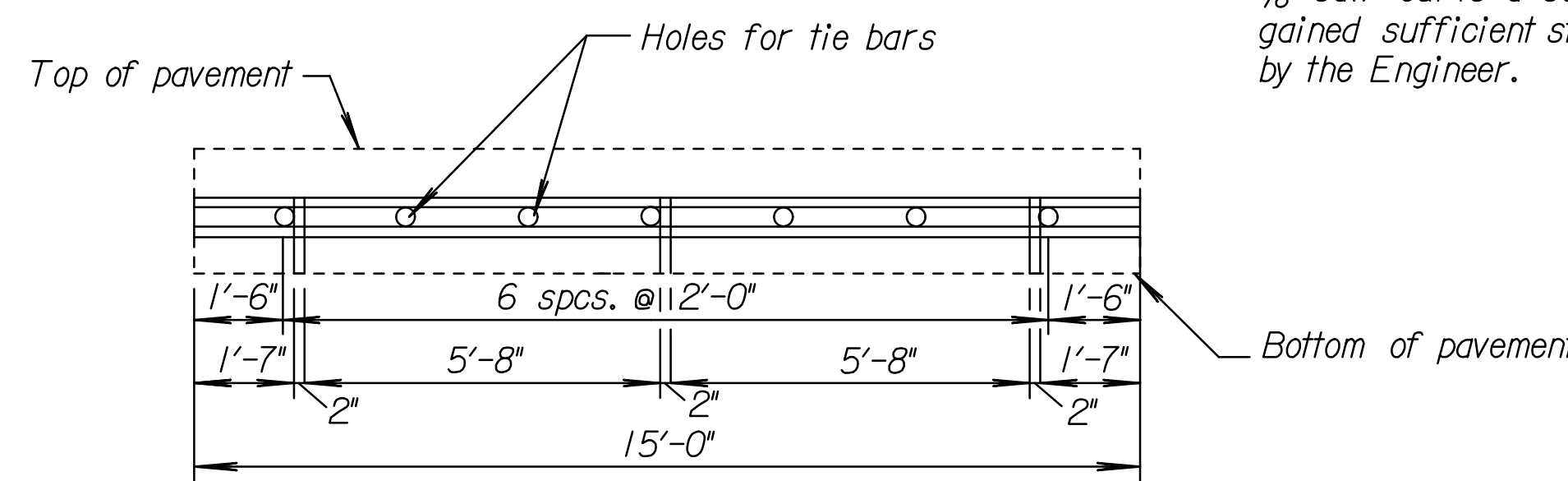

METAL STRIP FOR LONGITUDINAL CONSTRUCTION JOINT

To be used only against forms, do not extend through contraction joints.
For automated placement tie bars are spaced at uniform 24" centers.
Use snap-in leg or other approved design in lieu of welded leg.

NO.	DATE	REVISIONS	BY	APP'D
18	3-21-12	Revised Table, Dowel Size	S.W.K.	J.O.B.
17	1-9-12	Added Detail, Non Sealed Joint	S.W.K.	J.O.B.
16	8-18-10	Revised Dowel Size & Notes	S.W.K.	J.O.B.

KANSAS DEPARTMENT OF TRANSPORTATION
CONCRETE PAVEMENT
DOWEL JOINTED
NON-REINFORCED

RD708		APP'D. James O. Brewer	
DESIGNED	4-13-12	QUANTITIES	TRACED Bowser
DESIGN CK.	DETAIL CK.	QUAN. CK.	TRACE CK. King

Drawn By: cp
Plotted: 18-DEC-2013 09:10
File: I:\2012\12738\FINAL PLANS\Standards\12738-rd708.dgn