

Use Keystone "No-Weld Number 1 Anti-Seize Compound" on all bolts & nuts.

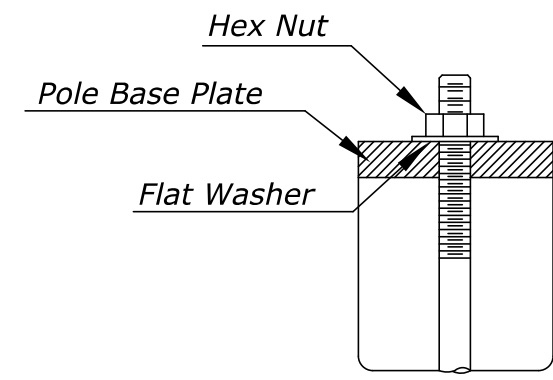

**ANCHOR BOLT
DETAIL**

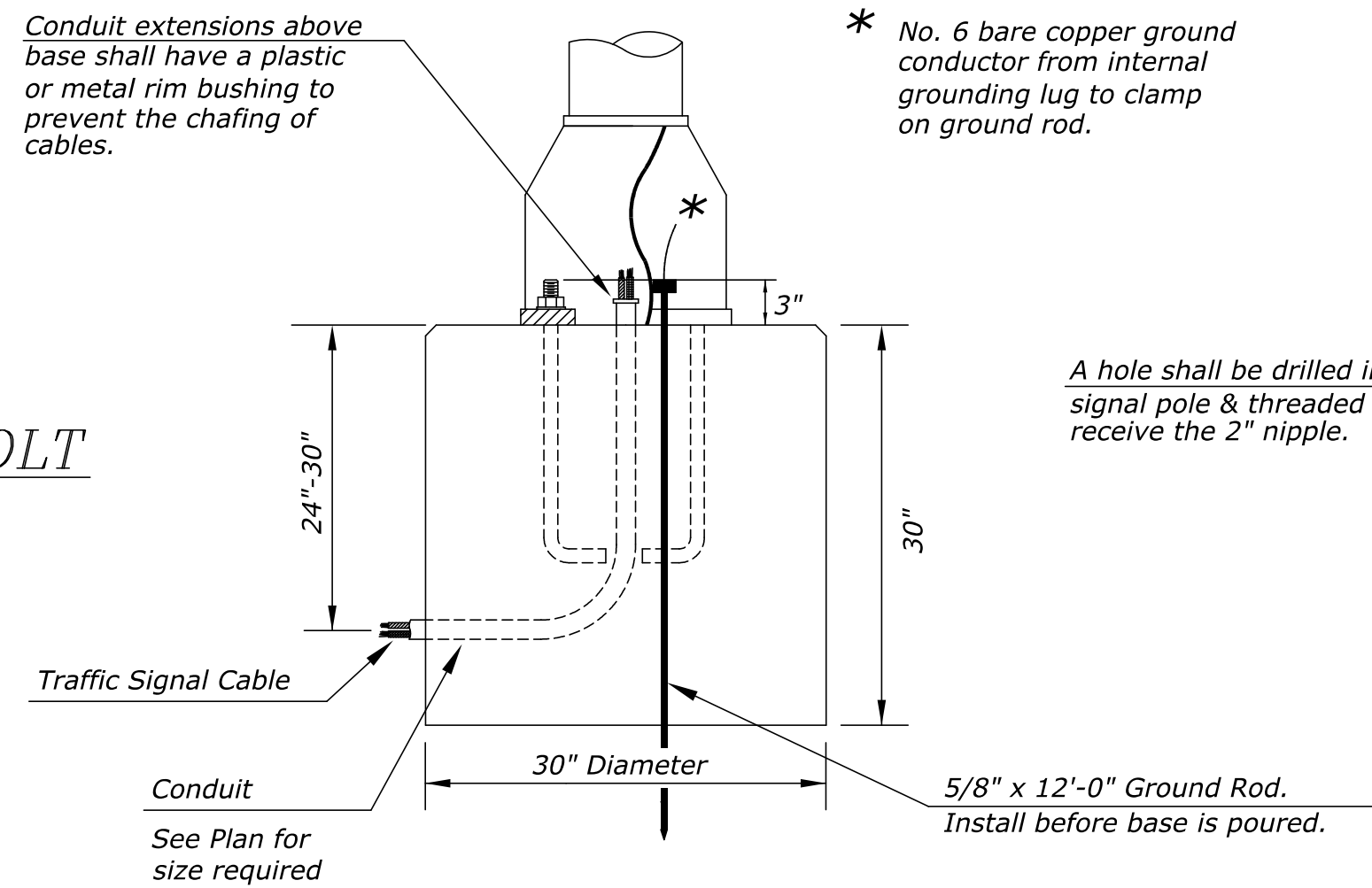

CONCRETE BASE DETAIL

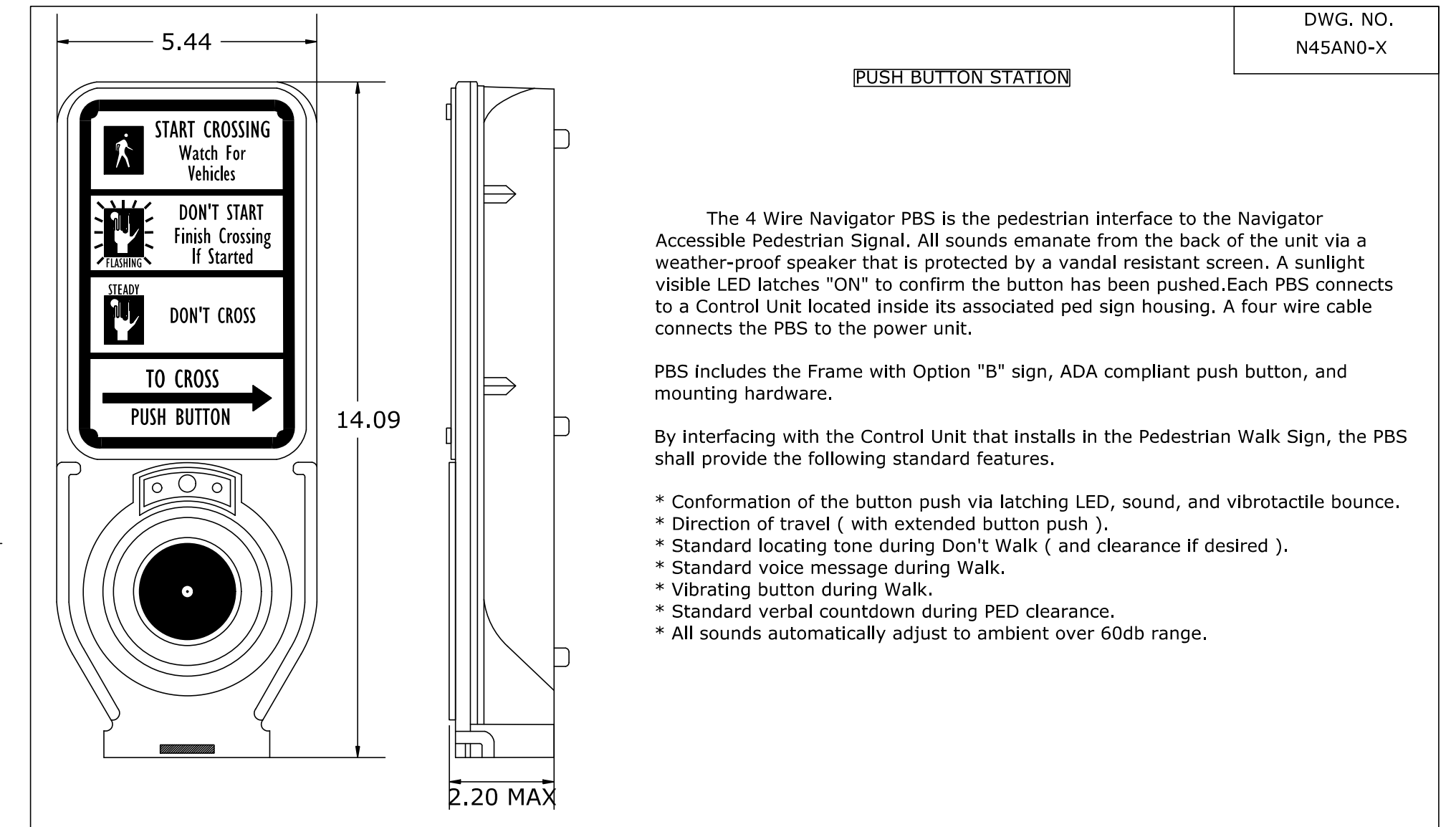
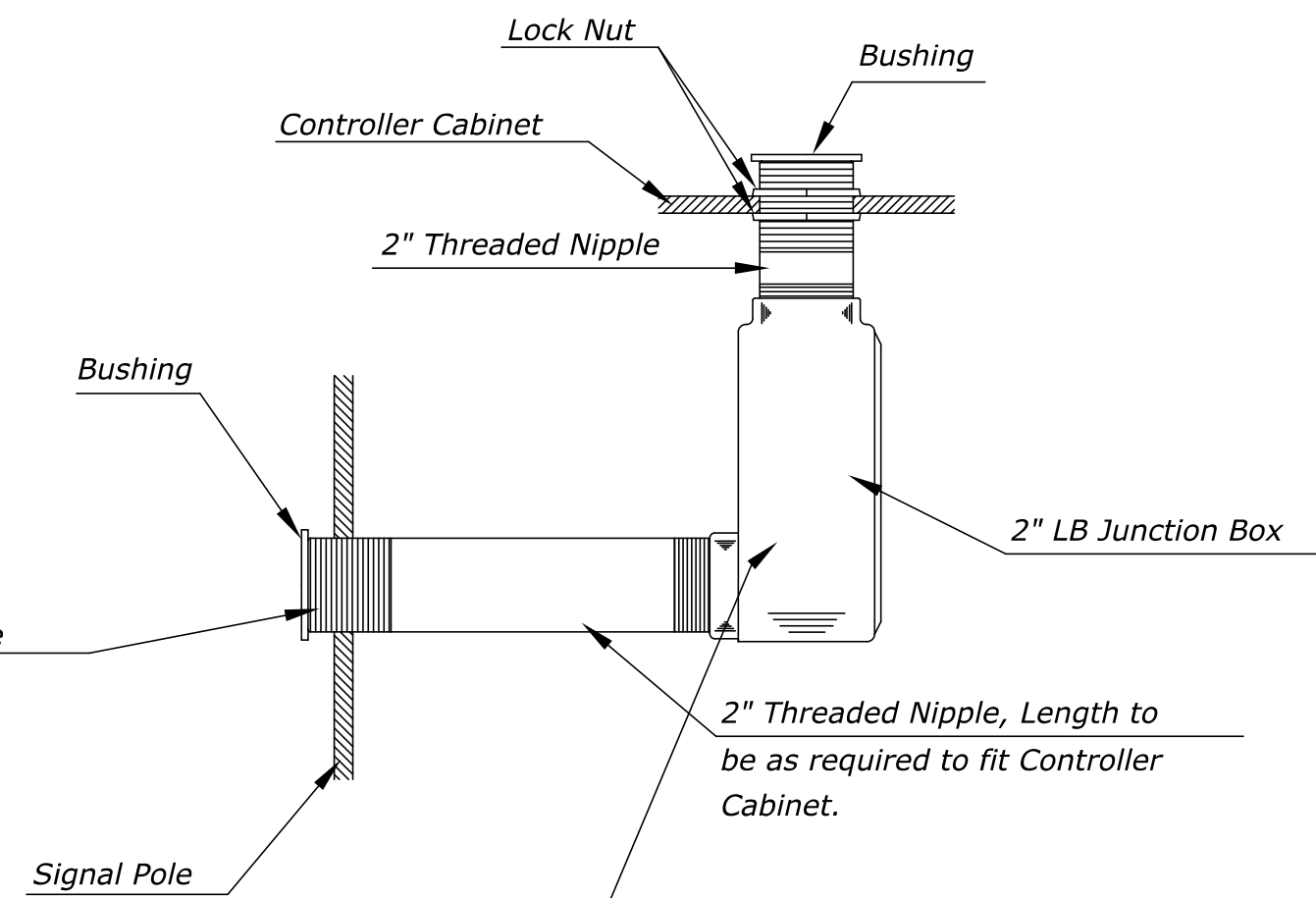

**PEDESTRIAN PUSHBUTTON/SIGN
UNIT DETAIL**

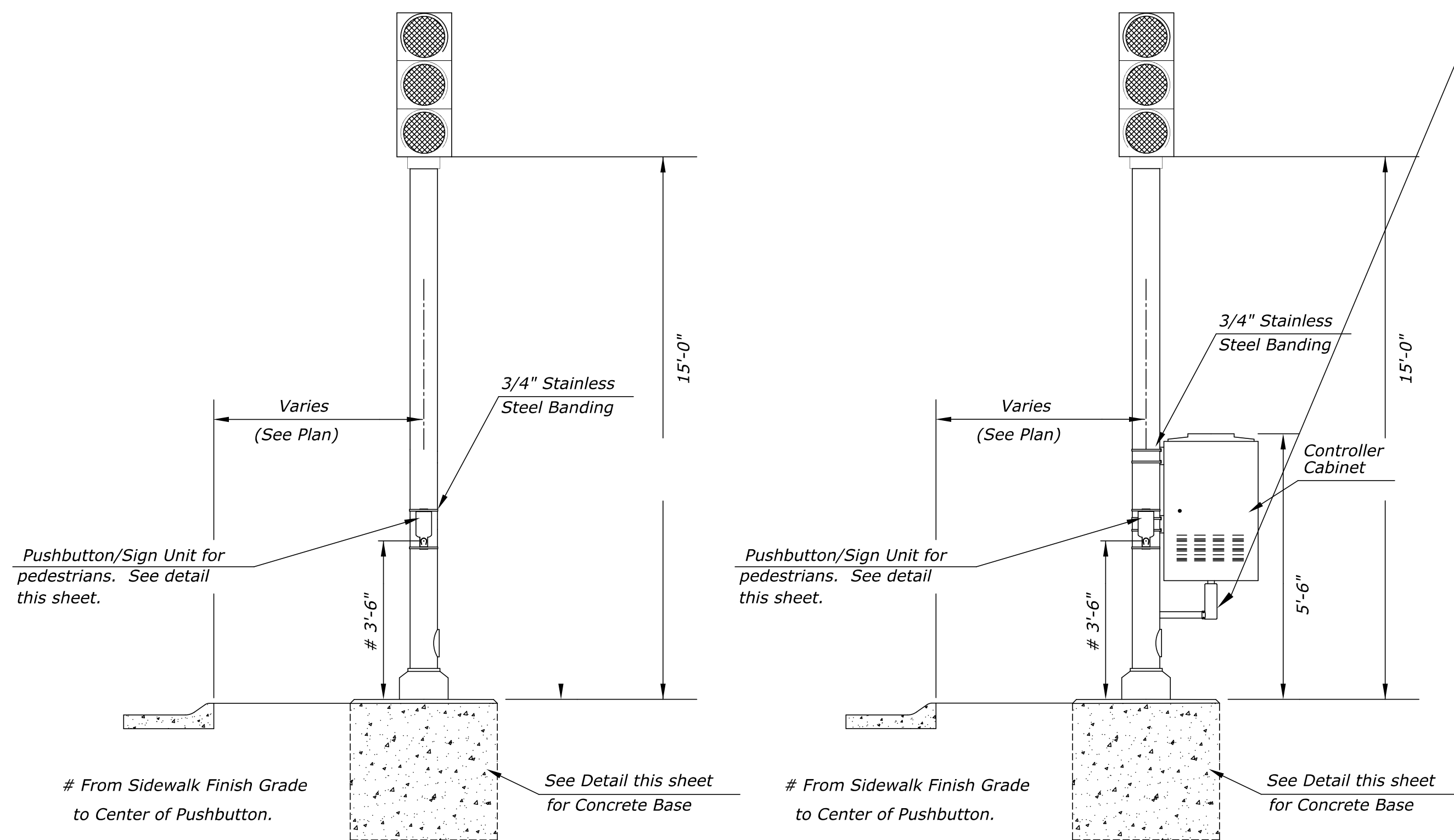

TRAFFIC SIGNAL PEDESTAL

**TRAFFIC SIGNAL PEDESTAL
WITH CONTROLLER CABINET**

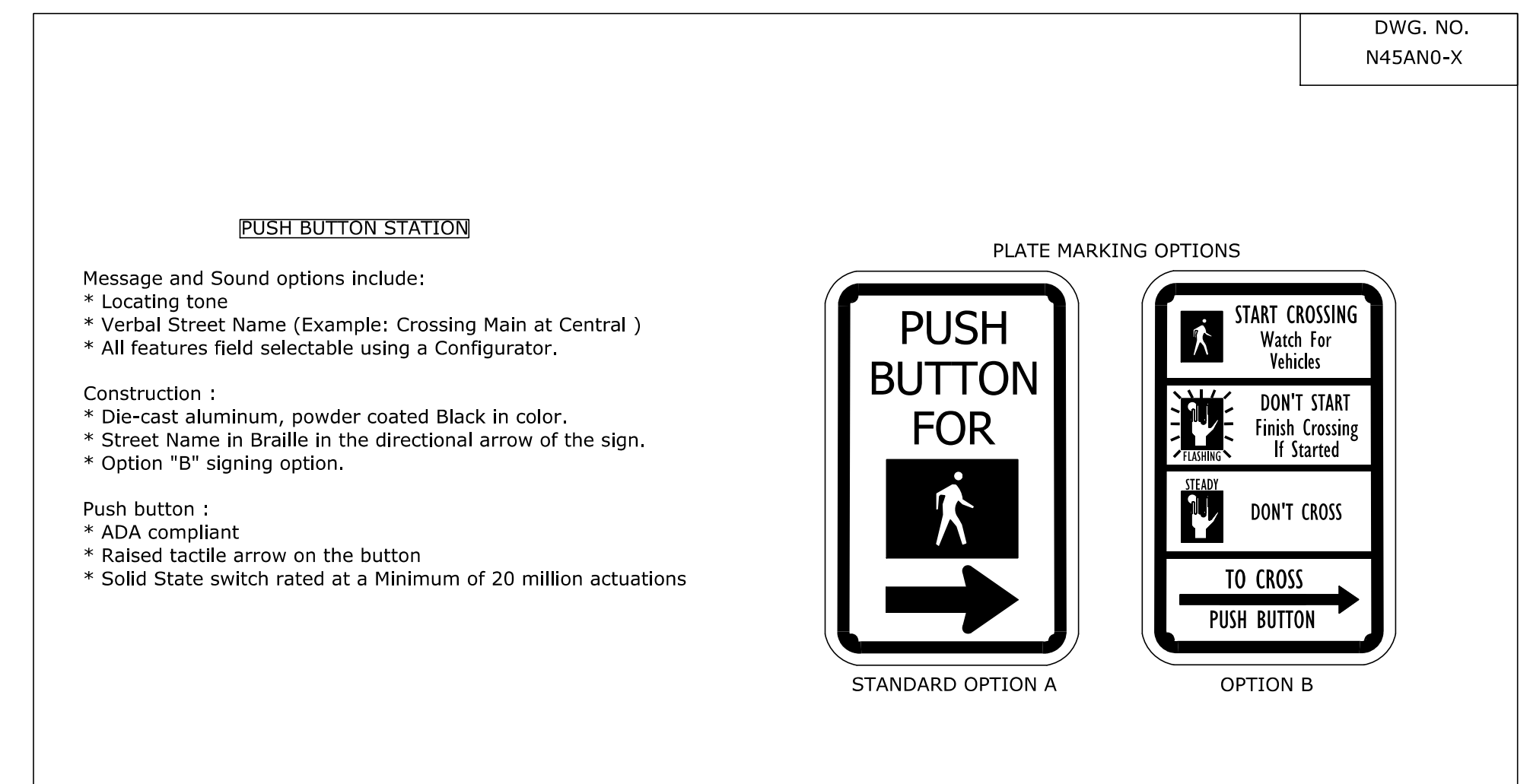

**SIGNAL PEDESTAL & BASE
WITH ADA PUSH BUTTON**

TRAFFIC ENGINEER BRIAN COON, P.E.		
PROJECT NUMBER 472-85174	OCA NUMBER 707074	DATE 10/2012
CITY ENGINEER'S OFFICE CITY HALL - SEVENTH FLOOR 455 NORTH MAIN STREET WICHITA, KANSAS 67202-1620 (316) 268-4501		SHEET 20 of 28