

SIGN LAYOUT INFORMATION

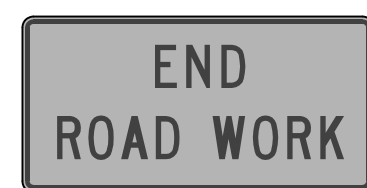

KG20-2

STD. SIZE
EXPWY/FREEWAY
6" C
48"x 24"



KG20-5

STD. SIZE
EXPWY/FREEWAY
6" C
48"x 24"



KM4-20

STD. SIZE
EXPWY/FREEWAY
3" C
24"x 6"

6" C
48"x 12"



W7-3a

MILEAGE TO BE DETERMINED BY THE ENGINEER.



W8-11

STD. SIZE
EXPWY/FREEWAY
8" D
48"x 48"



W8-17

STD. SIZE
EXPWY/FREEWAY
48"x 48"



W8-17P
(OPTIONAL)

STD. SIZE
EXPWY/FREEWAY
30"x 24"



SP-01
(SPECIAL SIGN)

STD. SIZE
EXPWY/FREEWAY
6" C
10" D

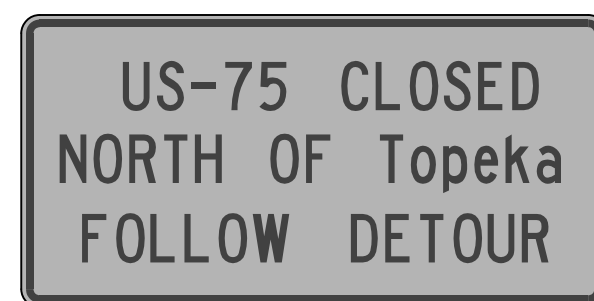

SP-02
(SPECIAL SIGN)

STD. SIZE
EXPWY/FREEWAY
UPPERCASE: 6" C
LOWER CASE: 4.5" C
UPPERCASE: 10" D
LOWER CASE: 8" D

ALL CITY NAMES AND STREET NAMES ON SPECIAL SIGNS AND DESTINATION SIGNS MUST HAVE UPPER AND LOWER CASE LETTERS.

ALL SIGNS SHALL BE BLACK ON ORANGE RETROREFLECTIVE SHEETING.

GENERAL NOTES

1. MAINTENANCE:

THE CONTRACTOR SHALL MAINTAIN ALL SIGNS AND DEVICES IN AN UPRIGHT POSITION. THE CONTRACTOR SHALL CLEAN OR REPLACE ANY DAMAGED OR ILLEGIBLE SIGN OR DEVICE AS DIRECTED BY THE ENGINEER.

2. EXISTING SIGNS:

IF EXISTING SIGNS THAT ARE TO REMAIN (WHETHER DENOTED ON THE PLANS OR NOT) INTERFERE WITH CONSTRUCTION WORK, THE CONTRACTOR SHALL REMOVE, STORE, AND RESET THE SIGNS. THIS SHALL BE SUBSIDIARY TO OTHER TRAFFIC CONTROL BID ITEMS. SIGNING DAMAGED BY THE CONTRACTOR SHALL BE REPLACED AT THE CONTRACTOR'S EXPENSE.

3. CONFLICTING SIGNS, SIGNS NOT IN USE, AND TRAFFIC SIGNALS:

SIGNS AND TRAFFIC SIGNALS THAT ARE IN CONFLICT WITH THE TRAFFIC CONTROL PLAN OR DO NOT APPLY TO THE TRAFFIC OPERATIONS SHALL BE IMMEDIATELY REMOVED, TURNED SO NOT VISIBLE TO TRAFFIC FROM ANY DIRECTION, OR COMPLETELY COVERED WITH ADEQUATE OPAQUE BREATHABLE MATERIAL. TAPE SHALL NOT BE APPLIED TO THE FACE OF THE SIGN.

4. PORTABLE AND POST MOUNTED SIGNS:

TEMPORARY TRAFFIC CONTROL SIGNS THAT ARE ANTICIPATED TO REMAIN IN PLACE FOR 3 DAYS OR LESS ARE CONSIDERED "PORTABLE." PORTABLE SIGNS SHALL BE MOUNTED ON AN APPROVED SUPPORT AT A MINIMUM HEIGHT OF 12" ABOVE THE TRAVELED WAY. TRAFFIC CONTROL SIGNS IN PLACE FOR OVER 3 DAYS ARE REQUIRED TO BE MOUNTED ON APPROVED POSTS. A MINIMUM OF 42" OF THE APPROVED POST MUST BE BELOW THE GROUND SURFACE WITH ADEQUATE BACKFILL AND COMPACTION. ALL POSTS AT MINIMUM SHALL EXTEND TO THE TOP EDGE OF THE SIGN AND NO GREATER THAN 6" ABOVE THE SIGN.

WHEN THE SIGN WIDTH IS EQUAL TO OR GREATER THAN 9', THREE OR MORE WOOD POSTS MAY BE USED WITH A MINIMUM OF 4' BETWEEN THE CENTERLINE OF EACH POST. ALL SIGNS LESS THAN 9' IN WIDTH SHALL USE A MAXIMUM OF TWO WOOD POSTS.

"ROLL-UP" SIGNS MAY BE USED FOR PORTABLE WARNING SIGNS. THEY MUST BE FLUORESCENT ORANGE ASTM TYPE IV SIGNS OF OPAQUE MATERIAL. MESH SIGNS ARE NOT ALLOWED.

IN THE CASE OF HITTING ROCK WHEN DRIVING POSTS

1. SHIFT THE SIGN LOCATION. DO NOT VIOLATE MINIMUM SIGN SPACING.
2. WITH THE ENGINEER'S APPROVAL, USE ACCEPTABLE ALTERNATIVE SIGN STANDS.

5. SHEETING:

ALL ORANGE SIGNS SHALL HAVE FLUORESCENT ORANGE ASTM TYPE IV SHEETING. ALL OTHER SIGNS SHALL HAVE ASTM TYPE III SHEETING OF STANDARD COLORS.

6. SIGNS INVOLVING SPEEDS:

THE W3-5 (SPEED REDUCTION) SHOULD BE USED ONLY IF THE ENGINEER DETERMINES THAT A REDUCED SPEED IS REQUIRED ON THE PROJECT.

THE KM4-20 (WORK ZONE) PLAQUE SHALL BE PLACED ABOVE ALL SPEED LIMIT SIGNS, (R2-1), EXISTING AND TEMPORARY. MOUNT THE WORK ZONE PLAQUES TO THE POST. DO NOT OVERLAP THE R2-1 AND KM4-20 SIGNS.

FOR SPEEDS OF 30 MPH OR LESS, THE W1-1(TURN) OR W1-3(REVERSE TURN) SHOULD BE USED. FOR SPEEDS OF 35 MPH OR MORE, THE W1-2(CURVE) OR W1-4(REVERSE CURVE) SHOULD BE USED. THE W13-1(MPH) IS TO BE ELIMINATED IF THE ADVISORY SPEED IS WITHIN 5 MPH OF THE SPEED LIMIT.

7. SIGNS CONTROLLING WORK ZONE:

THE KG20-2(END ROAD WORK) SHOULD BE PLACED 500' FROM THE END OF THE ACTUAL WORK SPACE, NOT NECESSARILY AT THE EXTREME LIMITS OF THE PROJECT. THE KG20-2 SHOULD BE MOUNTED ON TWO POSTS. THE KG20-2 MAY BE MOUNTED ON ONE POST IF IN URBAN AREAS WHERE UTILITIES ARE A PROBLEM AND WIND LOADS ARE NOT AN ISSUE.

WHERE TWO WORK ZONES ARE LESS THAN 1 MILE APART IN RURAL AREAS OR ¼ MILE APART IN URBAN AREAS, THE KG20-2(END ROAD WORK) FOR THE FIRST WORK ZONE AND THE W20-1(ROAD WORK) FOR THE SECOND WORK ZONE SHOULD BE ELIMINATED.

8. WARNING LIGHTS ON SIGNS:

A TYPE "A" LOW INTENSITY WARNING LIGHT IS AN L.E.D. BI-DIRECTIONAL FLASHING WORK ZONE WARNING LIGHT. TYPE "A" LOW INTENSITY WARNING LIGHTS SHOULD BE USED WITH ALL CONSTRUCTION ACTION WARNING SIGNS AND SHALL NOT BE USED ON SIGNS MOUNTED LESS THAN 5' HIGH ON TEMPORARY SUPPORTS. ON ALL OTHER CONSTRUCTION WARNING SIGNS, TYPE "A" LOW INTENSITY WARNING LIGHTS ARE TO BE USED AS DIRECTED BY THE ENGINEER.

TYPE "A" LOW INTENSITY WARNING LIGHTS SHALL BE MAINTAINED SO AS TO BE CAPABLE OF BEING VISIBLE ON A CLEAR NIGHT FROM A DISTANCE OF 3000 FT. IF A TYPE "A" LOW INTENSITY WARNING LIGHT HAS A SEPARATE BATTERY CASE, THE BATTERY CASE SHALL BE MOUNTED NO HIGHER THAN 12" ABOVE THE GROUND AND MOUNTED BEHIND THE SIGN POST. A TYPE "A" LOW INTENSITY WARNING LIGHT WHERE THE LENS AND BATTERY ARE ONE UNIT SHALL BE MOUNTED ON THE TEMPORARY SIGN POST NEAREST TO THE TRAVELED WAY. FLAGS SHALL NOT INTERFERE WITH THE VISABILITY OF THE TYPE "A" LOW INTENSITY WARNING LIGHT.

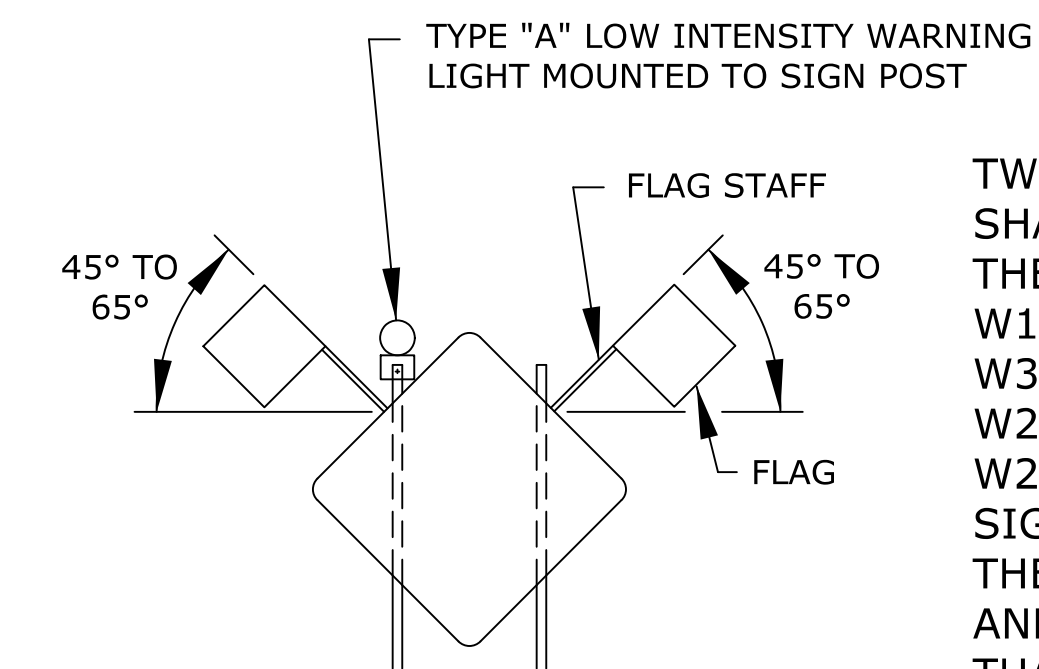

TWO (2) 18" x 18" FLUORESCENT RED-ORANGE FLAGS SHALL BE ATTACHED (IN THE POSITION SHOWN) ON THE W20-2(DETOUR), W1-1(TURN), W1-2(CURVE), W1-3(REVERSE TURN), W1-4(REVERSE CURVE), W3-3(SIGNAL AHEAD), W4-2(LANE REDUCTION), W20-4(ONE LANE ROAD), W20-5(LANE CLOSED), W20-7A(FLAGGER), AND W3-4 (BE PREPARED TO STOP) SIGNS AND ANY OTHER ACTION SIGNS AS SHOWN ON THE PLANS OR DIRECTED BY THE ENGINEER. THE FLAGS AND STAFFS ARE TO BE ATTACHED IN SUCH A MANNER THAT THE SIGN WILL NOT BE OBSCURED. THE FLAGS MAY BE EITHER A CLOTH OR VINYL MATERIAL. THE FLAGS SHALL BE SUBSIDIARY TO THE CONSTRUCTION SIGN BID ITEMS.

MINIMUM ADVANCE WARNING SIGN SPACING (IN FEET):

	A	B	C
URBAN (40 MPH OR LOWER)	100	100	100
URBAN (45 MPH OR HIGHER)	350	350	350
RURAL (55 MPH OR LOWER)	500	500	500
RURAL (60 MPH OR HIGHER)	750	750	750
EXPRESSWAY/FREEWAY	1000	1500	2640

THE MINIMUM SPACING BETWEEN SIGNS SHALL BE NO LESS THAN 100', UNLESS DIRECTED BY THE ENGINEER.

THE SPACING BETWEEN ANY SIGNS MAY BE INCREASED BEYOND THE MINIMUM VALUES IN THE TABLE ABOVE AS APPROVED BY THE ENGINEER IN ORDER TO MAXIMIZE VISIBILITY.

3	10/16/12	Removed Note 9, Modified Sign Layout Detail	J.A.M.	K.P.
2	10/4/11	Modified Note 3	J.A.M.	K.P.
1	2/24/10	Modified AFAD Note	J.A.M.	A.A.A.
NO.	DATE	REVISIONS	BY	APP'D

KANSAS DEPARTMENT OF TRANSPORTATION

TRAFFIC CONTROL SIGNS

TE710

FHWA APPROVAL	10/16/12	APP'D	Kristina Pyle
DESIGNED	B.A.H.	DETAILED	B.A.H.
DESIGN CK.	DETAIL CK.	QUANTITIES	TRACE CK.
		QUAN. CK.	TRACE CK.