

STATE	PROJECT NO.	YEAR	SHEET NO.	TOTAL SHEETS
KANSAS	87 TE-0620-01	2014	11	18

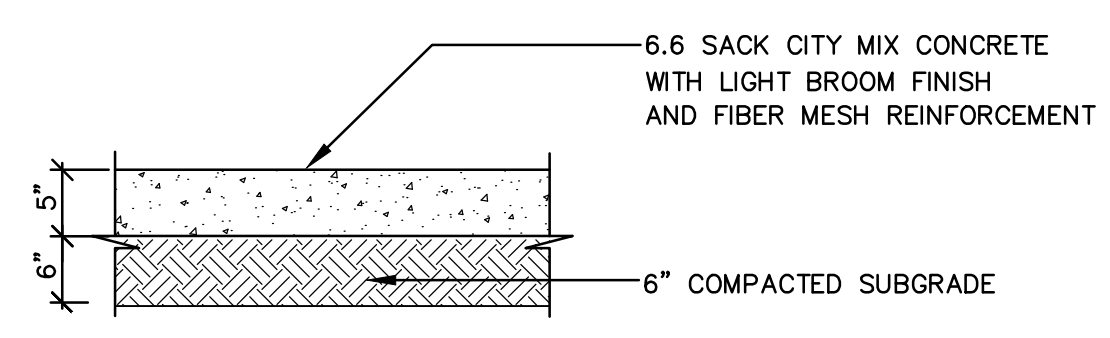

**1 5" SIDEWALK CONCRETE**  
NOT TO SCALE

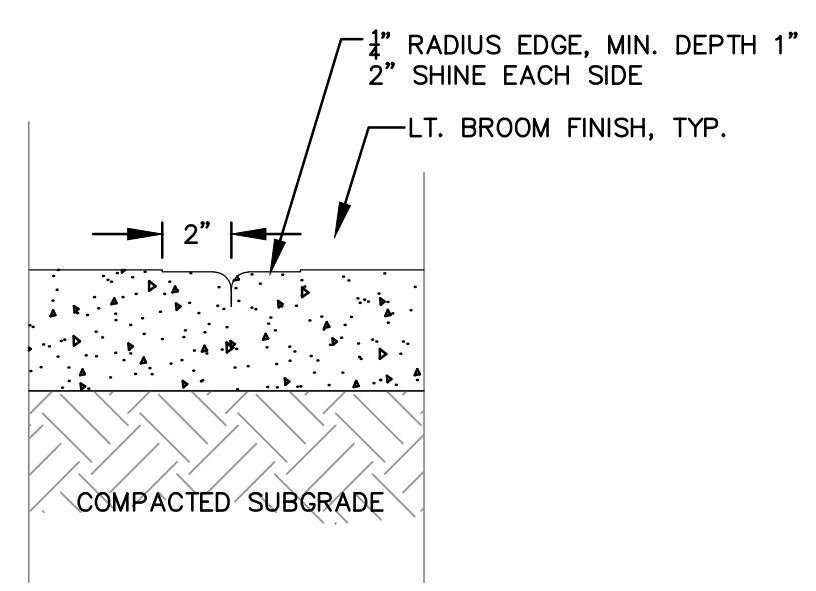

**TOOLED CONTROL JOINT**

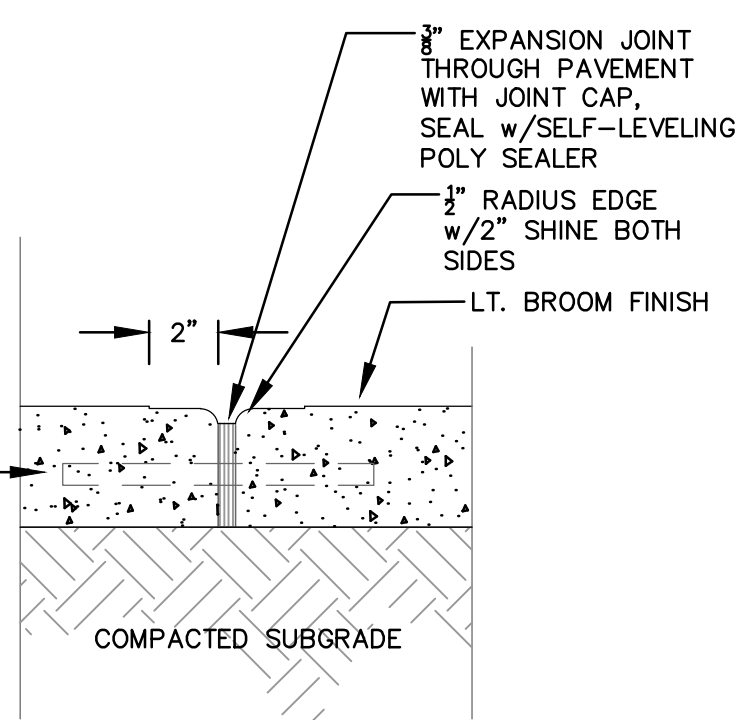

**EXPANSION JOINT**

#5 DOWEL x9",  
CENTERED, 12" O.C.  
OR AS DIRECTED

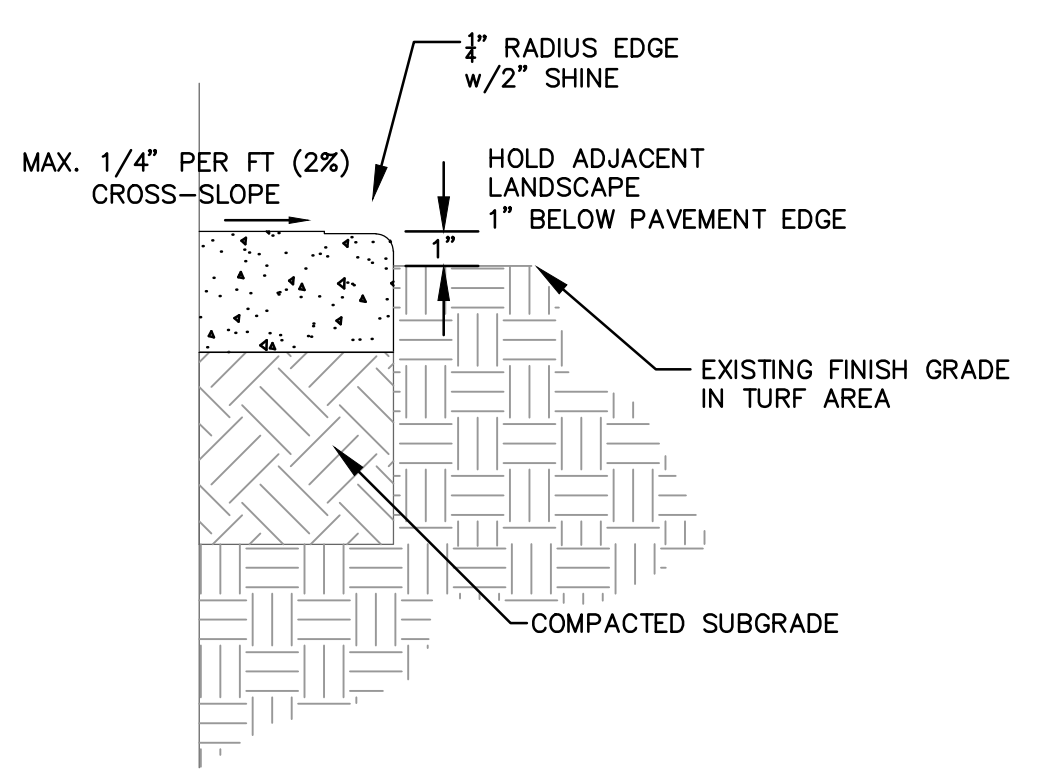

**PAVEMENT EDGE  
at TURF**

**2 CONCRETE JOINT AND EDGE DETAILS**  
NOT TO SCALE

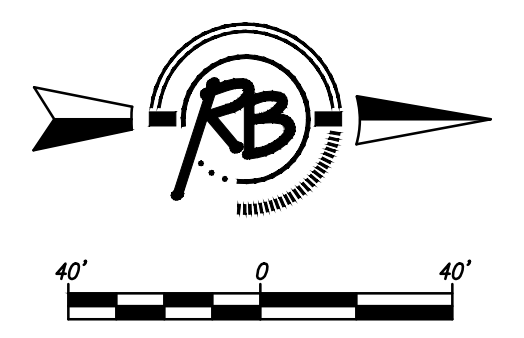
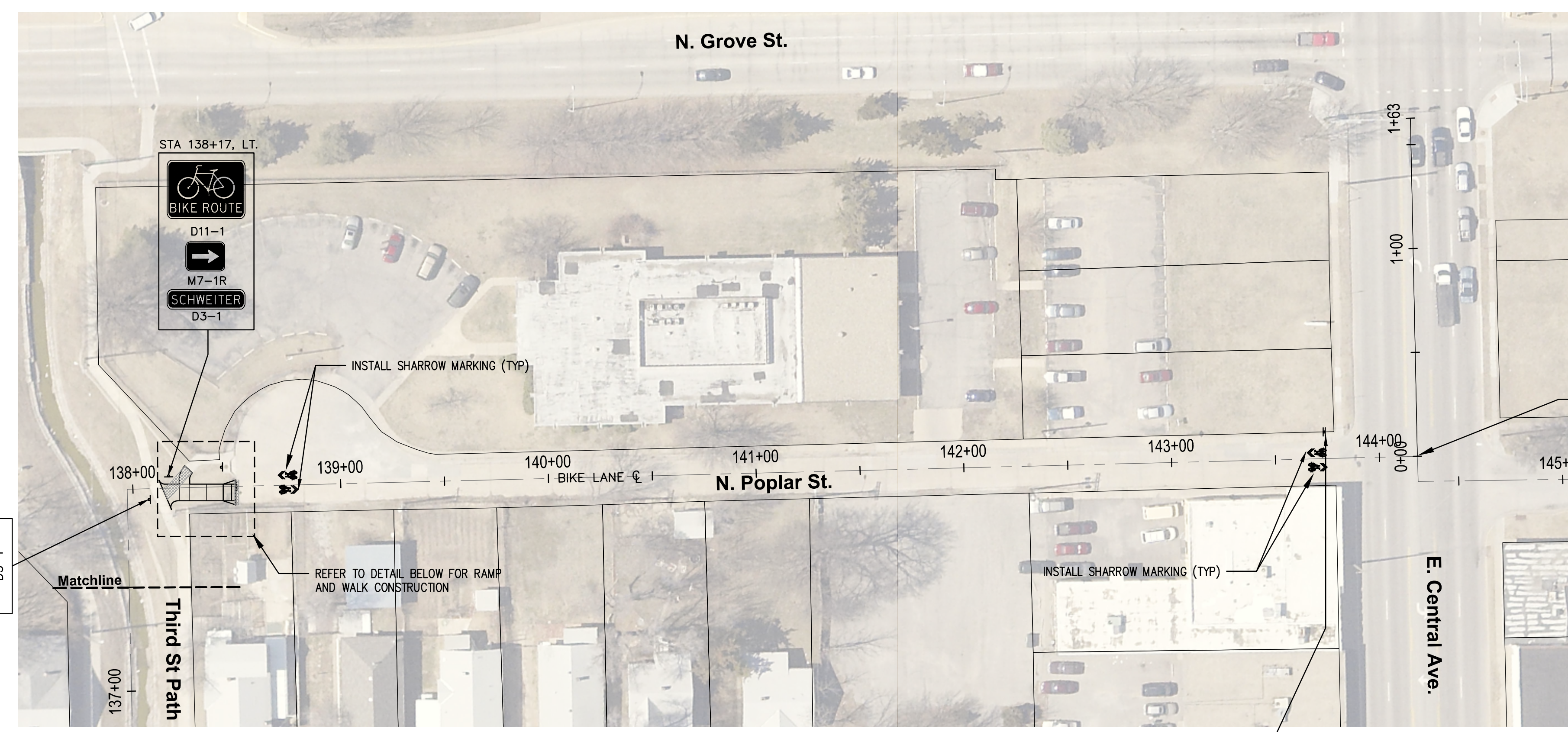

END PHASE 1 BIKE LANE PROJECT  
#87 TE-0620-01  
STA: 144+18.26

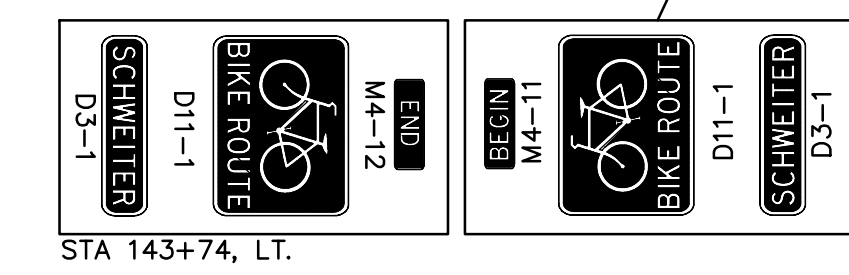
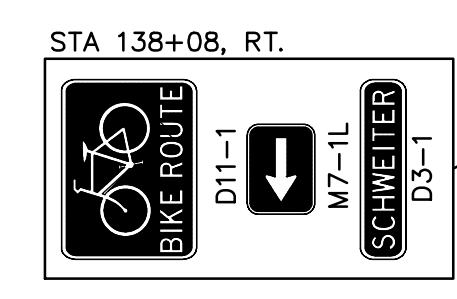

**POPLAR STREET CURB CUT AND SIDEWALK EXTENSION**

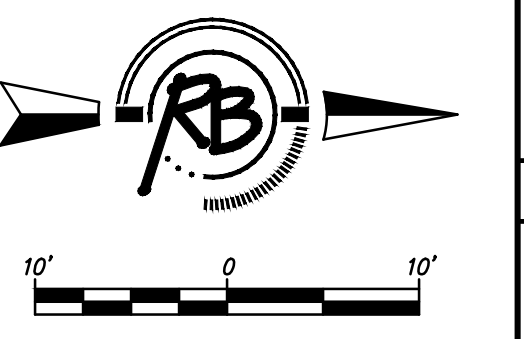
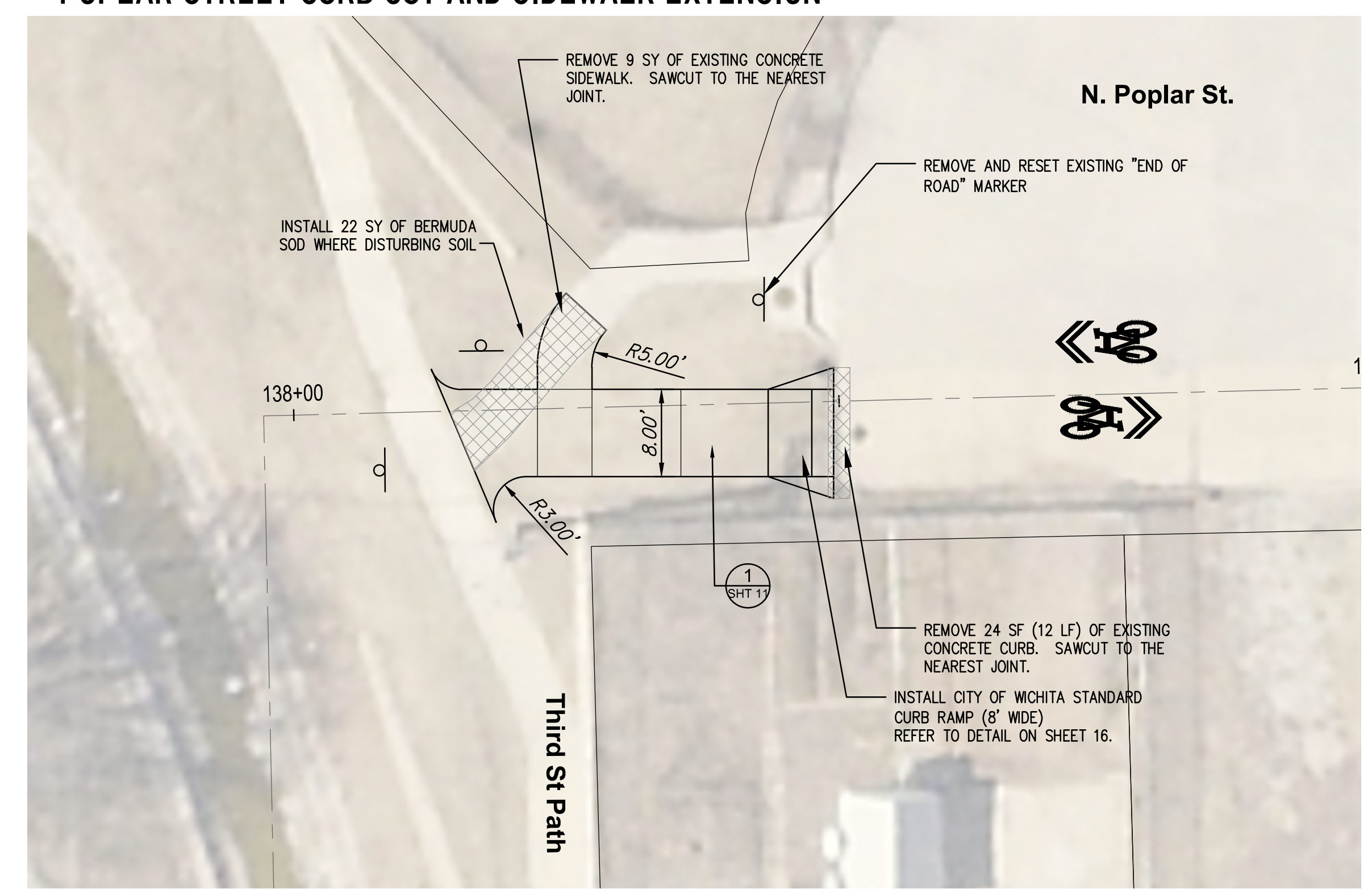

**RUGGLES & BOHM**  
INCORPORATED  
ENGINEERS, ARCHITECTS, PLANNERS  
1000 W. 17TH ST., SUITE 100  
WICHITA, KANSAS 67202  
PH: 316.261.1111  
WWW.RUGGLESANDBOHM.COM

DESIGN: BDT  
UTILITY: xjfy  
DRAWN: BDT  
DATE: xjfy  
REVISION: BDT  
REVIEW: xjfy

PROJECT NUMBER: xjfy  
DRAWING FILE: Bosa [02 Plan]

**PLAN- STA 137+50 TO STA 144+18.26  
SCHWEITER BIKEWAY - PH 1  
WICHITA, KANSAS**

RB JOB #180H  
SHEET 11 OF 18  
© Copyright 2013, Ruggles & Bohm, P.A.