

STANDARD SPECIFICATIONS FOR CHAIN LINK FENCE AND GATES

GENERAL:

THIS SPECIFICATION COVERS CHAIN LINK FENCE INSTALLATION AND MATERIALS INCLUDING CHAIN LINK FABRIC, FRAMEWORK, GATES AND FITTINGS.

FENCE SHALL BE A MINIMUM OF 7'-0" HIGH ABOVE FINISHED GRADE, USING 6'-0" HIGH CHAIN LINK FABRIC AND SURMOUNTED BY THREE (3) STRANDS OF BARBED WIRE.

MATERIALS:

- A. FABRIC: CHAIN LINK FABRIC SHALL BE 9 GAUGE HOT DIP GALVANIZED WITH A MINIMUM OF 1.2 OUNCES OF ZINC PER SQUARE FOOT OF SURFACE AREA WHEN DETERMINED IN ACCORDANCE WITH THE REQUIREMENTS OF ASTM A-90. FABRIC SHALL BE WOVEN IN A 2" DIAMOND MESH AND SHALL BE 72" HIGH. THE TOP SELVAGE SHALL BE TWISTED AND BARBED AND THE BOTTOM SELVAGE MAY BE KNUCKLED OR TWISTED AND BARBED.
- B. FRAMEWORK: ALL LINE POSTS, TERMINALS, BRACES, TOP RAILS, GATE POSTS, AND GATE FRAMES SHALL BE HOT DIP GALVANIZED. GALVANIZING, EXCEPT HIGH STRENGTH PIPE, SHALL BE 1.8 OUNCES OF ZINC PER SQUARE FOOT OF SURFACE AREA WHEN DETERMINED IN ACCORDANCE WITH THE REQUIREMENTS OF ASTM A-53 OR ASTM A-123. HIGH-STRENGTH PIPE SHALL BE COATED WITH A TYPE B COATING IN ACCORDANCE WITH ASTM F 1234.

1. LINE POSTS SHALL BE 1.875" X 1.700" C-SECTION (STD. - C) WEIGHING 2.28 LBS./FT., 2.375" HIGH STRENGTH PIPE WEIGHING 3.12 LBS./FT., 2.375" SCHEDULE 40 PIPE WEIGHING 3.65 LBS./FT., OR POSTS PROVIDING EQUIVALENT OR GREATER STRENGTH CHARACTERISTICS TO THOSE POSTS NOTED.
2. TERMINAL POSTS (END, CORNER, AND PULL) SHALL BE 2.875" HIGH STRENGTH PIPE WEIGHING 4.64 LBS./FT., 2.875" SCHEDULE 40 PIPE WEIGHING 5.79 LBS./FT., OR POSTS PROVIDING EQUIVALENT OR GREATER STRENGTH CHARACTERISTICS TO THOSE POSTS NOTED.
3. GATE POSTS SHALL BE OF THE SIZE AND TYPE RECOMMENDED BY THE GATE MANUFACTURER.
4. TOP RAIL AND BRACE RAILS SHALL BE 1.625" X 1.250" C-RAIL WEIGHING 1.35 LBS./FT., 1.660" HIGH STRENGTH STEEL WEIGHING 1.82 LBS./FT., 1.660" SCHEDULE 40 PIPE WEIGHING 2.27 LBS./FT., OR SECTION PROVIDING EQUIVALENT OR GREATER STRENGTH CHARACTERISTICS TO THOSE RAIL SECTIONS NOTED. TOP RAIL SECTIONS SHALL BE A MINIMUM OF 20'-0", EXCEPT AS NECESSARY TO MAKE CONNECTIONS TO TERMINAL POSTS, AND BE FITTED OR FURNISHED WITH COUPLINGS TO PROVIDE A SATISFACTORY CONNECTION OF ADJACENT SECTIONS.
5. BOTTOM TENSION WIRE SHALL BE NO. 7 GAUGE GALVANIZED STEEL WIRE WITH 1.2 OUNCES OF ZINC PER SQUARE FOOT OF SURFACE AREA.
6. FITTINGS SHALL BE PRESSED STEEL, MALLEABLE IRON, OR CAST IRON OF GOOD COMMERCIAL QUALITY IN CONFORMANCE WITH ASTM F-626. STEEL FITTINGS SHALL BE GALVANIZED WITH 1.2 OUNCES OF ZINC PER SQUARE FOOT IN ACCORDANCE WITH ASTM A-153.
7. GATE FRAMES SHALL BE A MINIMUM OF 1.900" HIGH STRENGTH PIPE, 1.900" SCHEDULE 40 PIPE, OR SECTION PROVIDING EQUIVALENT OR GREATER STRENGTH CHARACTERISTICS. FRAMES FOR LARGE SWING GATES SHALL BE CONSTRUCTED WITH MATERIALS OF THE SIZE AND TYPE RECOMMENDED BY THE GATE MANUFACTURER.
8. GATE AND OTHER MISCELLANEOUS HARDWARE SHALL BE STRUCTURALLY CAPABLE OF SUPPORTING GATES, FABRIC, RAILS, WIRE OR OTHER ITEMS FOR WHICH SAID HARDWARE IS PROVIDED.
9. BARBED WIRE SHALL BE DOUBLE STRAND TWISTED 12 1/2 GAUGE ZINC COATED WIRE WITH 4-POINT BARBS AND SHALL COMPLY WITH THE REQUIREMENTS OF ASTM A-121, CLASS 3.
10. FENCING CONTRACTOR SHALL PROVIDE AND INSTALL PRIVACY SLATS IN CHAIN LINK FENCE FABRIC. SLAT COLOR SELECTION BY OWNER.

C. GATES:

1. FRAMES MAY BE ASSEMBLED BY WELDING OR WITH USE OF SUITABLE STEEL HARDWARE FITTINGS. ALL WELDED AREAS SHALL BE COVERED WITH A RUST PREVENTATIVE COATING. ALL HARDWARE USED, INCLUDING SUPPORTS, ROLLERS AND LATCHES, SHALL BE OF ADEQUATE DESIGN AND STRENGTH TO PROVIDE SATISFACTORY OPERATION OF THE GATE(S). INTERIOR BRACING SHALL BE PROVIDED AS RECOMMENDED BY THE MANUFACTURER.
2. GATE FABRIC SHALL BE OF THE SAME TYPE, SIZE OF MESH, GAGE SIZE OF WIRE AND SELVAGE AS THAT SPECIFIED FOR FENCE.
3. THE END MEMBERS OF THE GATE FRAMES SHALL EXTEND ONE (1) FOOT ABOVE THE TOP HORIZONTAL SECTION OF THE GATE FRAME. THREE STRANDS OF BARBED WIRE SHALL BE UNIFORMLY SPACED AND SHALL BE ATTACHED TO THE ONE (1) FOOT EXTENSIONS BY BANDS, CLIPS OR EYEBOLTS.
4. LATCHES, HINGES, STOPS AND KEEPERS SHALL BE GALVANIZED STEEL. THE GALVANIZED COATING SHALL BE 1.2 OUNCES OF ZINC PER SQUARE FOOT UNLESS OTHERWISE SPECIFIED.
5. SINGLE GATE LATCHES SHALL BE FORK TYPE, GRAVITY DROP BAR TYPE WITH POSITIVE LOCKING FEATURES OR PLUNGER BAR TYPE OF FULL GATE HEIGHT.
6. DOUBLE GATE LATCHES SHALL BE FORK TYPE LATCH WITH CENTER DROP ROD, OR PLUNGER BAR TYPE OF FULL GATE HEIGHT ARRANGED TO ENGAGE THE GATE STOP, OR A POSITIVE LOCKING GRAVITY DEVICE. LOCKING DEVICES SHALL BE CONSTRUCTED SO THAT THE CENTER DROP ROD OR PLUNGER BAR CANNOT BE RAISED WHEN LOCKED.
7. CENTER GATE STOP SHALL BE PROVIDED FOR ALL DOUBLE GATES AND SHALL BE SUITABLE FOR SETTING IN CONCRETE OR WITH ANCHORS FOR THE CENTER DROP ROD OR PLUNGER.
8. KEEPERS SHALL BE PROVIDED FOR EACH GATE LEAF OVER FIVE (5) FEET WIDE. GATE KEEPERS SHALL CONSIST OF A MECHANICAL DEVICE FOR SECURING THE FREE END OF THE GATE WHEN IN FULL OPEN POSITION.
9. GATE HINGES SHALL BE OF ADEQUATE STRENGTH FOR THE GATE, AND SHALL HAVE LARGE BEARING SURFACES FOR CLAMPING OR BOLTING IN POSITION. HINGE ACTION SHALL BE SUCH THAT GATES MAY BE EASILY OPENED AND CLOSED BY ONE PERSON. HINGES SHALL PROVIDE FOR FULL 180 SWING OF GATE LEAF.
10. SINGLE OR DOUBLE CANTILEVER OR ROLLER GATES SHALL BE FURNISHED WHEN SPECIFIED ON THE PLANS. ROLLER OR CANTILEVER GATES SHALL BE OF A TYPE SUITABLE FOR FITTING OF ELECTROMECHANICAL OPERATORS WHETHER SPECIFIED OR NOT. DIRECTION OF OPERATION AND MINIMUM CLEAR OPENING SHALL BE THAT SHOWN ON THE PLANS OR SPECIFIED BY THE OWNER.
11. PADLOCKS WILL BE FURNISHED BY THE OWNER.
12. ALL GATES FURNISHED SHALL BE INDUSTRIAL STANDARD. SHOP DRAWINGS AND/OR CATALOG CUTS OF PROPOSED GATE DESIGN SHALL BE SUBMITTED FOR THE OWNER'S APPROVAL PRIOR TO ASSEMBLY AND DELIVERY TO THE SITE.

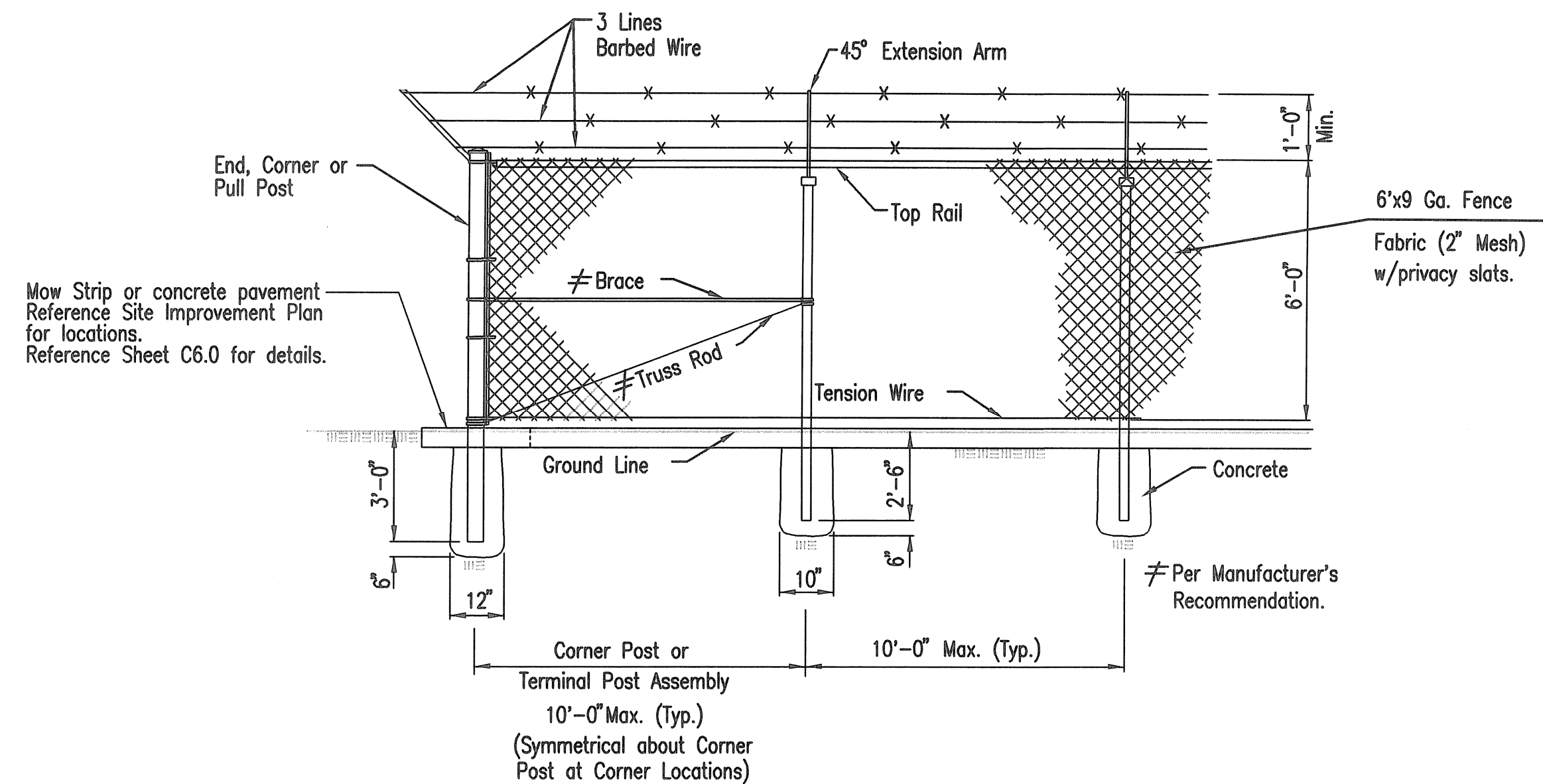

CHAIN LINK FENCE WITH BARBED WIRE

INSTALLATION:

- A. LINE POSTS SHALL BE OF SUFFICIENT LENGTH TO ALLOW FOR AN APPROXIMATE 30° SETTING INTO CONCRETE FOOTINGS. CONCRETE FOOTINGS FOR LINE POSTS SHALL BE A MINIMUM OF 10" DIAMETER WITH A MINIMUM OF 6" OF CONCRETE BELOW THE BOTTOM OF THE POSTS. PULL, END AND CORNER POSTS SHALL BE OF SUFFICIENT LENGTH TO ALLOW FOR AN APPROXIMATE 36° SETTING INTO CONCRETE FOOTINGS. CONCRETE FOOTINGS FOR THESE POSTS SHALL BE A MINIMUM OF 12" IN DIAMETER WITH A MINIMUM OF 6" OF CONCRETE BELOW THE BOTTOM OF THE POSTS. GATE POSTS AND THEIR FOOTINGS SHALL BE IN ACCORDANCE WITH THE RECOMMENDATIONS OF THE GATE MANUFACTURER. POSTS, OTHER THAN GATE POSTS, SHALL BE SET AT 10'-0" MAXIMUM CENTERS. PULL POSTS SHALL BE INSTALLED AT SHARP BREAKS IN VERTICAL GRADE, OR AT MAXIMUM 330' CENTERS ON STRAIGHT RUNS, OR AS OTHERWISE DIRECTED BY THE ENGINEER.
- B. CHAIN LINK FABRIC SHALL BE ATTACHED TO TERMINAL POSTS WITH MINIMUM 1/4" X 3/4" TENSION BARS AND 12 GAUGE BY 1" WIDE CLAMPS USING MINIMUM 3/8" DIAMETER CARRIAGE BOLTS. FABRIC SHALL BE FASTENED TO TOP RAIL, LINE POSTS AND TENSION WIRE WITH 9-GAUGE MINIMUM FABRIC TIE WIRES SPACED AT 24" MAXIMUM CENTERS OR WEAVED DIRECTLY INTO INTEGRAL LOCK LOOPS AS MAY BE FORMED IN THE POST(S) PROVIDED.
- C. EXTENSION ARMS TO ACCOMMODATE THE SURMOUNTED BARBED WIRE SHALL SLOPE AT A 45 DEGREE ANGLE TO THE OUTSIDE OF THE AREA BEING PROTECTED BY THE FENCE AND SHALL PROVIDE FOR AN APPROXIMATE 5" SPACING OF THE BARBED WIRE. SURMOUNTED BARBED WIRE SHALL BE SECURELY ATTACHED TO THE GATES AS RECOMMENDED BY THE GATE MANUFACTURER AND MAY BE MOUNTED IN A VERTICAL PLANE PARALLEL TO THAT OF THE GATE.
- D. ALL WORK SHALL BE ACCOMPLISHED BY MECHANICS SKILLED IN THE TRADE. ALL WORK, NOT OTHERWISE SHOWN ON THE PLANS OR DIRECTLY DESCRIBED HEREIN, SHALL BE IN ACCORDANCE WITH THE RECOMMENDATIONS OF THE MANUFACTURER AND THE CHAIN LINK FENCE MANUFACTURER'S INSTITUTE, UNLESS OTHERWISE APPROVED BY THE OWNER.
- E. ALL DIMENSIONS AND GAUGES OF MATERIAL ARE SUBJECT TO ACCEPTED INDUSTRY TOLERANCE STANDARDS. THE JOB SITE SHALL BE CLEARED OF ALL EXCESS SPILLAGE OF CONCRETE, CUT WIRES, ETC., AND MATERIAL REMOVED FROM POST HOLES SHALL BE REMOVED FROM THE SITE OR UNIFORMLY SCATTERED AS MAY BE APPROVED BY THE OWNER.
- F. UPON REQUEST OF THE OWNER OR OWNER'S AUTHORIZED REPRESENTATIVE, SAMPLES OF EACH COMPONENT AND/OR MILL CERTIFICATES CONFIRMING COMPLIANCE WITH THESE SPECIFICATIONS SHALL BE FURNISHED. ANY AND ALL MATERIAL AND WORK FOUND NOT TO BE IN COMPLIANCE WITH THE HEREIN DESCRIBED SPECIFICATIONS SHALL BE REMOVED AND REPLACED TO THE OWNER'S SATISFACTION AT THE CONTRACTOR'S EXPENSE.

Saved 02-23-2015 8:19:44 AM by CAL
 Plot Scale: 1/4" = 1'-0"
 P:\Projects\2015\11-17-15\11-17-15.dwg
 P:\Projects\2015\11-17-15\11-17-15.dwg

	Revision		
No.	By	Date	
CITY OF WICHITA, KANSAS			
FENCE DETAILS			
WWP #2 EMERGENCY POWER PROJECT C.O.W. PROJECT NO. 468-84956			
PEC PROFESSIONAL ENGINEERING CONSULTANTS, P.A. 303 SOUTH TOPEKA WICHITA, KS 67202 316-262-2691 www.pec1.com			
Designed by	MEB	Job No.	34-14229-001-0042
Drawn by	CAL	Date	February 2015
			Sht. C5.0 of 36