

**TYLER ROAD TYPICAL SECTION**  
Sta. 20+25.00 to Sta. 22+00.00

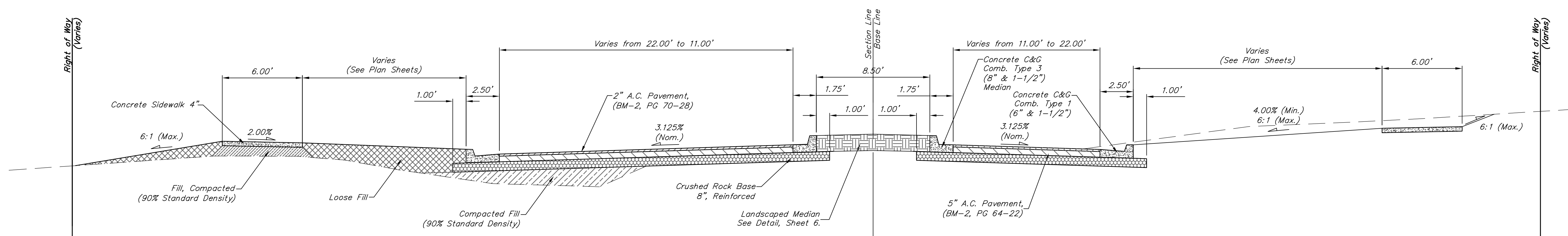

**TYLER ROAD TYPICAL SECTION**  
Sta. 29+00.00 to Sta. 35+75.00

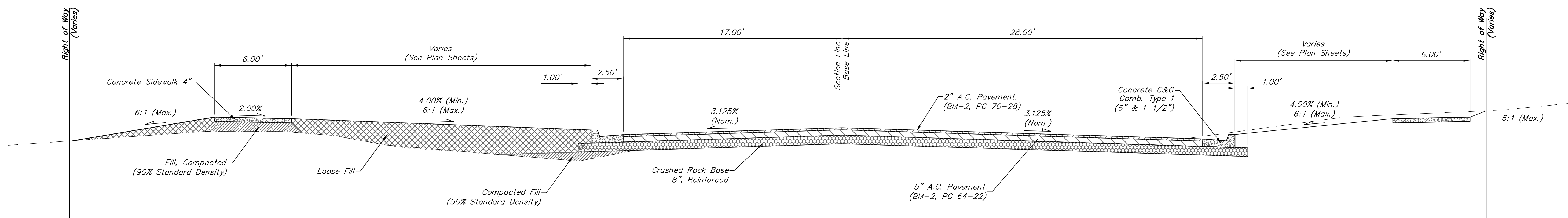

**TYLER ROAD TYPICAL SECTION**  
Sta. 35+75.00 to Sta. 36+15.50  
Sta. 37+19.15 to Sta. 39+00.00  
Sta. 41+50.00 to Sta. 43+53.23