

CONSTRUCTION PLAN FOR PRIVATE WATER DISTRIBUTION SYSTEM IMPROVEMENTS

AAA MINI STORAGE

TO

THE CITY OF WICHITA, KANSAS

GARY JANZEN, P.E. - INTERIM CITY ENGINEER

1689 PPW OCA NO. 607853

NOT AN AS-BUILT

General Notes

- Contractor will be required to provide notice to utility companies a minimum of seventy-two (72) hours prior to any excavation, as follows:

Kansas One-Call 687-2470

The Contractor must notify the following in case of an emergency:

Cox Communications (Cable) 262-0661
 Westar Energy (Electric) 261-6512
 Kansas Gas Service (Gas) 832-3101
 AT&T (Telephone) 1-800-870-8390
 City of Wichita Water & Sewer 262-6000
 Black Hills Energy 1-800-303-0357

- All water mains and appurtenances shall be installed in accordance with City of Wichita, Kansas Standard Specifications for Water Main Installations No. 14533.

- The water main shall be constructed on the alignment shown by the plans. Trees and shrubs in public right-of-way which are in direct conflict with proposed new construction shall be removed by the Contractor with the Engineer's approval. Trees and shrubs which are not in direct conflict with proposed new construction shall be saved and protected from damage. The cost for any necessary tree trimming, clearing and/or grubbing shall be included in the price bid for the installed water main pipe.

- Opening and closing of water valves shall be done slowly to prevent damage to the water distribution system from water hammer. All valves closed by the contractor must be reopened as new construction permits. Project inspector must ascertain that any valve closed by the contractor is reopened. Contractor will be permitted to operate water valves only when the project inspector assigned to the project is present.

- Contractor shall not start work on the project until the project inspector is assigned to the project and is present on the site. Any work done without inspection will be required to be uncovered for inspection.

- Underground utility service lines and overhead utility pole lines are to be adjusted as necessary by others prior to construction, unless the plans specifically call for their adjustment by the Contractor. Existing utilities and their locations, as shown on the plans, represent the best information obtainable for design. Location information has been obtained from the various utility companies and is either from company record drawings or company-provided field locations. The Contractor will be required to work around existing utilities within the right-of-way which do not conflict with proposed construction.

- The Contractor shall give all property owners and/or tenants of developed property directly abutting the construction of this project a minimum of ten (10) days notice prior to start of construction.

- The Contractor shall be responsible for preserving property irons. The Contractor will be required to re-establish any property irons which are damaged or destroyed by his construction operations. Such irons shall be re-established by a licensed land surveyor in accordance with state law.

- All areas disturbed by construction operations shall be seeded with rye grass at a rate of 300 lbs/acre immediately following construction in that area. Ground shall be prepared per City of Wichita specifications prior to seeding.

- The Contractor shall be responsible for all testing, inspection, staking, and other work as necessary to complete the project.

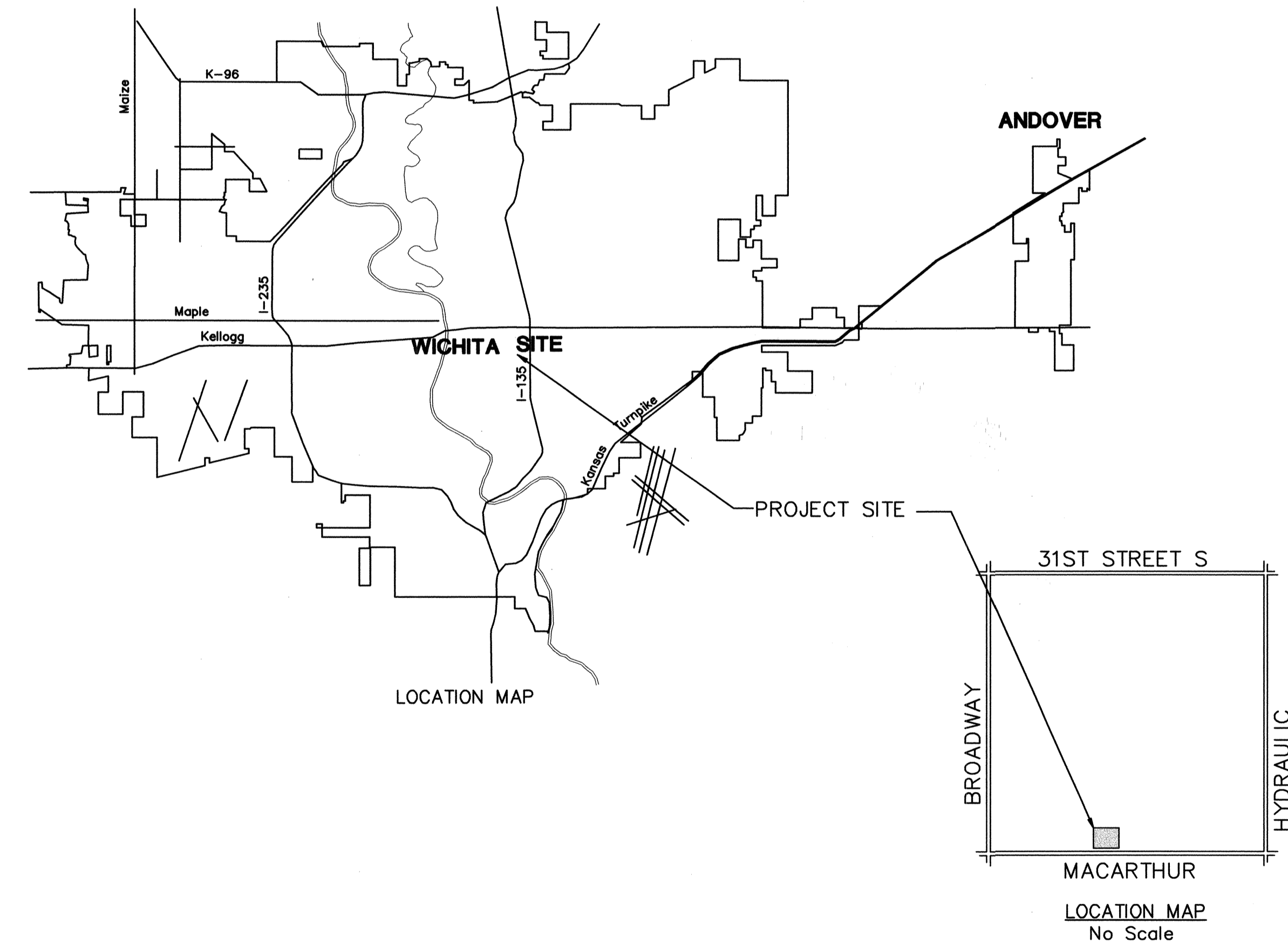
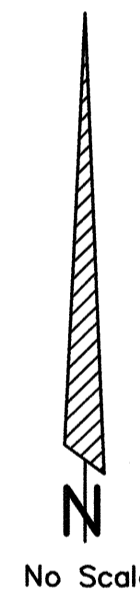

INDEX OF SHEETS

SHEET NO.	TITLE SHEET
1	TITLE SHEET
2	STANDARD DETAILS
3	PLAN PROFILE
4-9	EROSION CONTROL
10	PLAT

APPROVED AS NOTED
 BY CITY ENGINEER OF WICHITA,
 BY WICHITA WATER & SEWER DEPARTMENT,
 & BY WICHITA FIRE DEPARTMENT

Public Works: [Signature] 9-26-12
 Water & Sewer: [Signature] 9-26-12
 Fire: [Signature] 9-26-2012

NOTE TO CONTRACTORS

Public Property:
 Inspection and testing for the waterline is to be provided by a Licensed Consulting Engineering Firm under contract with the Owner/Developer. Said inspection to be in accordance with the City of Wichita standard construction engineering practices and certified by a Professional Engineer Licensed in the state of Kansas. No work shall be performed in dedicated easements or public right-of-way by the Contractor without such inspection nor shall any work be commenced without written authorization by the City Engineer. All Construction and Materials shall comply with the City or Wichita Specifications and Standards (on file and available in the City Engineer's Office).

Private Property:
 Installation and testing for the fire protection line is to be performed by a City of Wichita licensed fire protection contractor in accordance with the fire codes as adopted by the City of Wichita. All material and construction practices for the fire protection line shall comply with the fire codes as adopted by the City of Wichita (available from the City of Wichita Fire Department). The Contractor shall not commence work without notification and approval of the Wichita Fire Department. Inspection of the fire protection line is to be provided by a Licensed Engineering Firm under contract with the Owner/Developer and the Fire Department. The contractor shall not start work until the project inspector is assigned to the project and present on the site. Any work done without inspection will be required to be uncovered for inspection.

AUGUST 2012
 PLANS PREPARED BY

POE & ASSOCIATES, INC.
 5940 E. Central, Suite 200 ■ Wichita, KS 67208-4242
 Phone 316/685-4114 ■ FAX 316/685-4444

Approved	Revision
By	
Date	
No.	
AAA MINI STORAGE 530 EAST MACARTHUR ROAD WATER DISTRIBUTION SYSTEM IMPROVEMENTS CITY OF WICHITA, KANSAS GARY JANZEN, P.E. - INTERIM CITY ENGINEER C.O.N. Proj.# 1689 PPW OCA# 607853	
POE & ASSOCIATES, INC. CONSULTING ENGINEERS 5940 E. Central, Suite 200 ■ Wichita, KS 67208-4242 Phone 316/685-4114 ■ FAX 316/685-4444	
Engineer: S. SERVIS Designer: P. 1109P Drawing: AAA STORAGE\BaseWL.dwg Date: 9/25/2012	
Sheet	
1	of 10

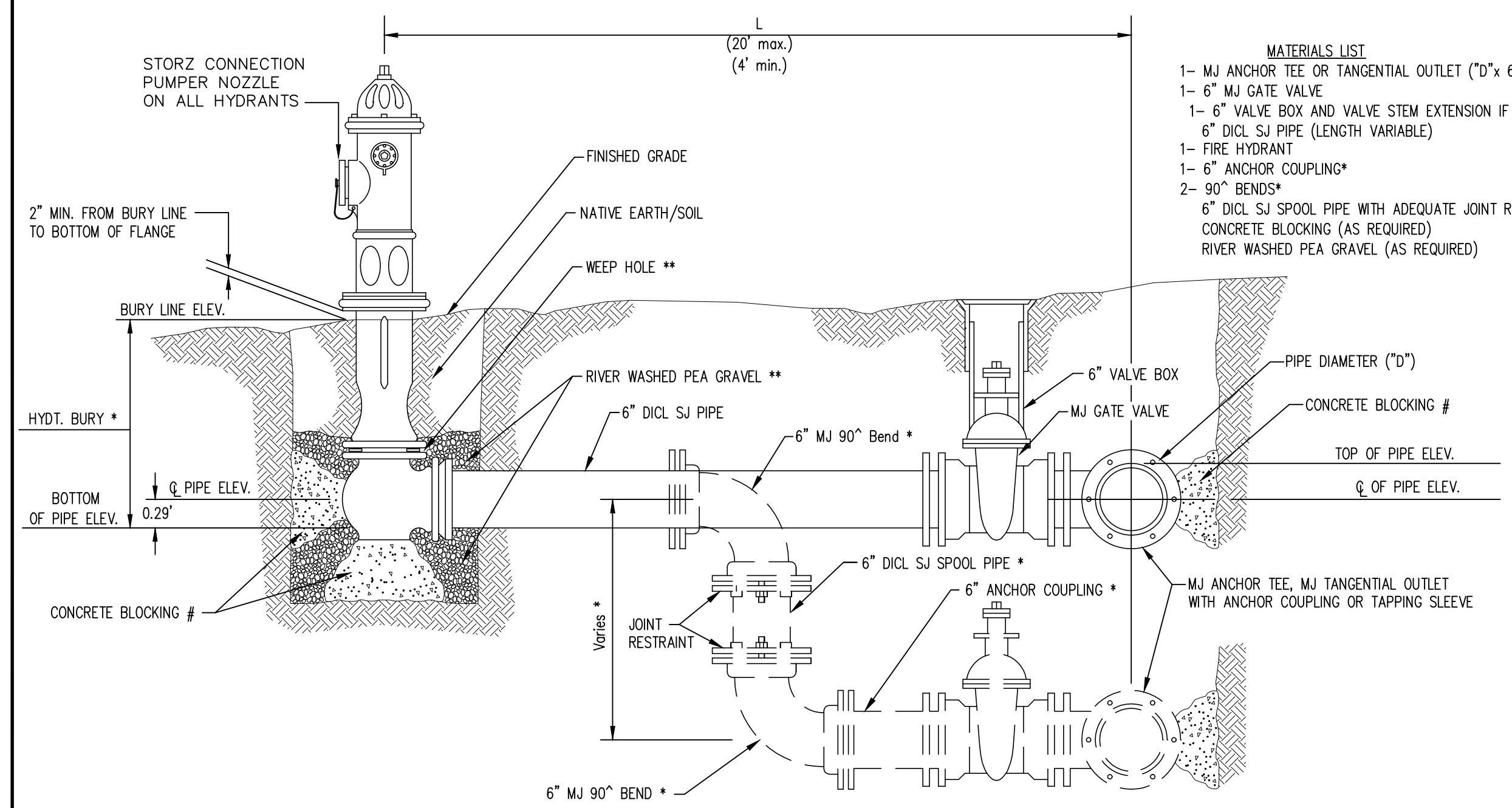

- MATERIALS LIST**
- 1- MJ ANCHOR TEE OR TANGENTIAL OUTLET ("D"x 6")
 - 1- 6" MJ GATE VALVE
 - 1- 6" VALVE BOX AND VALVE STEM EXTENSION IF REQUIRED *
 - 6" DI CL SJ PIPE (LENGTH VARIABLE)
 - 1- FIRE HYDRANT
 - 1- 6" ANCHOR COUPLING*
 - 2- 90° BENDS*
 - 6" DI CL SJ SPOOL PIPE WITH ADEQUATE JOINT RESTRAINT *
 - CONCRETE BLOCKING (AS REQUIRED)
 - RIVER WASHED PEA GRAVEL (AS REQUIRED)

- * IF THE REQUIRED HYDRANT BURY IS IN EXCESS OF 5', BUT LESS THAN 7', CONTRACTOR SHALL USE STANDARD 5' HYDRANT BURY AND HYDRANT BARREL EXTENSIONS AS NECESSARY. IF THE REQUIRED HYDRANT BURY IS GREATER THAN 7', CONTRACTOR SHALL USE 5' HYDRANT BURY, 2-MJ 90° BENDS, 6" ANCHOR COUPLING AND 6" DI CL SPOOL PIPE AS NECESSARY FOR VERTICAL ADJUSTMENT. THE CONTRACTOR SHALL PROVIDE ADEQUATE THRUST BLOCKING AT HYDRANT AND MEGALUGS, ROD AND LUG OR SIMILAR RESTRAINT BETWEEN 90° BENDS TO SECURE ALL FITTINGS DURING TESTING AND OPERATION. THE CONTRACTOR SHALL PROVIDE A VALVE STEM EXTENSION PER DETAIL THIS SHEET.
- ** CAUTION! WEEP HOLES TO BE KEPT CLEAR DURING CONSTRUCTION AND BACKFILL. CONCRETE FOR THRUST BLOCKING SHALL NOT OBSTRUCT WEEP HOLES. PLACE 1 CUBIC FOOT OF RIVER WASHED PEA GRAVEL AROUND EACH WEEP HOLE.
- # CONCRETE THRUST BLOCKING SHALL BE KEPT CLEAR OF BOLTS, NUTS, AND MJ ACCESSORIES.

FIRE HYDRANT ASSEMBLY
PER CITY OF WICHITA SPECIFICATIONS

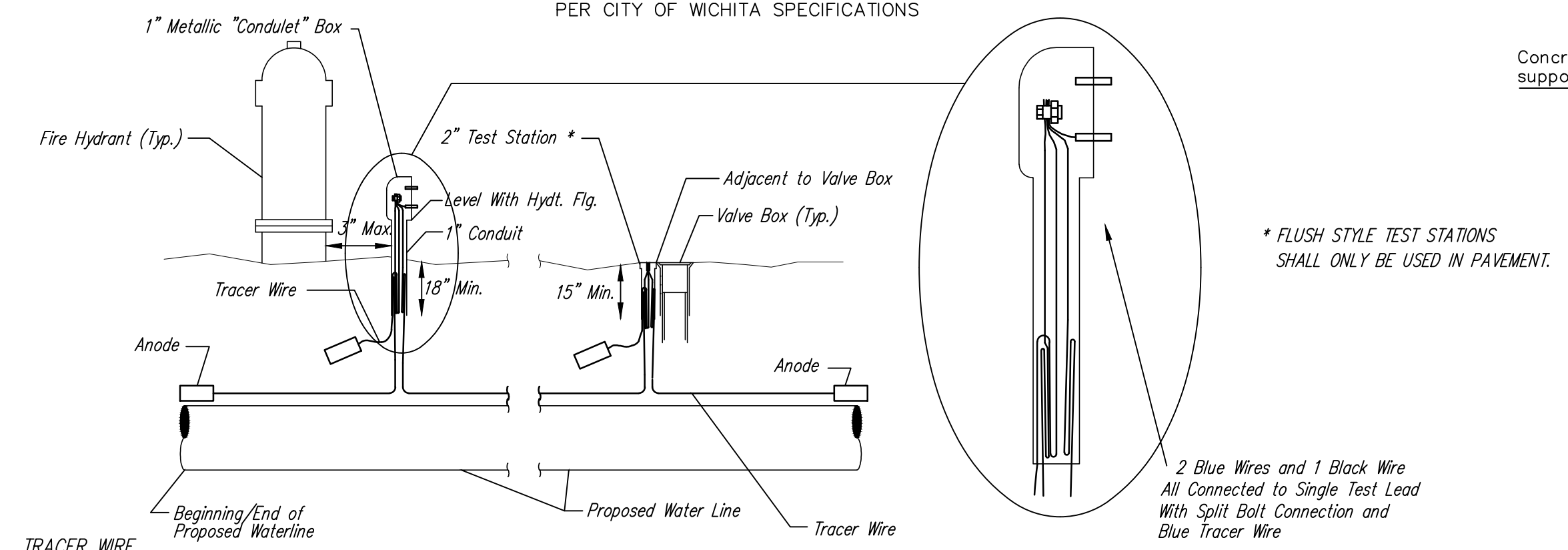

TRACER WIRE
Conductive type pipe locator/tracer wire shall be installed to locate all waterline pipe regardless of pipe material. The wire shall extend the entire length of the proposed pipe. The wire shall be taped to the waterline and pulled with the pipe. Split-bolt connectors shall be used at splice locations. Electrical tape shall cover all splices so no bare wire is exposed. Test stations shall be installed adjacent to all fire hydrants along the waterline and at blowoffs or valves near the ends of the waterlines. Any exceptions to the location of test stations shall be approved by the engineer. At each test station, the tracer wire shall be connected to a 3 lb. Zinc or magnesium anode. Anodes shall also be attached to the tracer wire at both the beginning and the end of the proposed waterline. A typical layout of the tracer wire and test station is provided in the above figure.

WIRES
The tracer wire shall be Blue No. 12 THHN annealed soft copper wire with thermal plastic insulation or Blue No. 12 AWG CCS with 30 mil HDPE insulation. The insulation shall be heat, oil, and gasoline resistant as manufactured by Temple Electric or approved equal. To allow for grade adjustment, a minimum of 12" of excess wire shall be coiled at the bottom of the test station for all wires. The insulation sheathing shall be removed such that 1" bare copper wire at all points of connection. Contractor shall attach wire being installed with proposed water main to any tracer wire installed with adjacent waterline projects.

TEST STATIONS
The test station for fire hydrant applications shall be a 1 inch galvanized "condulet" style test station as manufactured by AGRA Industries with a removable solid cover having two leads extending from the face or approved equal. The test station for valve applications shall be 2 inch flush style test station T2PS3B as manufactured by HANDLEY Industries or approved equal. The "condulet" style test station shall be attached to a 1 inch rigid galvanized conduit with a minimum length of 36" and plastic end bushing. The flush style shall have the word "WATER" stamped or molded into the lid. All test stations shall be manufactured using molded blue tops or sufficiently coated with blue enamel paint. The tracer wire and the anode wire shall be installed to allow 10 inches of wire within the test station. In concrete environments such as sidewalks or in the downtown area the contractor shall use the flush style test station. The location of all test stations shall be approved by the engineer, recorded, and shown in the as-built drawings.

ANODES
The anodes shall be 3 lb. bare zinc or magnesium. The anodes shall be buried at the same elevation as the waterline at each test station. The anodes shall be connected to Black No. 12 THHN annealed soft copper wire which shall be extended to the test station.

TRACER WIRE DETAIL
COST IS SUBSIDIARY TO PIPE INSTALLATION

FIRE HYDRANTS REQUIRED

STATION	BURY LINE ELEVATION	TOP OF PIPE ELEVATION	FIRE HYDRANT BURY REQUIRED*	VALVE STEM EXT. REQUIRED (ft)*
LINE 1-2+89.06	1277.06	1273.37	4.5'	0'

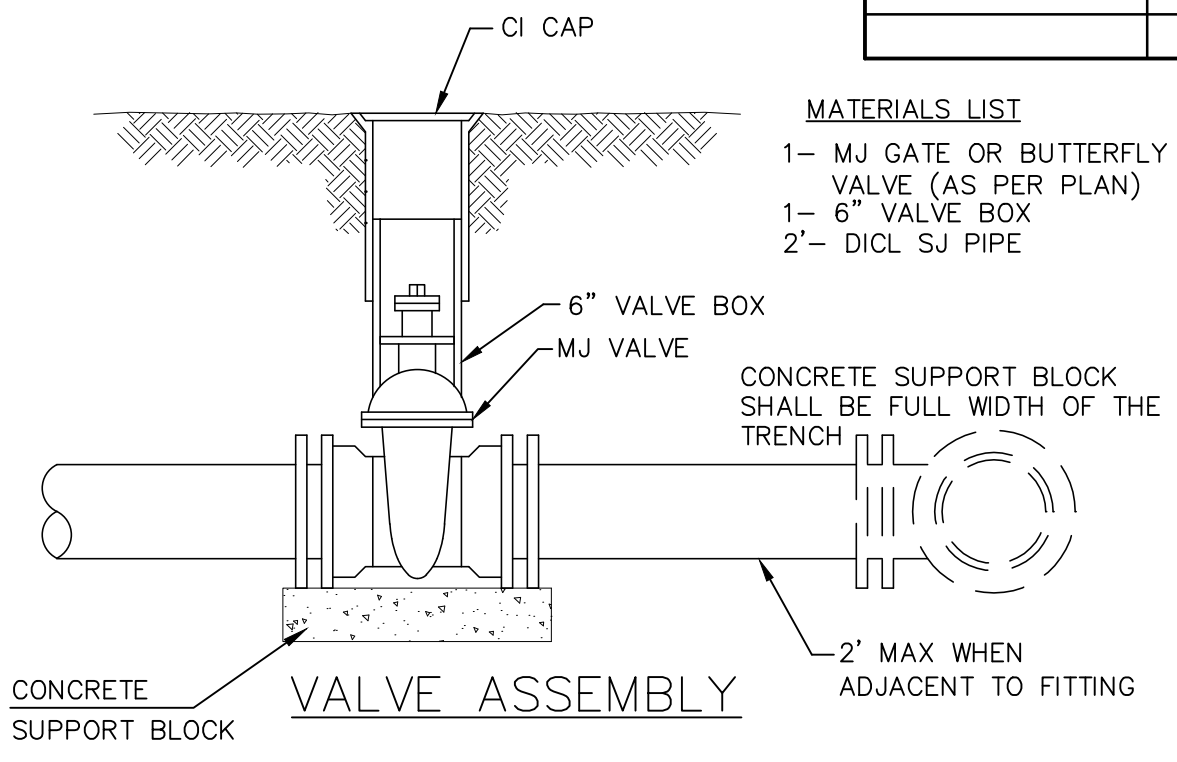

- MATERIALS LIST**
- 1- MJ GATE OR BUTTERFLY VALVE (AS PER PLAN)
 - 1- 6" VALVE BOX
 - 2- DI CL SJ PIPE

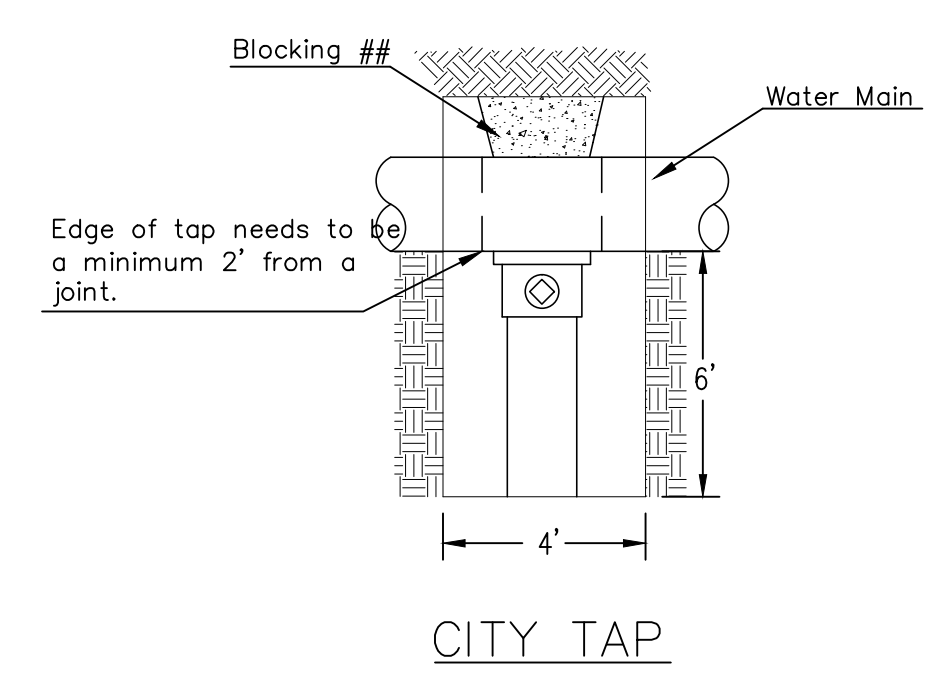

When the City of Wichita makes tap, blocking is to be done by Contractor

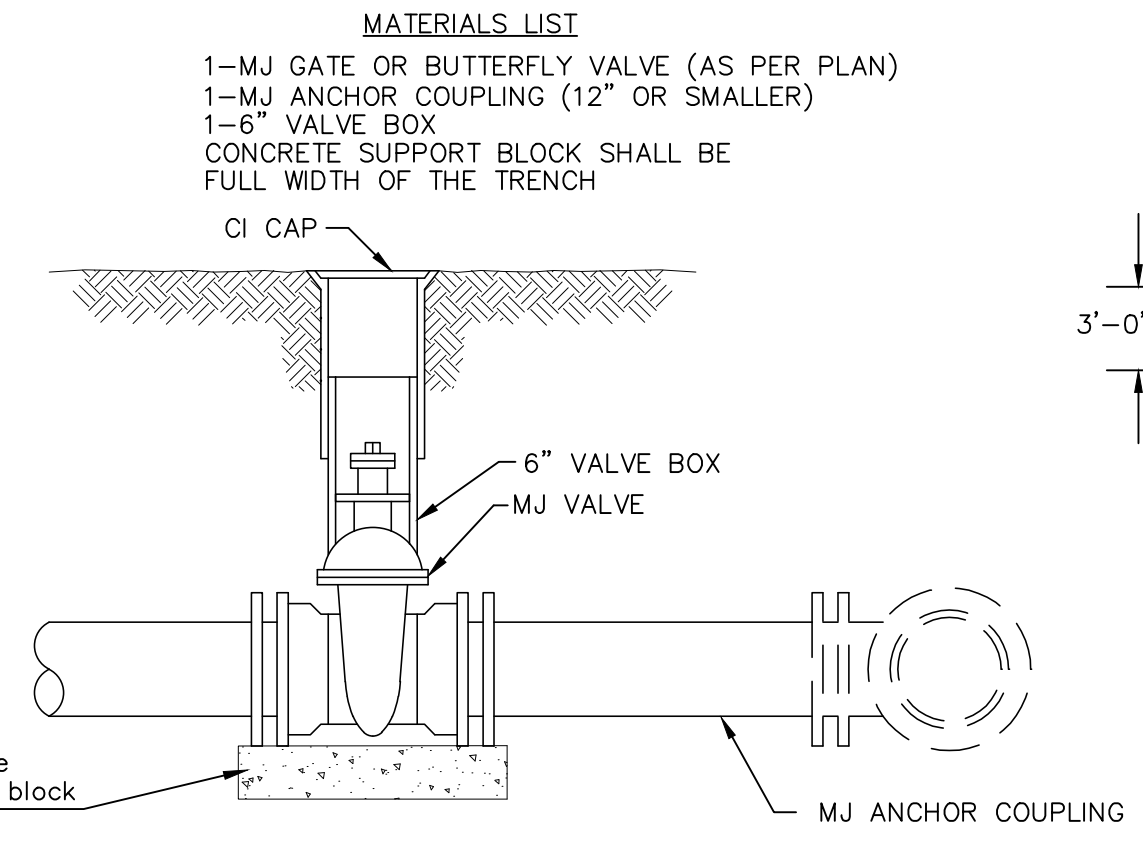

- MATERIALS LIST**
- 1-MJ GATE OR BUTTERFLY VALVE (AS PER PLAN)
 - 1-MJ ANCHOR COUPLING (12" OR SMALLER)
 - 1-6" VALVE BOX
 - CONCRETE SUPPORT BLOCK SHALL BE FULL WIDTH OF THE TRENCH

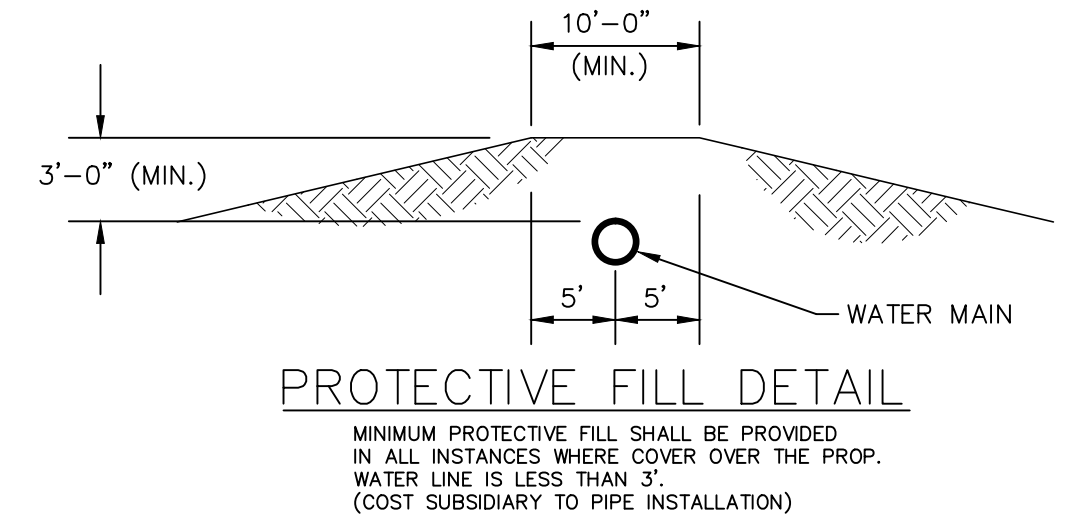

MINIMUM PROTECTIVE FILL SHALL BE PROVIDED IN ALL INSTANCES WHERE COVER OVER THE PROP. WATER LINE IS LESS THAN 3'. (COST SUBSIDIARY TO PIPE INSTALLATION)

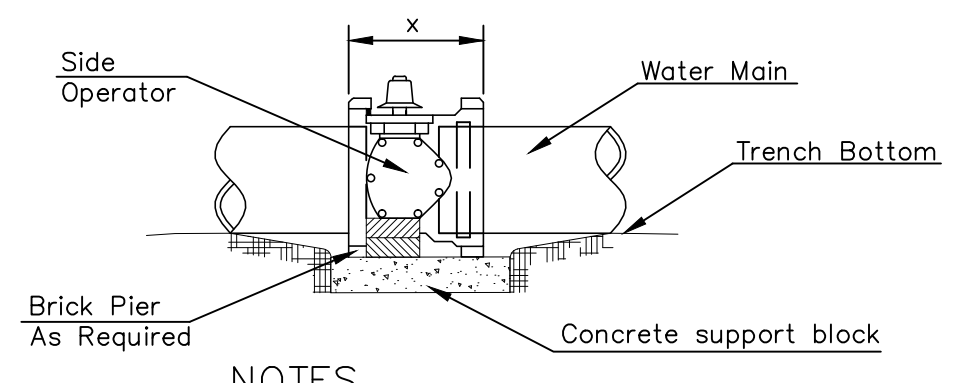

- NOTES**
- This detail covers Butterfly Valve installation, inclusive, regardless of type of pipe or joint used. 24" and larger lines to be detailed on plans.
 - 6" Valve Box and Cover required per City of Wichita Std. Specifications.
 - Conc. Support Block to be full width of trench.

CONCRETE SUPPORT BLOCKING FOR BUTTERFLY VALVE INSTALLATION

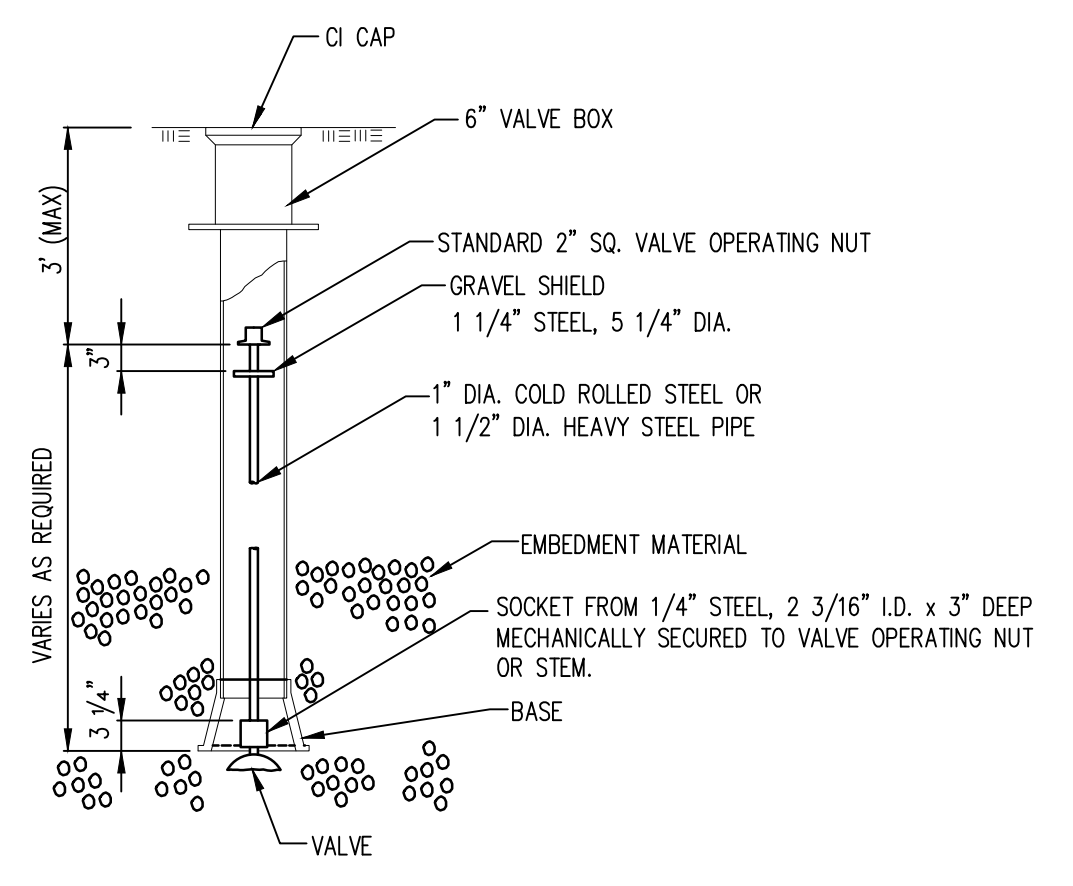

NOTE: ONE VALVE STEM EXTENSION FOR EACH VALVE BURIED GREATER THAN 5'.

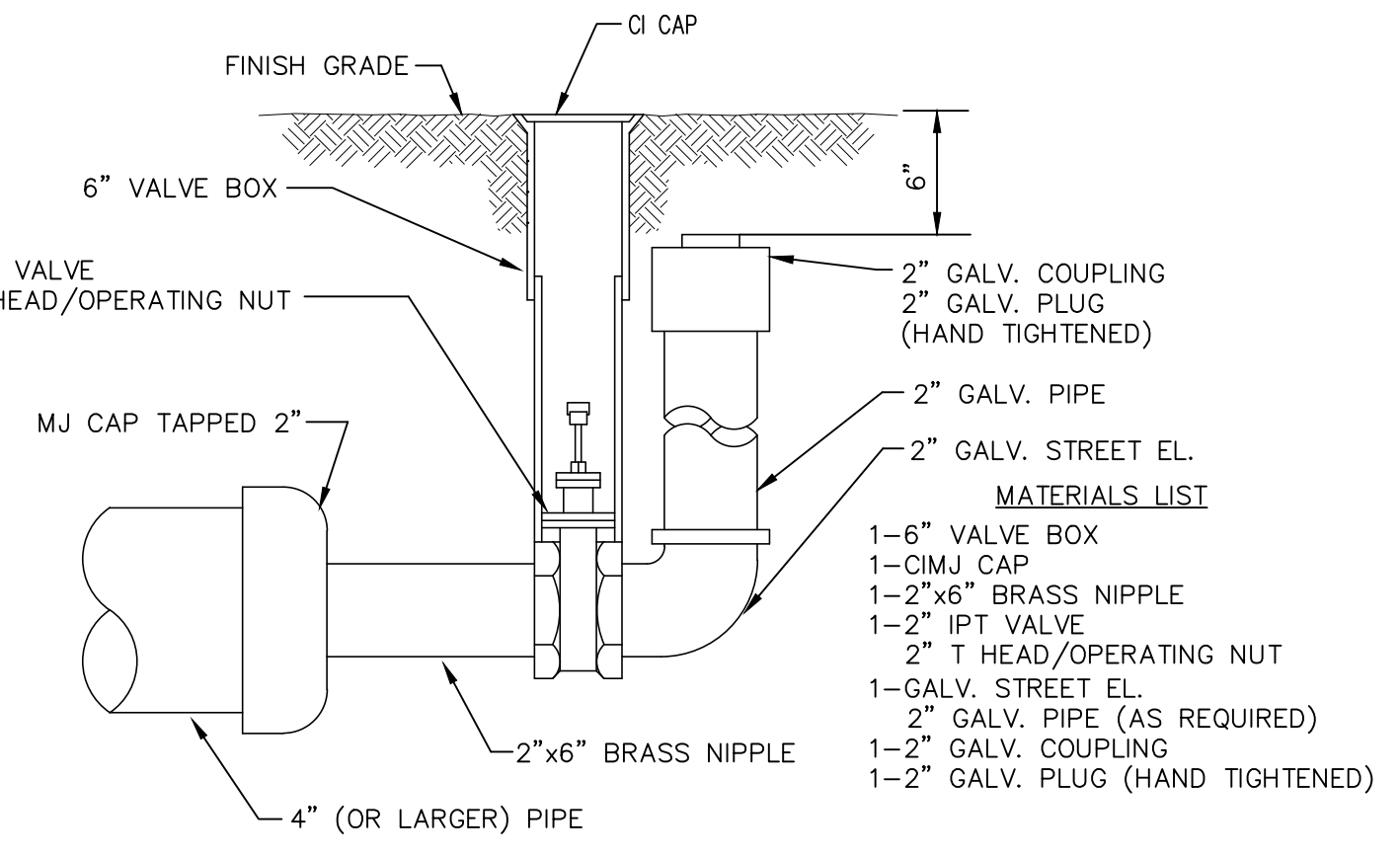

THRUST AT VALVES

VALVE	THRUST AT 150 #/sq in
4"	1809 lbs.
6"	4245 lbs.
8"	7540 lbs.
12"	16965 lbs.

- Notes:**
- Concrete Block at Valve to have sufficient bearing in undisturbed soil to prevent thrust movement as shown in table at right. Field Engineer to determine thrust loading of undisturbed soil and final size of thrust block.
 - The thrust block shall be constructed such that bolts, nuts, and other MJ accessories are kept clear of concrete.
 - All valves at dead ends and at other locations as called out on the plans shall be blocked as shown here.

ANCHORED VALVE ASSEMBLY, SPECIAL



STANDARD WATER ASSEMBLY DETAIL
INTERIM CITY ENGINEER
GARY JANZEN, P.E.

PROJECT NUMBER	OCA NUMBER	DATE
		12/2011

CITY ENGINEER'S OFFICE
CITY HALL - SEVENTH FLOOR
455 NORTH MAIN STREET
WICHITA, KANSAS 67202-1620
(316) 268-4501

AAA MINI STORAGE
530 EAST MACARTHUR ROAD
WATER DISTRIBUTION SYSTEM IMPROVEMENTS
STANDARD WATER DETAILS
CITY OF WICHITA, KANSAS
GARY JANZEN, P.E. - INTERIM CITY ENGINEER
C.O.# XXX-XXXX O.C.# XXXXXX

POE & ASSOCIATES, INC.
CONSULTING ENGINEERS
5940 E. Central, Suite 200 Wichita, KS
67208-0242
Phone 316/685-4114 FAX 316/685-4444

REGISTERED PROFESSIONAL ENGINEER
KANSAS
17874

Engineer: S. SERVIS
Designer: S. SERVIS
Drawing: P:\1109P\AAA_STORAGE\BoseWL.dwg
Date: 9/25/2012

Sheet 2 of 10

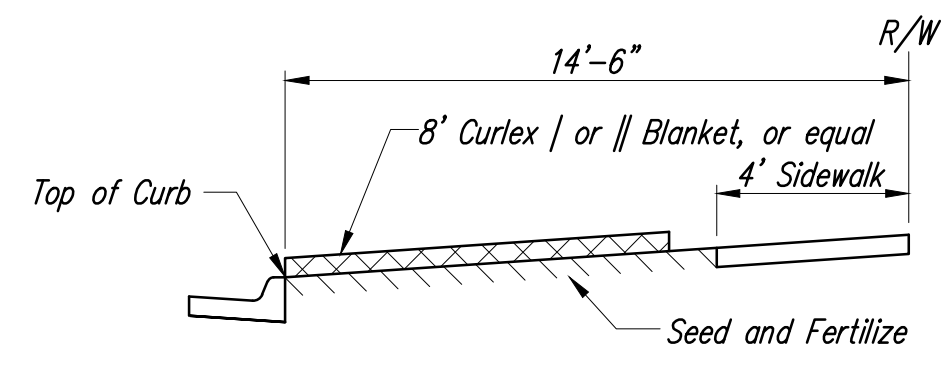

SECTION B-B

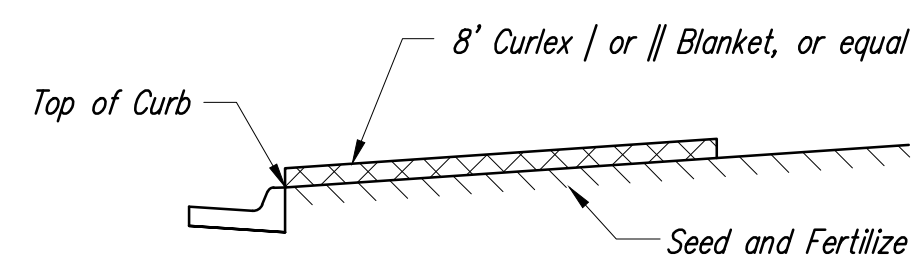

SECTION A-A

Install 8' wide Curlex | or || Excelsior Blanket, or equal, on prepared surface back of curb. Edge of blanket will be at back of curb. Install per manufacturer's recommendation, including staples. (See detail)

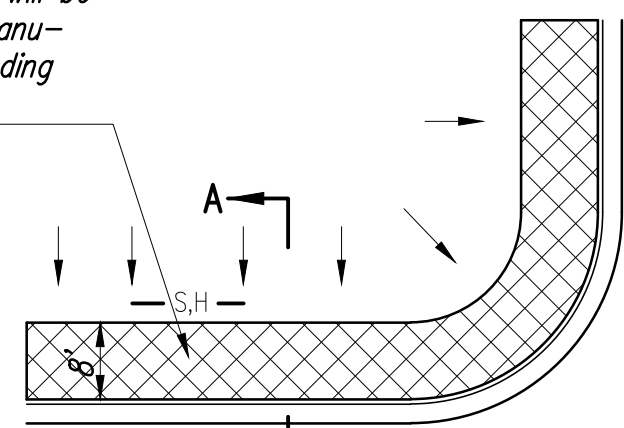

SOUTH STREET

Install 8' wide Curlex | or || Excelsior Blanket, or equal, on prepared surface back of curb. Edge of blanket will be at back of curb. Install per manufacturer's recommendation, including staples. (See detail)

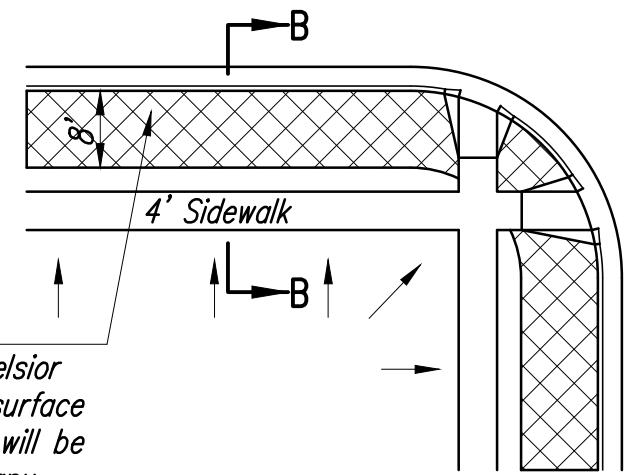

- NOTES:
- EXCELSIOR MAT TO BE INSTALLED WHEN SOD IS NOT SPECIFIED ON PROJECT.
 - EXCELSIOR BLANKET TO BE INSTALLED OVER SEED AND FERTILIZER, AS SPECIFIED IN THE PROJECT SPECIFICATIONS.
 - AFTER INSTALLATION OF EXCELSIOR BLANKET, AT LOCATIONS WHERE CONCENTRATED FLOW CARRIES SEDIMENT OVER THE CURB AND INTO THE GUTTER, SUPPLEMENTAL EROSION CONTROL DEVICES WILL BE INSTALLED BY THE CONTRACTOR AS NEEDED, TO FIX THE PROBLEM.

BACK OF CURB PROTECTION DETAIL

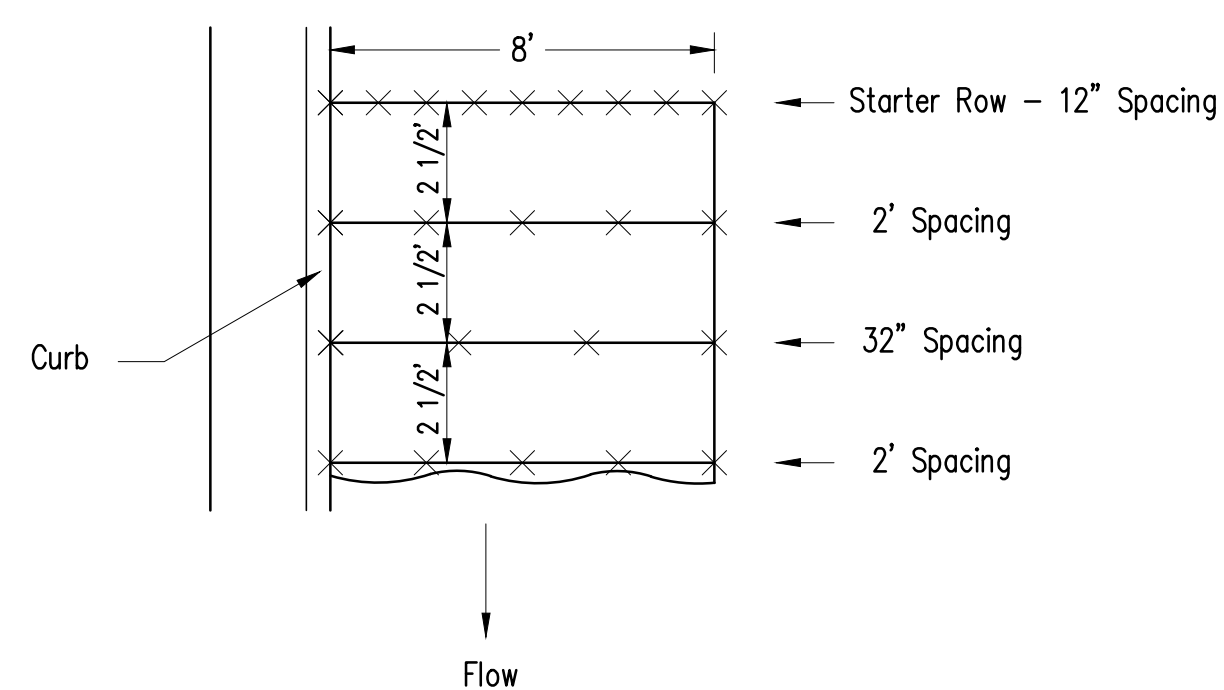

STAPLE PATTERN

NOTES: Use 6" seam overlap

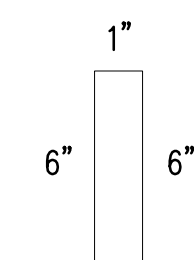

11 ga. Wire

STAPLE

DETAILS FOR CURLEX | OR || BLANKETS

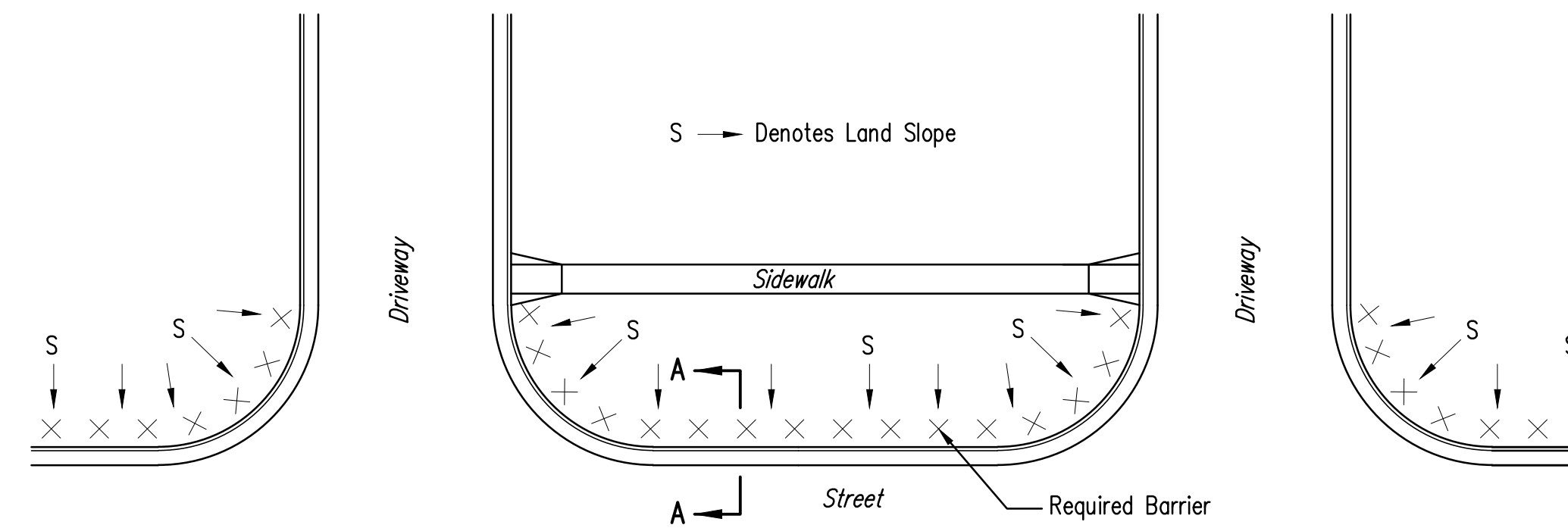

PLAN VIEW

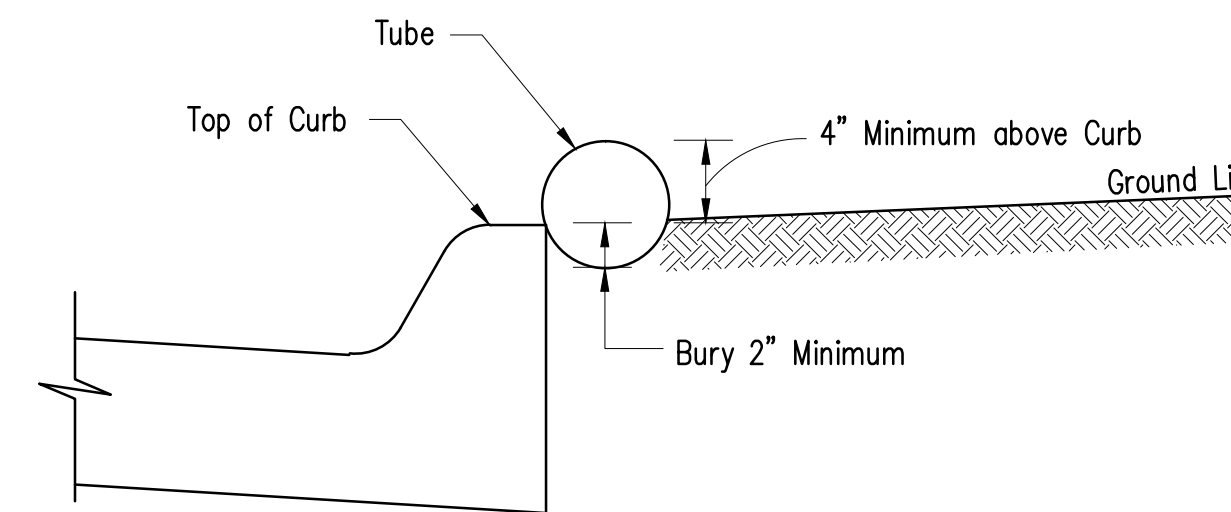

SECTION A-A

- NOTES:
- Barriers must be placed back of curb along street and up the driveway sufficiently to catch all sediment from the yard.
 - Overlap seams 6 inches
 - Anchor to ground every 3.0 feet.
 - All tubes shall be constructed of heavy duty netting, rolled erosion control fabric or similar devices filled with a porous material that will allow water to pass while filtering sediment. Tubes shall be 6" to 9" in diameter.
 - Remove accumulated sediment when within 2 inches of top of device.
 - Replace all broken tubes to maintain effectiveness of device.
 - If tubes are removed during the day for access to the site, they will be replaced prior to a rainfall event and at night before work ceases. Replace properly per original design.

TUBE BARRIERS

NOTES:
Properly constructed and maintained Silt Fence Barriers or Straw Bale Barriers may be used for back of curb erosion control. See the Soil Erosion BMPs-Barrier Details for additional information.

No.	Date	By	Approved	Revision

AAA MINI STORAGE
530 EAST MACARTHUR ROAD
WATER DISTRIBUTION SYSTEM IMPROVEMENTS
EROSION CONTROL DETAIL
CITY OF WICHITA, KANSAS
GARY JANZEN, P.E. - INTERIM CITY ENGINEER
C.O.W. Proj# XXX-XXXX O.C.# XXXXX

POE & ASSOCIATES, INC.
CONSULTING ENGINEERS
5940 E. Central, Suite 200 Wichita, KS
67208-4242
Phone 316/685-4444 FAX 316/685-4444

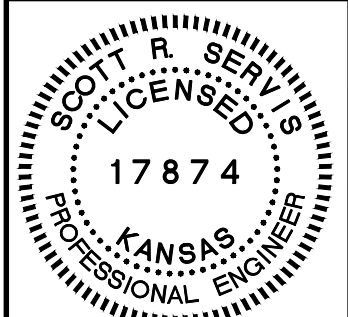
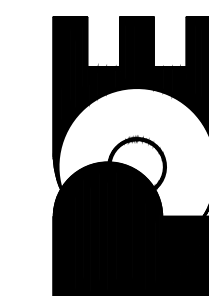

FINAL
Engineer: S. SERVIS
Designer: S. SERVIS
Drawing: P:\1109P\AAA STORAGE\BoseWL.dwg
Date: 9/25/2012

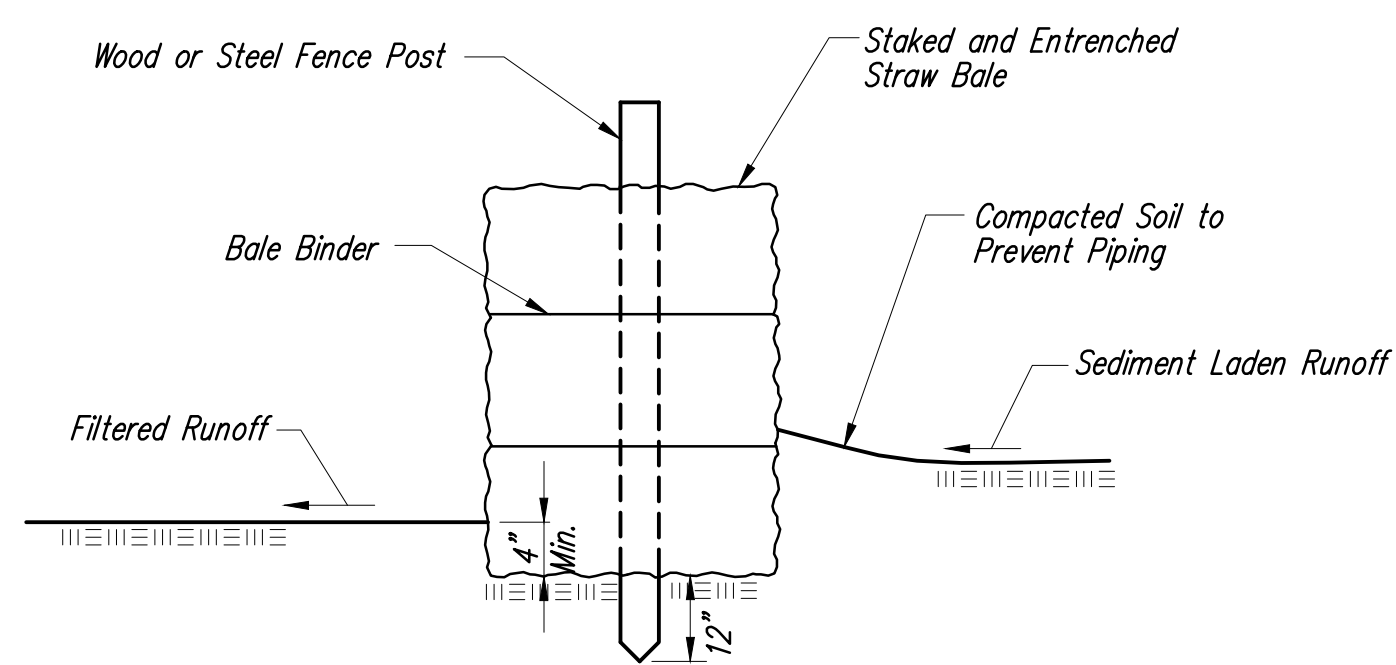

STRAW BALE BARRIERS

Material Specification:

Bale slope barriers may be constructed of wheat straw, oat straw, prairie hay, or bromegrass hay that is free of weeds declared noxious by the Kansas State Board of Agriculture. The stakes used to anchor the bales should be a hardwood material with the following minimum dimensions: 2" square (nominal) by 4' long. Twine should be used to bind bales. The use of wire binding is prohibited because it does not biodegrade readily.

Placement:

A slope barrier should be used at the toe of a slope when a ditch does not exist. The slope barrier should be placed on nearly level ground 5' to 10' away from the toe of a slope. The barrier is placed away from the toe of the slope to provide adequate storage for settling out sediment.

When practicable, bale slope barriers should be placed along contours to avoid a concentration of flow.

Bale slope barriers can also be placed along right-of-way fence lines to keep sediment from crossing onto adjacent property. When placed in this manner, the slope barrier will not likely follow contours.

Proper installation method:

Excavate a trench the length of the planned slope barrier that is 4" deep and a bale's width wide. Make sure that the trench is excavated along a single contour. When practicable, slope barriers should be placed along contours to avoid a concentration of flow. Place the soil on the upslope side of the trench for later use.

Place the bales in the trench, making sure that they are butted tightly. Two stakes should be driven through each bale along the centerline of the ditch check, approximately 6" to 8" in from the bale ends. Stakes should be driven at least 12" into the ground.

Once all the bales have been installed and anchored, place the excavated soil against the upslope side of the check and compact it. The compacted soil should be no more than 3" to 4" deep.

List of common placement/installation mistakes to avoid:

When practical, do not place bale slope barriers across contours. Slope barriers should be placed along contours to avoid a concentration of flow. Concentrated flow over a slope barrier creates a scour hole on the downslope side of the barrier. The scour hole eventually undermines the bales and the barrier fails.

Do not place bale slope barriers in areas with shallow soils underlain by rock. If the barrier is not anchored sufficiently, it will wash out.

Bale slope barriers must be dug into the ground. Bales at ground level do not work because they allow water to flow under the barrier.

Inspection and Maintenance:

Bale slope barriers should be inspected every 7 days and within 24 hours of a rainfall of 1/2" or more. The following is a list of questions that should be addressed during each inspection:

- Are there any points along the slope barrier where water is concentrating?
- Does water flow under the slope barrier?
- Does water flow through spaces between abutting bales?
- Are any bales dislodged?
- Are bales decomposing due to age and/or water damage?
- Does sediment need to be removed from behind the slope barrier?

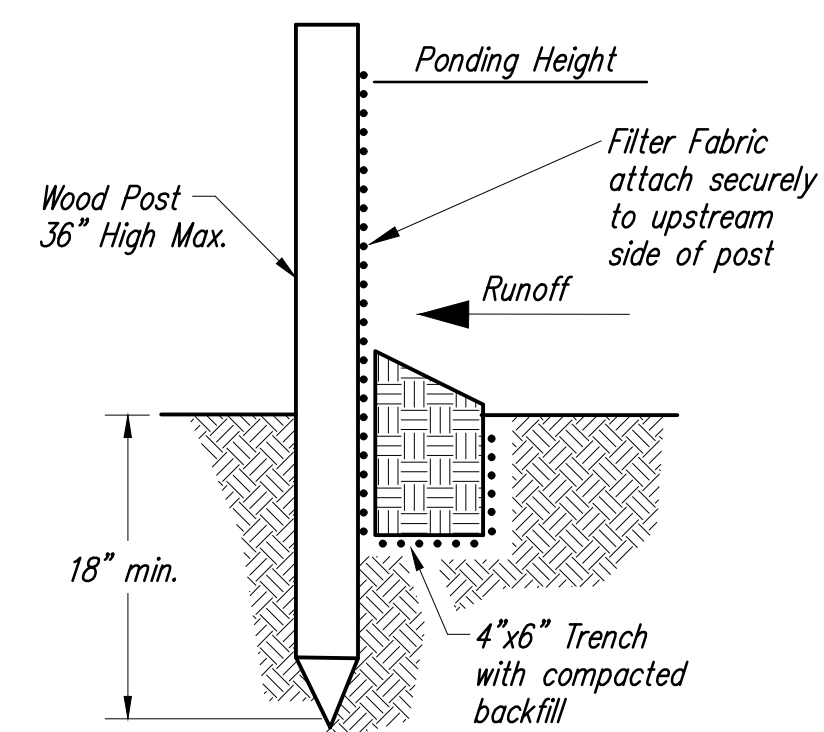

SILT FENCE BARRIERS

Material Specification:

Silt fence fabric should conform to the AASHTO M288 96 silt fence specification. The posts used to support the silt fence fabric should be a hardwood material with the following minimum dimensions: 2" square (nominal) by 4' long. Silt fence fabric should be attached to the wooden posts with staples, wire, zip ties, or nails.

Placement:

A slope barrier should be used at the toe of a slope when a ditch does not exist. The slope barrier should be placed on nearly level ground 5' to 10' away from the toe of a slope. The barrier is placed away from the toe of the slope to provide adequate storage for settling out sediment.

When practicable, silt fence slope barriers should be placed along contours to avoid a concentration of flow.

Silt fence slope barriers can also be placed along right-of-way fence lines to keep sediment from crossing onto adjacent property. When placed in this manner, the slope barrier will not likely follow contours.

Proper installation method:

Excavate a trench the length of the planned slope barrier that is 6" deep by 4" wide. Make sure that the trench is excavated along a single contour. When practicable, slope barriers should be placed along contours to avoid a concentration of flow. Place the soil on the upslope side of the trench for later use.

Roll out a continuous length of silt fence fabric on the downslope side of the trench. Place the edge of the fabric in the trench starting at the top upslope edge. Line all three sides of the trench with the fabric. Backfill over the fabric in the trench with the excavated soil and compact. After filling the trench, approximately 24" to 36" of silt-fence fabric should remain exposed.

Lay the exposed silt fence upslope of the trench to clear an area for driving in the posts. Just downslope of the trench, drive posts into the ground to a depth of at least 18". Place posts no more than 4' apart.

Attach the silt fence to the anchored post with staples, wire, zip ties, or nails.

List of common placement/installation mistakes to avoid:

When practicable, do not place silt fence slope barriers across contours. Slope barriers should be placed along contours to avoid a concentration of flow. When the flow concentrates, it overtops the barrier and the silt fence slope barrier quickly deteriorates.

Do not place silt-fence posts on the upslope side of the silt fence fabric. In this configuration, the force of the water is not restricted by the posts, but only by the staples (wire, zip ties, nails, etc.). The silt fence will rip and fail.

Do not place silt fence slope barriers in areas with shallow soils underlain by rock. If the barrier is not sufficiently anchored, it will wash out.

Silt fence slope barriers must be dug into the ground—silt fence at ground level does not work because water will flow underneath.

Inspection and Maintenance:

Silt fence slope barriers should be inspected every 7 days and within 24 hours of a rainfall of 1/2" or more. The following is a list of questions that should be addressed during each inspection:

- Are there any points along the slope barrier where water is concentrating?
- Does water flow under the slope barrier?
- Do the silt fences sag excessively?
- Has the silt fence torn or become detached from the posts?
- Does sediment need to be removed from behind the slope barrier?

No.	Date	By	Approved	Revision

AAA MINI STORAGE
530 EAST MACARTHUR ROAD
WATER DISTRIBUTION SYSTEM IMPROVEMENTS
EROSION CONTROL DETAIL
CITY OF WICHITA, KANSAS
GARY JANZEN, P.E. - INTERIM CITY ENGINEER
C.O.W. Proj# XXX-XXXX O.C.A.# XXXXX

POE & ASSOCIATES, INC.
CONSULTING ENGINEERS
5940 E. Central, Suite 200 Wichita, KS
67208-0242
Phone 316/685-4444
FAX 316/685-4444

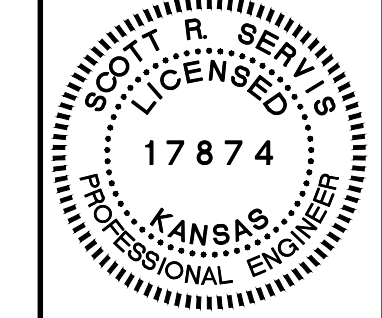
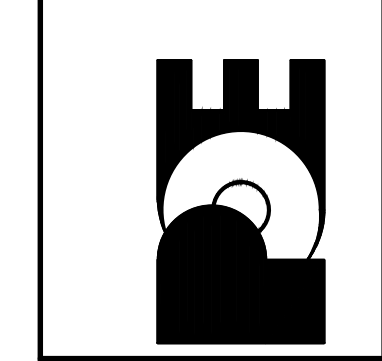

FINAL
Engineer: S. SERVIS
Designer: S. SERVIS
Drawing: P:\1109P\AAA STORAGE\BoseW.L.dwg
Date: 9/25/2012

GENERAL NOTES

1. THIS SHEET IS INTENDED TO PROVIDE GUIDELINES AS TO WHAT TYPES OF EROSION CONTROL DEVICES WILL BE INSTALLED DURING THE CONSTRUCTION PROCESS. CONTRACTORS ARE EXPECTED TO BID PROJECTS ACCORDINGLY.
2. EROSION CONTROL DEVICES MUST BE MAINTAINED BY THE CONTRACTOR THROUGHOUT THE CONSTRUCTION PROCESS AND UNTIL THE DISTURBED EARTH IS RESTABILIZED.
3. IF THE PROJECT WILL DISTURB 1 ACRE OR MORE, A FEDERAL/STATE NPDES STORMWATER PERMIT IS REQUIRED. A DETAILED STORMWATER POLLUTION PREVENTION PLAN, IS REQUIRED. THE EROSION CONTROL DEVICES SHOWN ON THIS SHEET ARE CONSIDERED TO BE THE MINIMUM TO BE SHOWN IN THE POLLUTION PREVENTION PLAN.
4. FOR PROJECTS DISTURBING LESS THAN 1 ACRE, CONTRACTORS ARE ENCOURAGED TO PREPARE STORMWATER POLLUTION PREVENTION PLANS PRIOR TO CONSTRUCTION. EROSION CONTROL DEVICES MUST BE USED ON ALL PROJECTS.
5. FAILURE TO USE AND MAINTAIN EROSION CONTROL DEVICES IS A VIOLATION OF SECTION 16.32 OF THE CITY CODE AND WILL SUBJECT THE CONTRACTOR TO THE PENALTIES PROVIDED FOR THEREIN.
6. THE APPLICATION OF EROSION CONTROL DEVICES SHOWN ON THIS SHEET IS FOR SITUATIONS NORMALLY ENCOUNTERED. FROM TIME TO TIME, SITUATIONS WILL ARISE THAT MAY REQUIRE A DIFFERENT DEVICE OTHER THAN THOSE SHOWN. EROSION CONTROL DEVICES, OTHER THAN THOSE SHOWN, MAY BE UTILIZED AS LONG AS THEY ARE EFFECTIVE AND MAINTAINED.

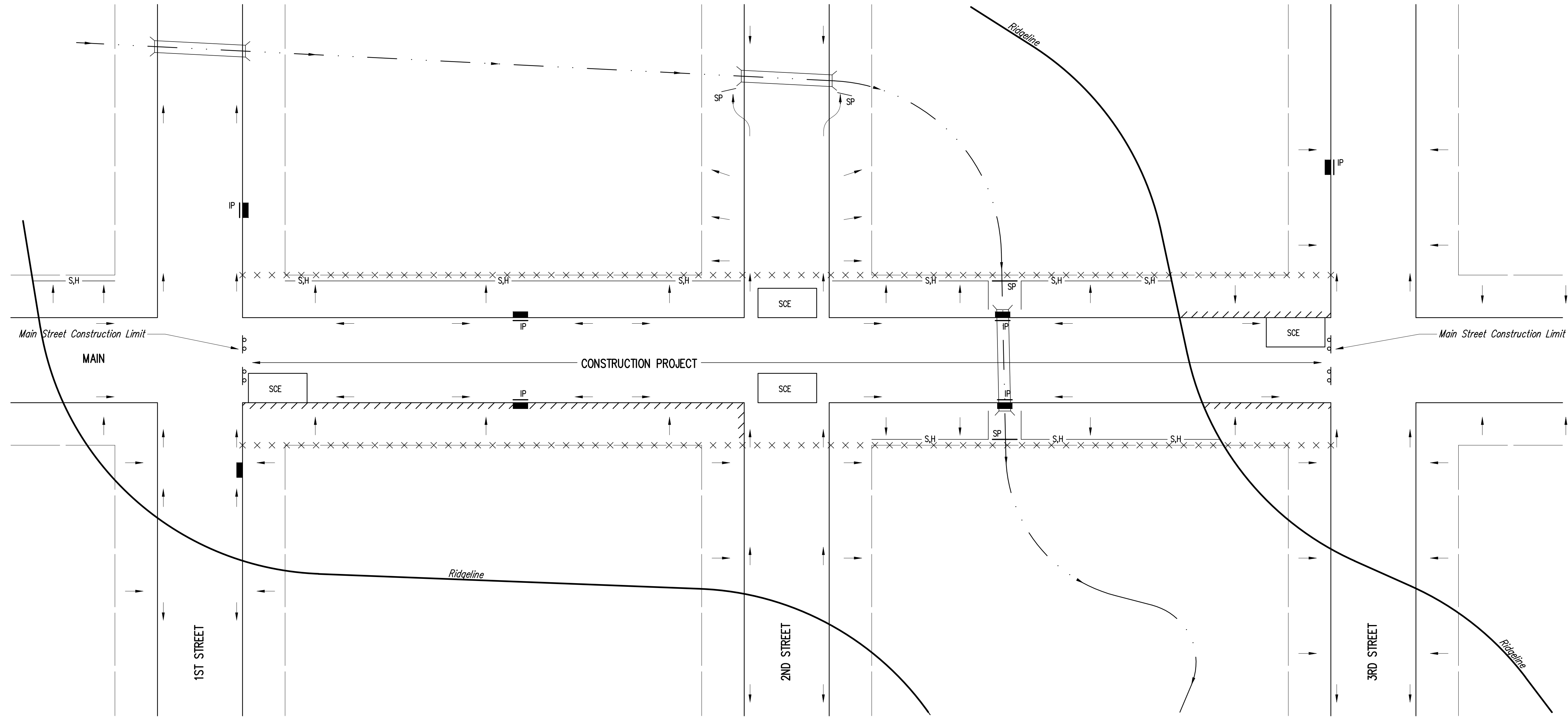

LEGEND

--- ---	R-O-W LIMITS
→	DRAINAGE FLOW PATH
× × × × ×	R/W LIMIT WITHIN CONSTRUCTION LIMIT
■	STORM WATER INLETS
IP	INLET PROTECTION
—S.H.—	SILT FENCE OR HAY BALE BARRIER
—S.P.—	STREAM PROTECTION
□ SCE	STABILIZED CONSTRUCTION ENTRANCE
////	BACK OF CURB PROTECTION

NOTES:

1. THE INTENT OF ALL EROSION CONTROL DEVICES IS TO KEEP ALL SEDIMENT CONFINED TO THE CONSTRUCTION SITE, AND OUT OF ALL UNDERGROUND PIPES, DITCHES, LAKES, AND OTHER DRAINAGE FACILITIES, AND OFF OF STREETS.
2. THE POINT OF COMPLIANCE IS GENERALLY THE RIGHT-OF-WAY LINES WITHIN THE LIMITS OF CONSTRUCTION.
3. EROSION CONTROL DEVICES WILL BE REQUIRED AT ALL POINTS ALONG THE PROJECT WHERE DISTURBED EARTH CAN DRAIN ONTO PRIVATE PROPERTY.
4. INLET PROTECTION DEVICES WILL BE REQUIRED WHEREVER WATER CAN DRAIN OFF THE PROJECT SITE INTO AN INLET, INCLUDING ANY SIDE STREET INLETS.
5. EROSION CONTROL DEVICES SHALL BE INSTALLED AT CREEK CROSSINGS SO AS TO PREVENT SEDIMENT FROM ENTERING THEREIN.
6. STABILIZED CONSTRUCTION ENTRANCES SHALL BE PROVIDED, AS NEEDED, TO PREVENT MUD FROM TRACKING ONTO STREETS NOT UNDER CONSTRUCTION AND ON STREETS WITHIN THE PROJECT LIMITS IF TRAFFIC IS BEING MAINTAINED THROUGH THE PROJECT.
7. ANY MUD TRACKED ONTO STREETS MUST BE REMOVED AT THE END OF EACH WORK DAY.
8. THE CONTRACTOR WILL BE REQUIRED TO PLACE EROSION CONTROL DEVICES BACK OF CURB, WHENEVER WATER CAN DRAIN OVER CURB, TO KEEP ERODED SOIL OUT OF THE GUTTERLINES, IN ACCORDANCE WITH THE FOLLOWING:
 - A. THE DEVICE REQUIRED WILL BE CURLEX | OR || EXCELSIOR BLANKET, OR EQUAL. SAID BLANKET SHALL BE PLACED OVER THE APPROPRIATE SEED AND FERTILIZER, AS SPECIFIED IN THE PROJECT SPECIFICATIONS. (SEE SOIL EROSION BMPs - BACK OF CURB SEDIMENT BARRIER DETAILS)
 - B. THIS DEVICE SHALL BE INSTALLED IMMEDIATELY WHENEVER THE CURB IS BACKFILLED TO WITHIN 3" OF THE TOP OF CURB. (SEE CURB BACKFILL DETAIL) OTHER BMP'S MAY BE REQUIRED AT LOCATIONS WHERE CONCENTRATED FLOW CARRIES SEDIMENT OVER THE CURB.
 - C. ADDITIONALLY, OTHER EROSION CONTROL DEVICES (HAY BALES, SILT FENCE, ETC.) WILL BE INSTALLED AT LOCATIONS OF CONCENTRATED FLOW RESULTING IN SEDIMENT OVERRUNNING THE MAT.
 - D. SHOULD THE PROJECT PLANS SPECIFY THAT THE RIGHT-OF-WAY IS TO BE SODDED, THE EXCELSIOR MAT WILL NOT BE REQUIRED SO LONG AS THE SOD IS PLACED WITHIN 48 HOURS AFTER CURB BACKFILL REACHES A HEIGHT OF 3" OR LESS FROM TOP OF CURB. (SEE CURB BACKFILL DETAIL)

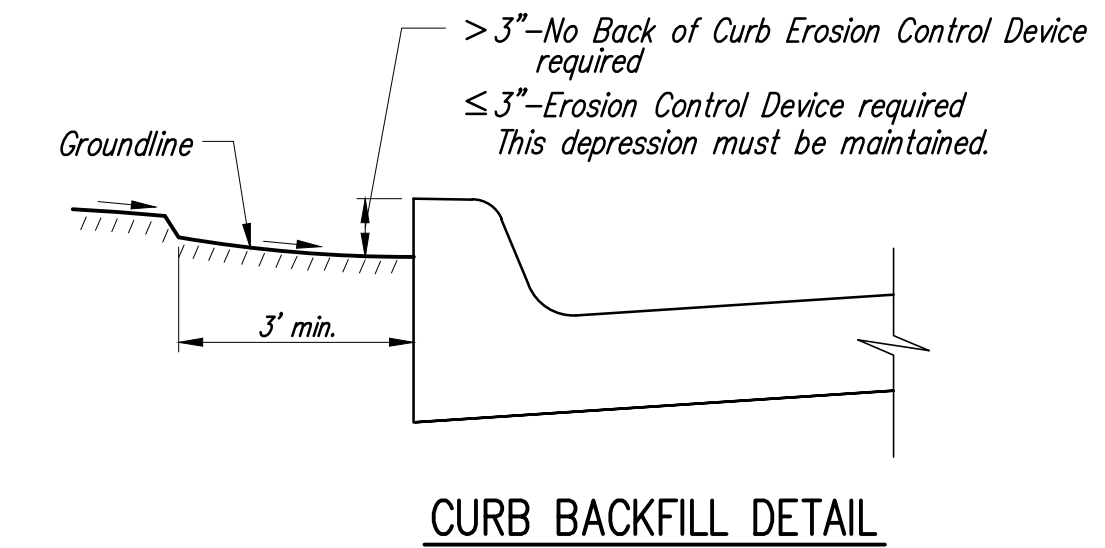

AAA MINI STORAGE 530 EAST MACARTHUR ROAD WATER DISTRIBUTION SYSTEM IMPROVEMENTS EROSION CONTROL DETAIL CITY OF WICHITA, KANSAS GARY JANZEN, P.E. - INTERIM CITY ENGINEER C.O.W. Proj# XXX-XXXX O.C.A.# XXXXXX	POE & ASSOCIATES, INC. CONSULTING ENGINEERS 5940 E. Central, Suite 200 Wichita, KS 67208-0242 Phone 316(685-4114 FAX 316(685-4444)		FINAL Engineer: S. SERVIS Designer: S. SERVIS Drawing: P:\1109P\AAA STORAGE\BoseWL.dwg Date: 9/25/2012
No.	Date	By	Approved/Revision

PHASE 1 – INITIAL EARTHWORK AND UTILITIES (EXCEPT STORM SEWER)

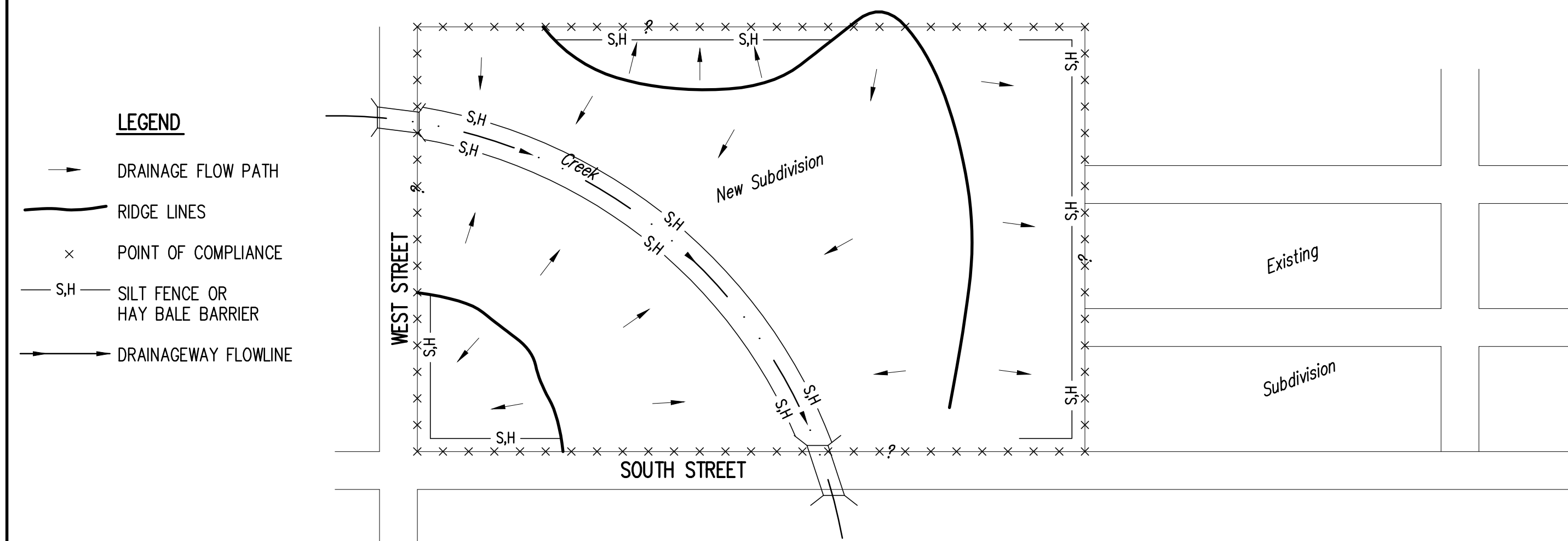

- DURING THIS PHASE OF SUBDIVISION CONSTRUCTION, THE POINTS OF COMPLIANCE ARE THE PERIMETER BOUNDARIES AND ANY DRAINAGE WAYS OR STORM SEWERS DRAINING THROUGH OR FROM THE SITE. SHOULD LAKES BE CONSTRUCTED WITHIN THE SUBDIVISION THAT WILL DISCHARGE DURING STORMS, THEY ARE ALSO A POINT OF COMPLIANCE.
- HAY BALES OR SILT FENCE MUST BE CONSTRUCTED ALONG THE PROPERTY LINE WHERE ON SITE WATER CAN DRAIN OFF THE PROPERTY. THESE EROSION CONTROL DEVICES WILL ALSO BE INSTALLED ALONG ANY DRAINAGE DITCH OR LAKE THAT CAN DISCHARGE.
- SHOULD SILT OR SEDIMENT ENTER THE DITCHES OR STREETS ON THE ADJACENT BOUNDARY STREETS, APPROPRIATE EROSION CONTROL DEVICES WILL BE PLACED WITHIN THE SUBDIVISION TO PREVENT THIS.
- ANY MUD TRACKED ONTO ADJACENT STREETS WILL BE REMOVED WITHIN 48 HOURS OR BY FRIDAY AT 6:00 PM, WHICHEVER IS EARLIER.
- CONTRACTORS WORKING WITHIN THE SITE WILL NOT BE REQUIRED TO USE INDIVIDUAL EROSION CONTROL DEVICES AS LONG AS THOSE SPECIFIED ABOVE ARE IN PLACE AND EFFECTIVE. CONTRACTORS WORKING ON THE BOUNDARY LINE STREETS OR ON ADJACENT PROPERTIES TO EXTEND UTILITIES ARE EXPECTED TO USE EROSION CONTROL DEVICES AT THEIR WORK LOCATIONS, AS NEEDED.
- UTILIZE STABILIZED CONSTRUCTION ENTRANCE AT ENTRANCE AND EXIT ONTO ANY EXISTING PUBLIC STREETS.
- IF THE INITIAL EARTH WORK AND UTILITIES ARE DONE AS PART OF A PUBLIC IMPROVEMENT PROJECT, THESE EROSION CONTROL DEVICES WILL BE INSTALLED BY THE CONTRACTOR AS SPECIFIED IN THE INDIVIDUAL PROJECT CONTRACTS. THE CONTRACTOR WILL MAINTAIN THE DEVICES UNTIL COMPLETION OF THE CONTRACT, AT WHICH TIME THE DEVELOPER WILL ASSUME MAINTENANCE RESPONSIBILITIES. IF THESE CONTRACTS ARE NOT PUBLIC IMPROVEMENT PROJECTS, THE DEVELOPER WILL BE RESPONSIBLE FOR INSTALLING AND MAINTAINING THESE DEVICES.
- WITHIN 14 DAYS OF COMPLETION OF EARTHWORK ACTIVITIES IN ANY GIVEN AREA, THAT AREA SHALL BE TEMPORARILY OR PERMANENTLY SEEDED AND MULCHED.

PHASE 3 – STREET CONSTRUCTION

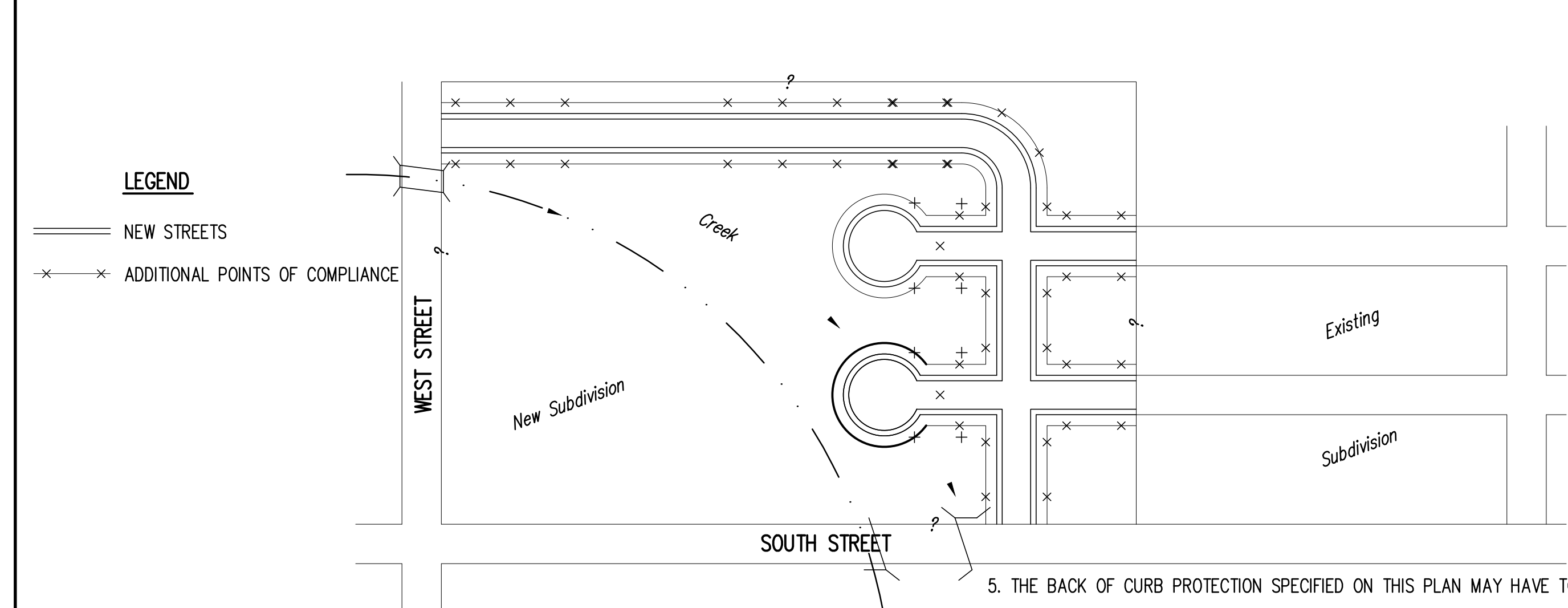

- DURING THIS PHASE OF SUBDIVISION CONSTRUCTION, NEW STREETS ARE INSTALLED. ALL EROSION CONTROL DEVICES INSTALLED DURING PHASE 1 AND 2 MUST STILL BE MAINTAINED. THE POINT OF COMPLIANCE NOW SHIFTS TO THE BACK OF CURB ALONG EACH STREET.
- CURB OPENING INLET PROTECTION:
 - SUMP AREAS – INLET PROTECTION SHALL BE PROVIDED WHEN STREET SUBGRADE WORK IS COMPLETED.
 - NON-SUMP LOCATIONS – PROVIDE INLET PROTECTION AS SOON AS BASE COURSE ASPHALT IS INSTALLED, BEFORE THE SURFACE COURSE LIFT.
- EROSION CONTROL DEVICES WILL BE REQUIRED BACK OF CURB WHEREVER WATER CAN FLOW OVER THE CURB AND THE CURB HAS BEEN BACKFILLED TO WITHIN 3" OR LESS OF THE TOP OF CURB (SEE CURB BACKFILL DETAIL). FOR CURBS NOT YET ENTIRELY BACKFILLED (3" OR MORE BELOW TOP OF CURB), ADDITIONAL DEVICES WILL BE REQUIRED AT POINTS WHERE WATER BREAKS OVER CURB WHICH COULD RESULT IN THE PLACEMENT OF SEDIMENT IN THE GUTTER.
- SEE DETAIL SHEET FOR BACK OF CURB PROTECTION.

SUPPLEMENTED WITH HAY BALE OR SILT FENCE EROSION CONTROL DEVICES AT LOCATIONS WHERE CONCENTRATED FLOW RESULTS IN SEDIMENT BEING CARRIED OVER THE EXCELSIOR MATS.
- THE STREET CONTRACTOR WILL BE RESPONSIBLE FOR INSTALLING BACK OF CURB EROSION CONTROL DEVICES.

THE SUBDIVISION DEVELOPER WILL BE RESPONSIBLE FOR STABILIZING BACK OF CURB WITH GRASS OR SOD.
- THE INDIVIDUAL LOT OWNERS WILL BE RESPONSIBLE FOR MAINTAINING THE BACK OF CURB EROSION CONTROL DEVICES IN FRONT OF THEIR LOTS UNTIL

PHASE 2 – INSTALLATION OF STORM SEWER

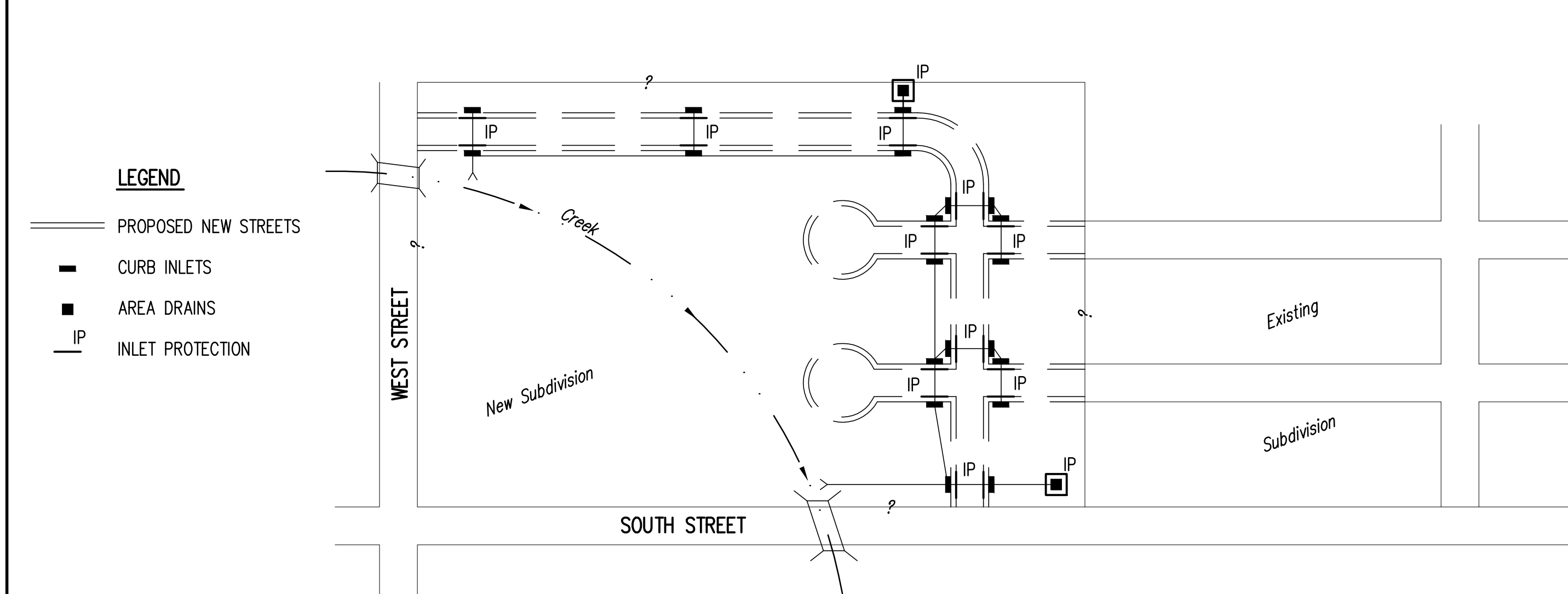

- DURING THIS PHASE OF SUBDIVISION DEVELOPMENT, ALL EROSION CONTROL DEVICES REQUIRED IN PHASE 1 SHALL REMAIN IN PLACE AND BE MAINTAINED.
- AS NEW STORM SEWERS, WITH INLETS, ARE INSTALLED, THE STORM SEWERS MUST NOW BE PROTECTED SO ALL NEW INLETS BECOME POINTS OF COMPLIANCE.
- AREA DRAINS – AS SOON AS WATER CAN FLOW INTO THESE DRAINS, HAY BALE OR SILT FENCE PROTECTION WILL BE INSTALLED AROUND THEM.
- CURB OPENING INLETS – AS SOON AS WATER CAN FLOW INTO THESE DRAINS, INLET PROTECTION DEVICES MUST BE INSTALLED. IF WATER CANNOT FLOW INTO CURB INLETS UNTIL STREET CONSTRUCTION IS COMPLETE, THEN STREET CONTRACTOR WILL INSTALL INLET PROTECTION. SEE PHASE 3 – STREET CONSTRUCTION.
- THE STORM SEWER CONTRACTOR WILL BE RESPONSIBLE FOR INSTALLING THESE DEVICES.
- THE SUBDIVISION DEVELOPER WILL MAINTAIN THESE EROSION CONTROL DEVICES ONCE INSTALLED.
- ALL DISTURBED GROUND WILL BE FINAL GRADED AND TEMPORARILY OR PERMANENTLY SEEDED WITHIN 14 DAYS IF COMPLETION OF WORK IN ANY GIVEN PART OF THE SUBDIVISION.
- ONCE ALL DISTURBED GROUND DRAINING TO AN INLET HAS BEEN RESTABILIZED WITH GRASS OR SOD, THE SUBDIVISION DEVELOPER WILL BE RESPONSIBLE FOR PERMANENTLY REMOVING THE INLET PROTECTION.

GENERAL NOTES:

- THE INTENT OF ALL EROSION CONTROL DEVICES IS TO PREVENT ERODED SOIL FROM ENTERING DITCHES, STORM SEWERS, LAKES, STREETS OR ANY OTHER OTHER DRAINAGE FEATURE.
- THIS SHEET IS INTENDED TO PROVIDE GUIDELINES AS TO WHAT TYPE OF EROSION CONTROL DEVICES WILL BE INSTALLED DURING THE CONSTRUCTION PROCESS. CONTRACTORS ARE EXPECTED TO BID PROJECTS ACCORDINGLY.
- EROSION CONTROL DEVICES SHALL BE MAINTAINED DURING THE CONSTRUCTION PROCESS TO REMAIN EFFECTIVE. MAINTENANCE SHALL BE AS INDICATED ON SOIL EROSION BMP'S DETAIL SHEETS.
- PERSONS DESTROYING EROSION CONTROL DEVICES SHALL BE RESPONSIBLE FOR IMMEDIATELY REPAIRING THEM OR INSTALLING SUITABLE REPLACEMENT DEVICES.
- THE DEVELOPMENT OF ANY SUBDIVISION THAT DISTURBS 1 ACRE OR MORE WILL REQUIRE A FEDERAL/STATE NPDES STORMWATER PERMIT. THE PREPARATION OF A STORMWATER POLLUTION PREVENTION PLAN IS REQUIRED. EROSION CONTROL DEVICES ARE REQUIRED. THE DETAILS SHOWN ON THIS SHEET ARE THE MINIMUM STANDARDS TO BE SHOWN ON POLLUTION PREVENTION PLANS.
- FOR SUBDIVISIONS SMALLER THAN 1 ACRE, SOIL EROSION DEVICES ARE REQUIRED. ALSO, DEVELOPERS AND CONTRACTORS ARE ENCOURAGED TO DEVELOP POLLUTION PREVENTION PLANS FOR EACH PROJECT PRIOR TO CONSTRUCTION.
- FAILURE TO USE AND MAINTAIN SOIL EROSION DEVICES IS A VIOLATION OF SECTION 16.32 OF THE CITY CODE AND WILL SUBJECT THE SUBDIVISION DEVELOPER AND CONTRACTORS TO THE PENALTIES PROVIDED THEREIN.
- THE APPLICATION OF EROSION CONTROL DEVICES SHOWN ON THIS SHEET IS FOR SITUATIONS NORMALLY ENCOUNTERED. FROM TIME TO TIME, SITUATIONS WILL ARISE THAT MAY REQUIRE DEVICES OTHER THAN THAT SHOWN. EROSION CONTROL DEVICES, OTHER THAN THOSE SHOWN, MAY BE UTILIZED SO LONG AS THEY ARE EFFECTIVE AND MAINTAINED.
- A STABILIZED EARTH SURFACE IS DEFINED AS ONE THAT IS HARD SURFACED WITH CONCRETE, ASPHALT, OR THE LIKE, OR ONE ON WHICH 70% OF THE GRASS HAS GERMINATED ON THE ENTIRE SURFACE.

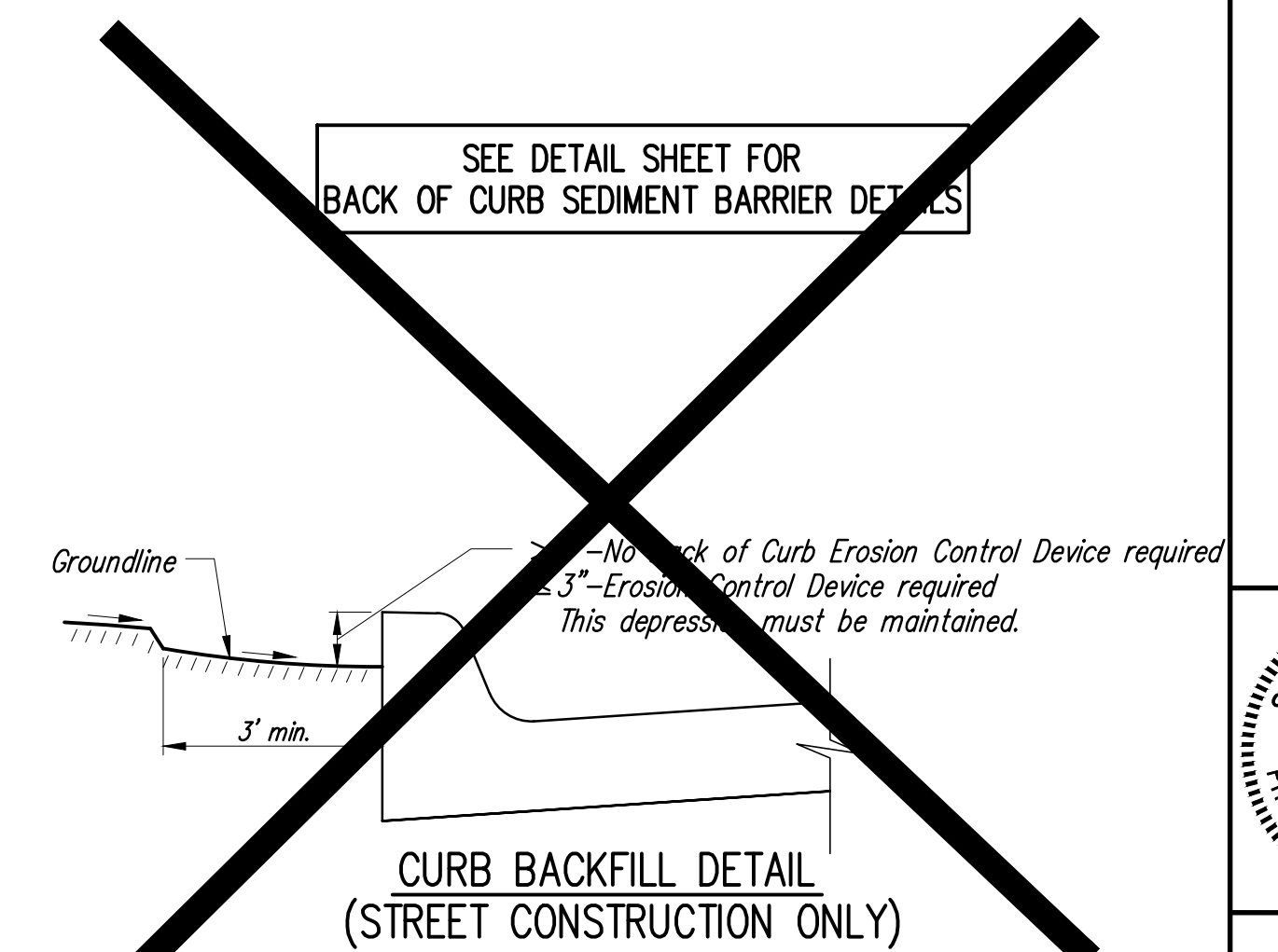

AAA MINI STORAGE 530 EAST MACARTHUR ROAD WATER DISTRIBUTION SYSTEM IMPROVEMENTS EROSION CONTROL DETAIL CITY OF WICHITA, KANSAS GARY JANZEN, P.E. - INTERIM CITY ENGINEER C.O.W. Proj# XXX-XXXX O.C.A.# XXXXXX	POE & ASSOCIATES, INC. CONSULTING ENGINEERS 5940 E. Central, Suite 200 Wichita, KS 67208-0242 Phone 316/685-4114 FAX 316/685-4444		FINAL Engineer: S. SERVIS Designer: S. SERVIS Drawing: P:\1109P\AAA STORAGE\BoseWL.dwg Date: 9/25/2012
Approved/Revision By Date No.	Sheet 9 of 10		

BARNUM ADDITION WICHITA, SEDGWICK COUNTY, KANSAS

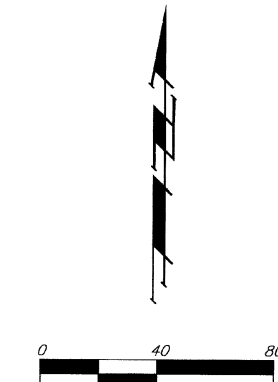
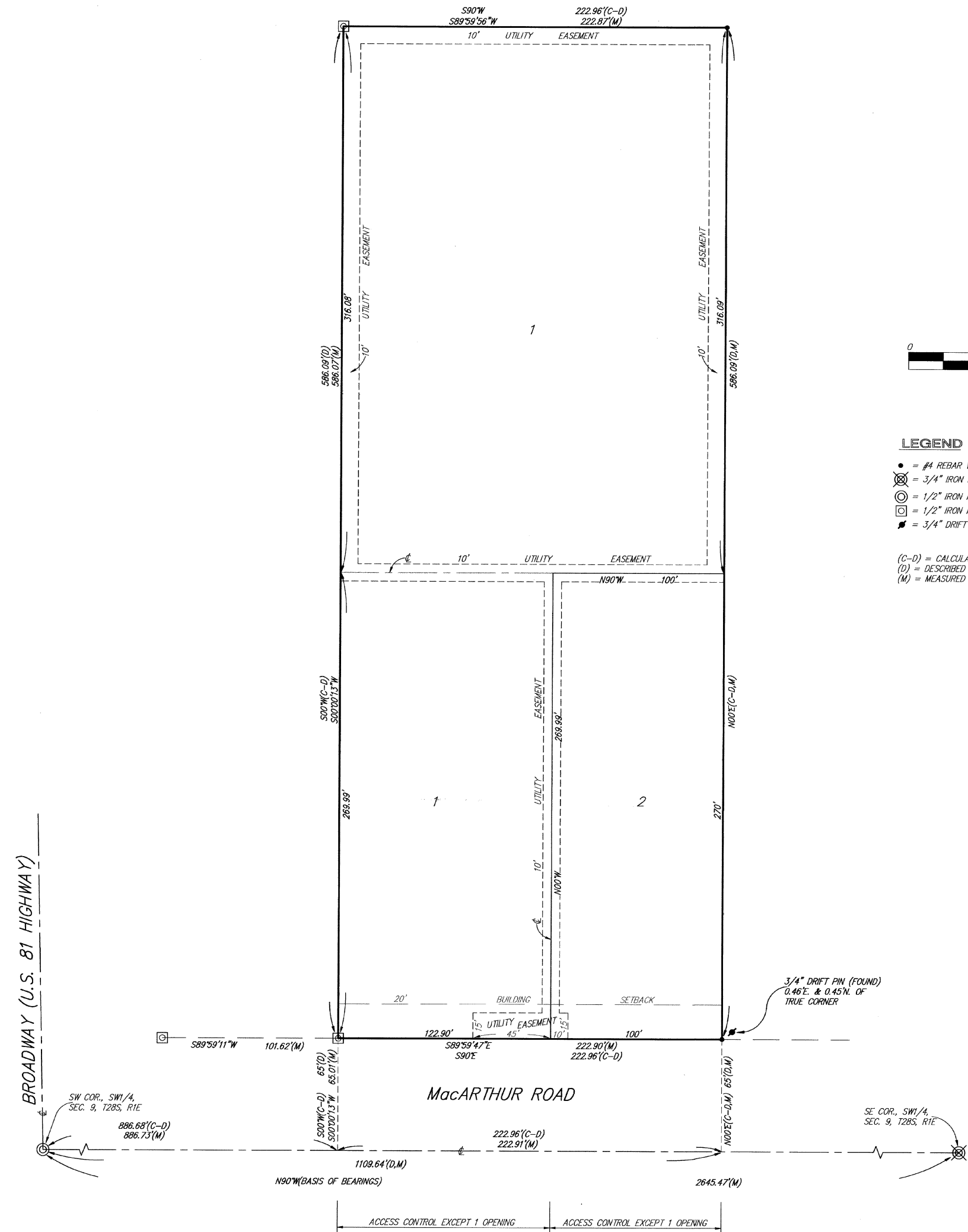

- LEGEND**
- = #1 REBAR W/ "BAUGHMAN" CAP (SET)
 - ⊗ = 3/4" IRON N. TRIMBLE (FOUND)
 - ⊙ = 1/2" IRON N. TRIMBLE (FOUND)
 - ⊚ = 1/2" IRON IN CONC. (FOUND)
 - = 3/4" DRIFT PIN (FOUND)
- (C)-(D) = CALCULATED PER DESCRIBED INFO
 (E) = DESIGNED
 (M) = MEASURED

State of Kansas) SS We, Baughman Company, P.A., Surveyors in Sedgwick County) do hereby certify that we have surveyed and plotted "BARNUM ADDITION", Wichita, Sedgwick County, Kansas, and that the accompanying plat is a true and correct exhibit of the property surveyed, described as follows: A tract in the SW 1/4 of Sec. 9, Tps. 28-S, R. 1-E of the 6th P.M., Sedgwick County, Kansas, described as follows: Beginning at a point 961 feet east and 65 feet north of the SW corner of said Sec. 9, said easterly distance being measured along the south line of said Sec. 9, and said northerly distance at right angles with the south line of said Sec. 9, thence north along a line at right angles with the south line of said Sec. 9, a distance of 586.09 feet, thence west parallel with the south line of said Sec. 9, a distance of 74.32 feet, thence south and parallel with the east line of said tract to a point 65 feet north of the south line of said Sec. 9, thence east along a line parallel with the south line of said Sec. 9, a distance of 74.32 feet to the point of beginning, TOGETHER with a tract described as beginning at a point 1103.64 feet east and 65 feet north of the SW corner of said Sec. 9, said easterly distance being measured along the south line of said Sec. 9, and said northerly distance at right angles with the south line of said Sec. 9, thence north along a line at right angles with the south line of said Sec. 9, a distance of 586.09 feet, thence west parallel with the south line of said Sec. 9, a distance of 148.64 feet, thence south along a line at right angles with the south line of said Sec. 9, a distance of 586.09 feet to a point 65 feet north of the south line of said Sec. 9, thence east 148.64 feet to the point of beginning.

Existing public easements and dedications being vacated by virtue of K.S.A. 12-512(b).
 Baughman Co., P.A.

Michael D. Conroy, 18-912-72-97, Surveyor
 Michael G. Conroy

Know all men by these presents that we, the undersigned, have caused the land in the surveyors certificate to be platted into Lots to be known as "BARNUM ADDITION", Wichita, Sedgwick County, Kansas. The utility easements are hereby granted as indicated for the construction and maintenance of all public utilities. All abutters rights of access to or from MacArthur Road over and across the south line of Lots 1 and 2 are hereby granted to the City of Wichita, Kansas provided, however, that Lot 1 shall have access to MacArthur Road at one location and Lot 2 shall have access to MacArthur Road at one location, all as shall be determined by the City Engineer of the City of Wichita, Kansas.

James D. Barnum
 James D. Barnum

State of Kansas) SS The foregoing instrument acknowledged before me, this 25th day of JANUARY, 1928, by James D. Barnum, a single person.

Judith M. Terhune, Notary Public

My App'l. Exp. 11-7-2001
 JUDITH M. TERHUNE
 Notary Public
 My App'l. Expires 11-7-2001

This plat of "BARNUM ADDITION", Wichita, Sedgwick County, Kansas has been submitted to and approved by the Wichita-Sedgwick County Metropolitan Area Planning Commission, Wichita, Kansas, Dated this 16th day of October, 1927, Wichita-Sedgwick County Metropolitan Area Planning Commission



Richard Lopez, Chairman

Marvin S. Knout, Secretary

This plat approved and all dedications shown hereon accepted by the City Council of the City of Wichita, Kansas, this 3rd day of February, 1928.



Bob Knight, Mayor

Pat Burnett, City Clerk

Entered on transfer record this 27th day of March, 1928.

James Alford, County Clerk

State of Kansas) SS This is to certify that this plat has been filed for record in the office of the Register of Deeds, this 25th day of March, 1928, at 1:00 o'clock P.M. and is duly recorded.

Larry Consover, Register of Deeds

Michael D. Hurtt, Deputy

We, the undersigned, holders of a mortgage on the above described property, do hereby consent to this plat of "BARNUM ADDITION", Wichita, Sedgwick County, Kansas.
 Capital Federal Savings and Loan Association

Connie J. Achille, Post. Cashier

State of Kansas) SS The foregoing instrument acknowledged before me, this 25th day of January, 1928, by Connie J. Achille, Post. Cashier, of Capital Federal Savings and Loan Association, on behalf of the association.

Daniel L. Jones, Notary Public

My App'l. Exp. 3-24-2001
 DANIEL L. JONES
 Notary Public
 My App'l. Expires 3-24-2001



This digital plat record accurately reproduces in all details the original plat filed with the Sedgwick County Register of Deeds. Digitized under the supervision of Register of Deeds Bill Meek by Sedgwick County Geographic Information Systems.
 Bill Meek, Register of Deeds
 Digitized rendition of original signature

AAA MINI STORAGE
 530 EAST MACARTHUR ROAD
 WATER DISTRIBUTION SYSTEM IMPROVEMENTS PLAT
 CITY OF WICHITA, KANSAS
 GARY JANZEN, P.E. - INTERIM CITY ENGINEER
 C.O.W. Proj# XXX-XXXX O.C.A.# XXXXX

POE & ASSOCIATES, INC.
 CONSULTING ENGINEERS
 5940 E. Central, Suite 200 Wichita, KS
 67208-0242
 Phone 316/685-4444 FAX 316/685-4444

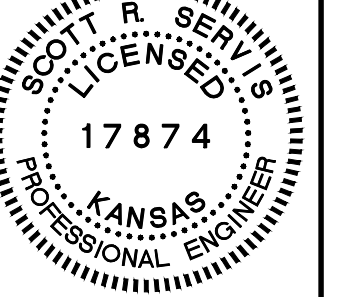
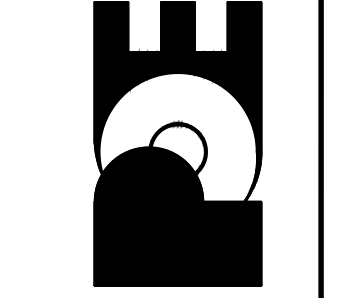

FINAL
 Engineer: S. SERVIS
 Designer: S. SERVIS
 Drawing: P:\1109P\AAA STORAGE\BoseWL.dwg
 Date: 9/25/2012