

Combined Curb & Gutter (6")

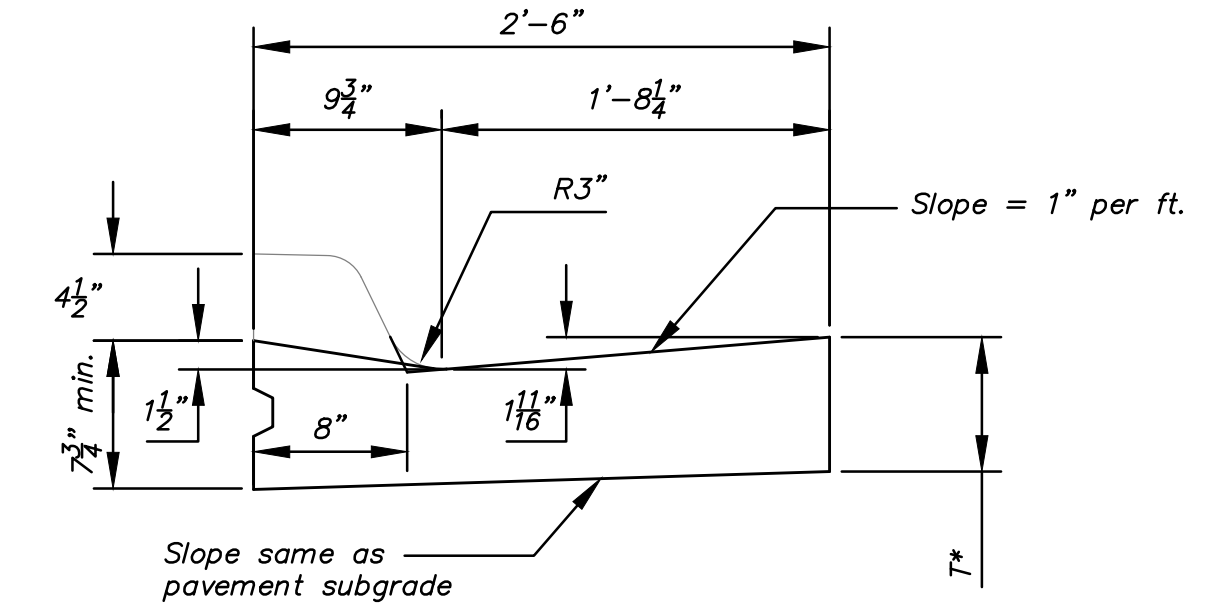

Combined Curb & Gutter (1 1/2")

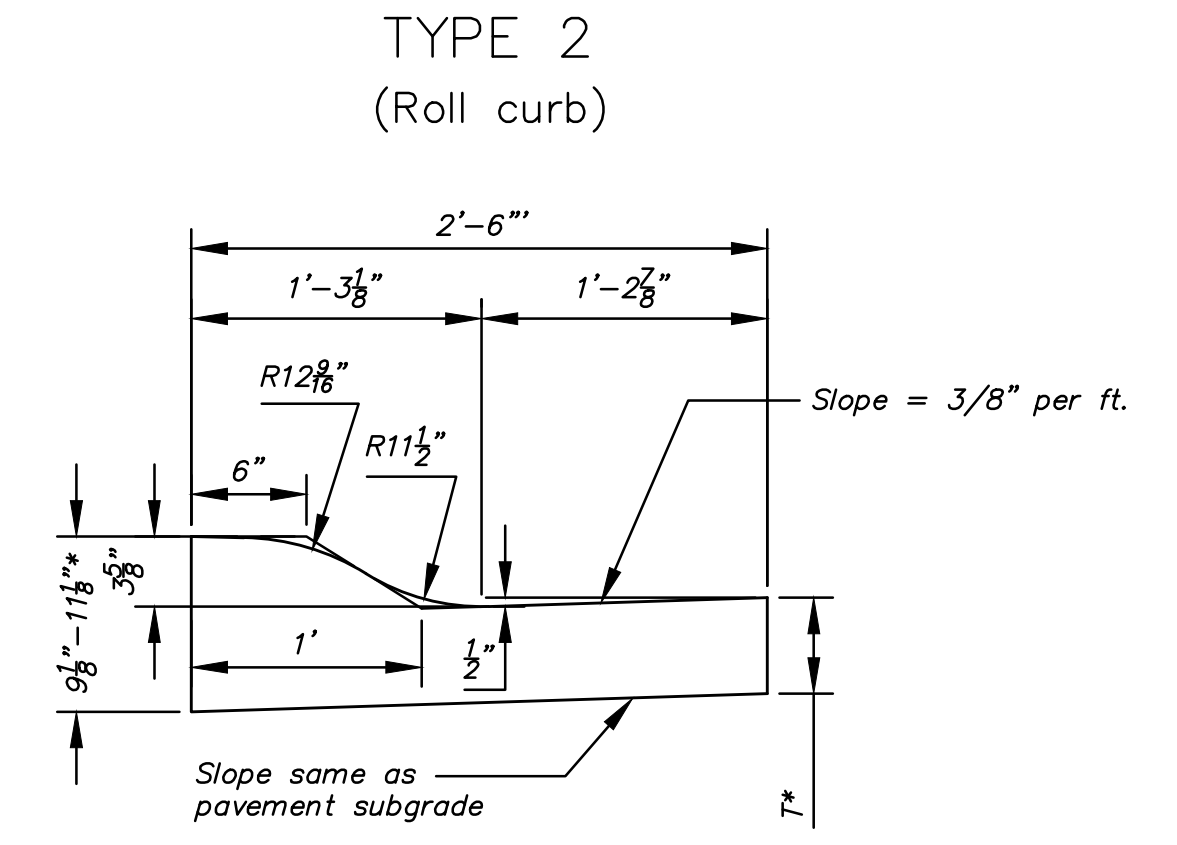

Combined Curb & Gutter (3 5/8")

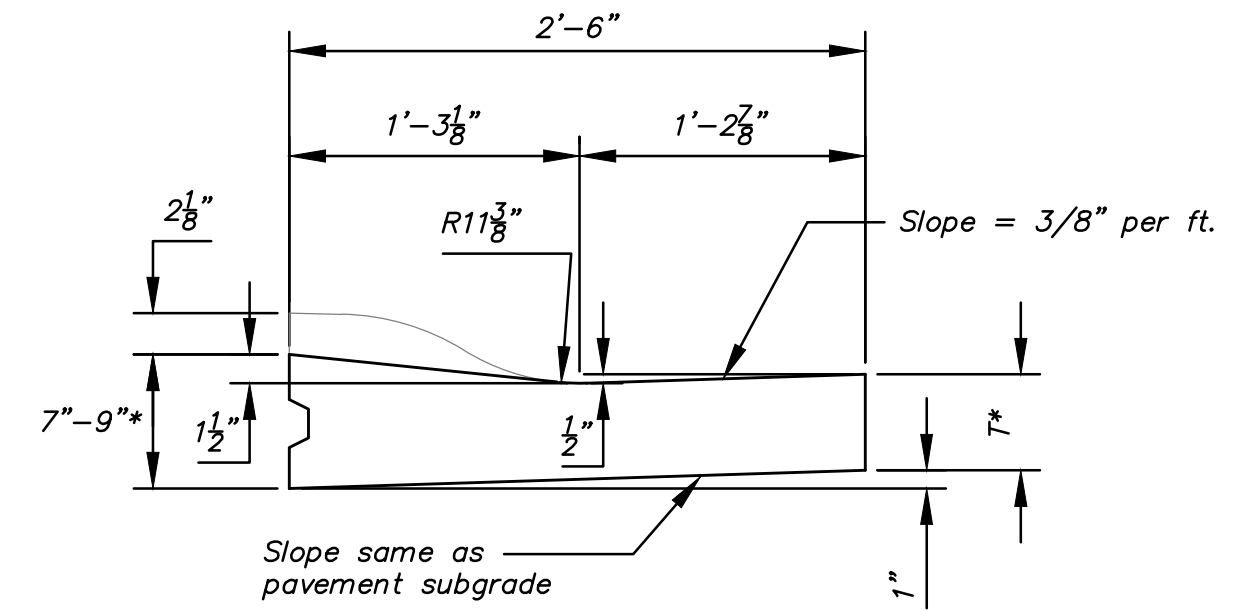

Combined Curb & Gutter (1 1/2")

T\* = Thickness of curb to adjust with pavement thickness

GENERAL NOTES

1. Expansion (isolation) joints shall be constructed a maximum of 300' apart and at all PIs, PCs, cul-de-sac quadrants, and ends of returns.
2. Contraction joints shall be constructed a minimum of 12' apart.
3. Joint sealer shall be required at all joints on arterial and industrial streets and at intersections on residential streets.

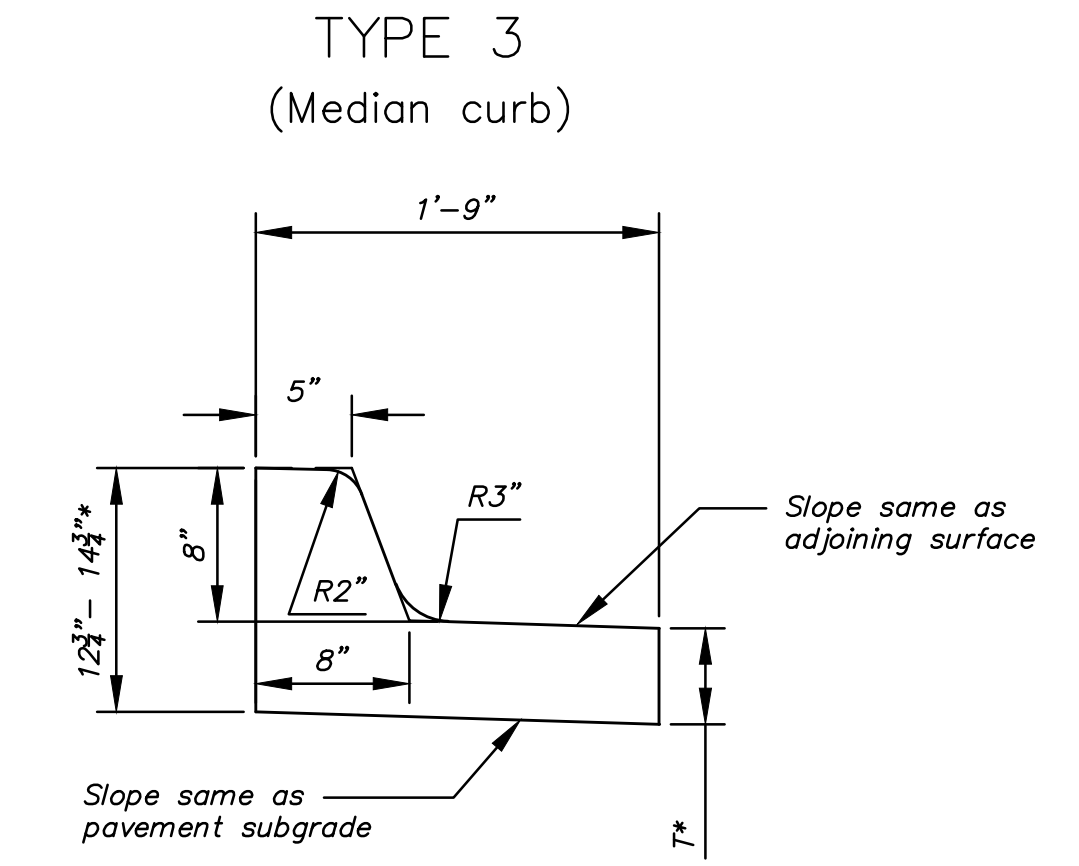

Combined Curb & Gutter (8")

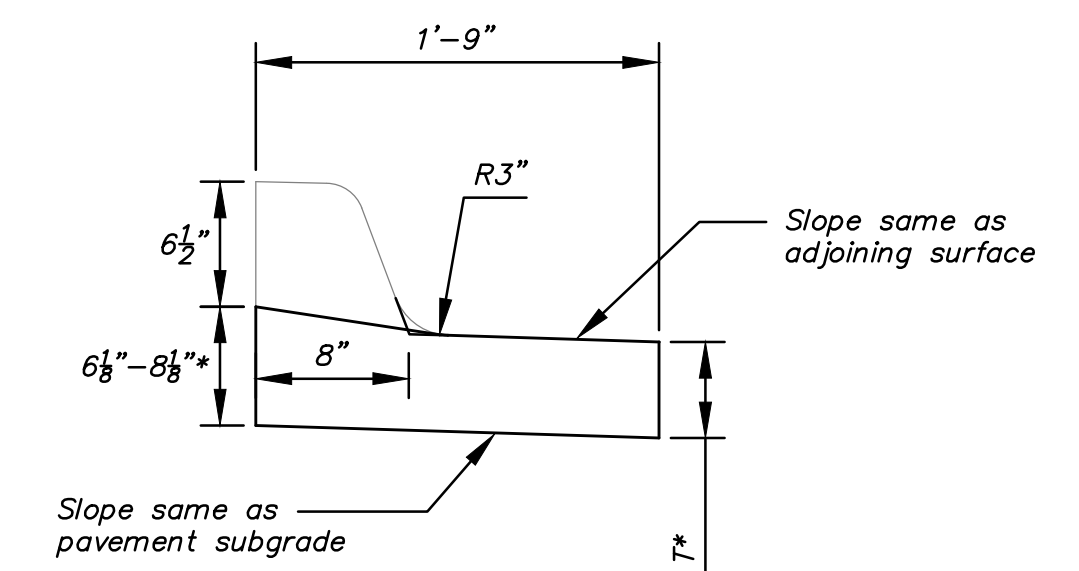

Combined Curb & Gutter (1 1/2")

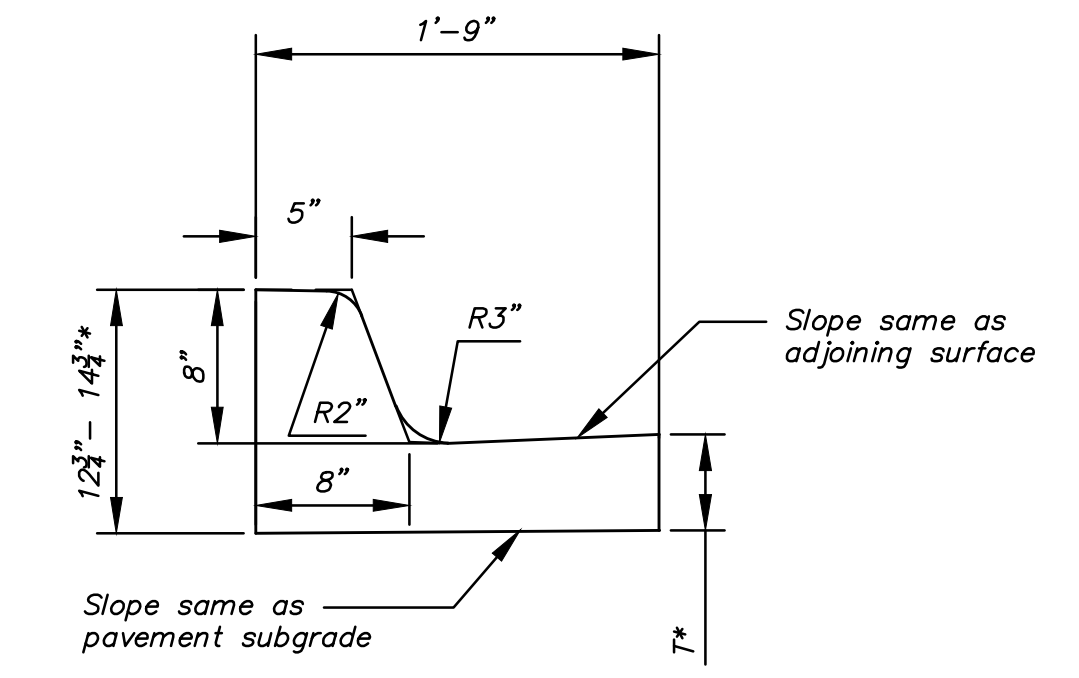

Combined Curb & Gutter (8") High Edge

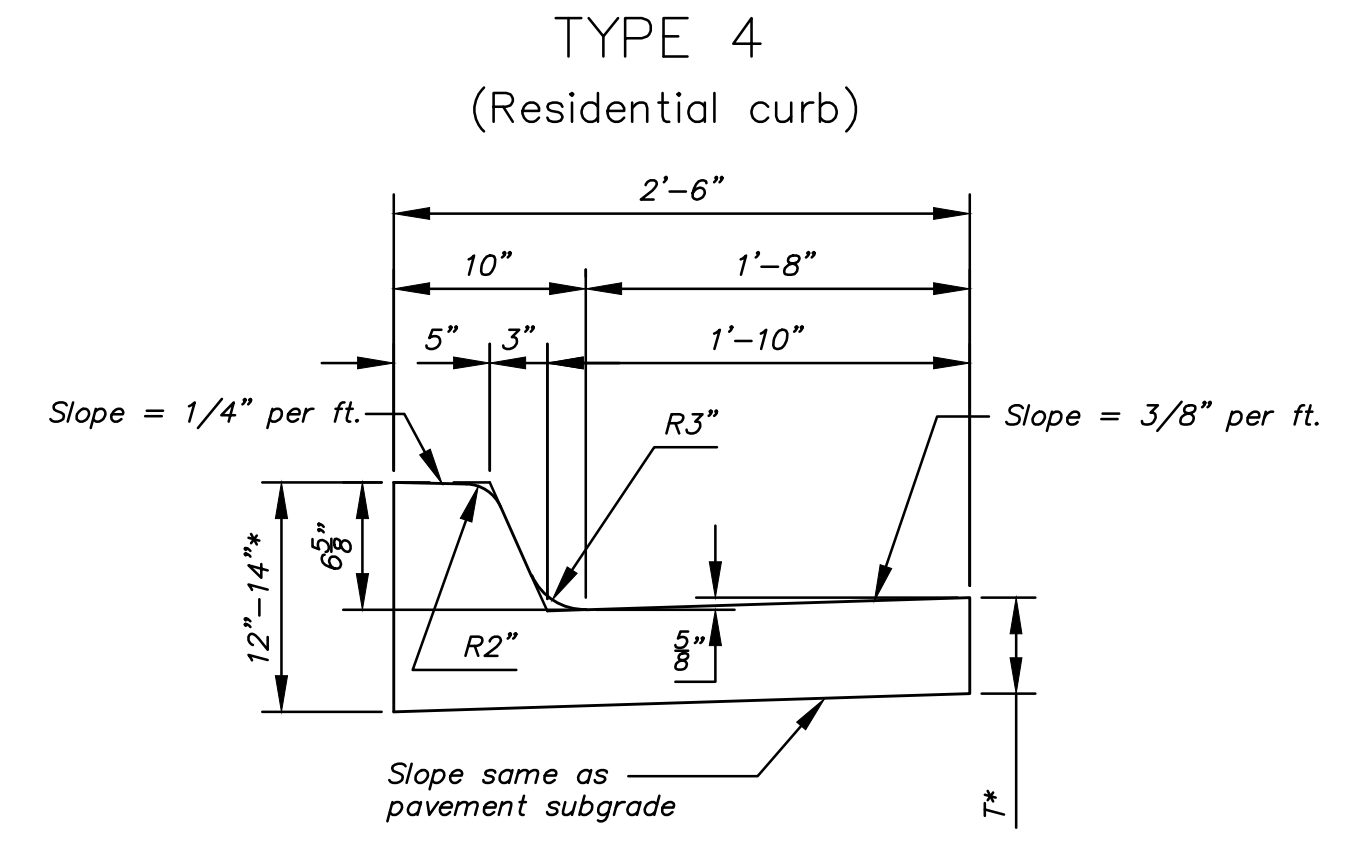

Combined Curb & Gutter (6 5/8")

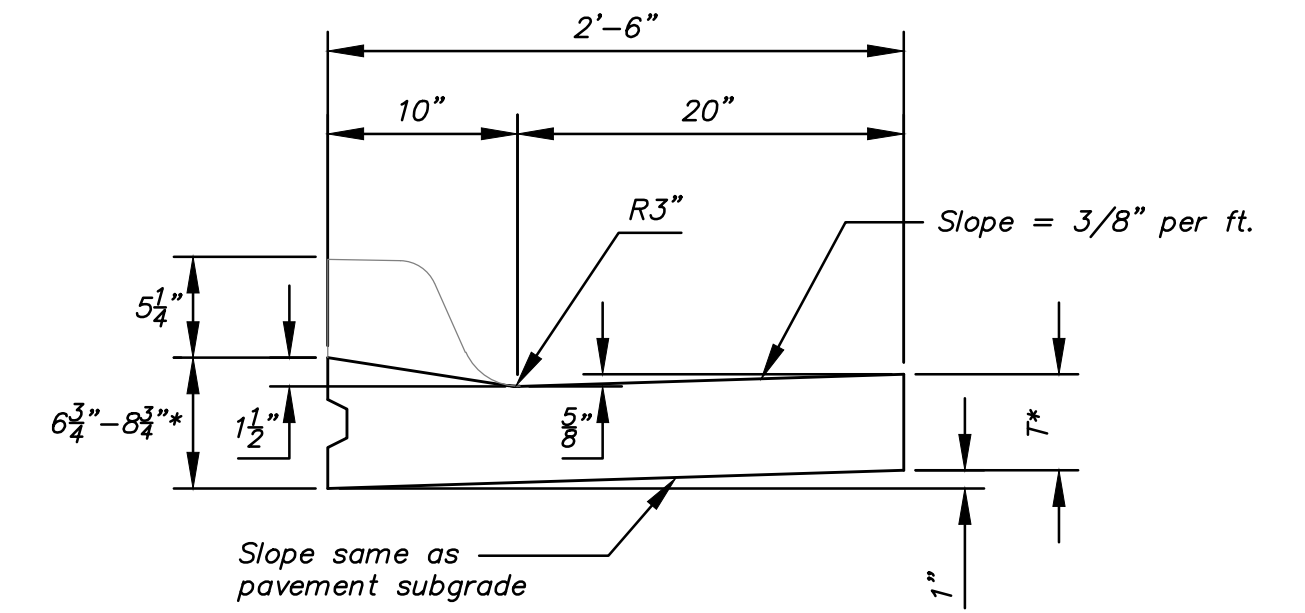

Combined Curb & Gutter (1 1/2")

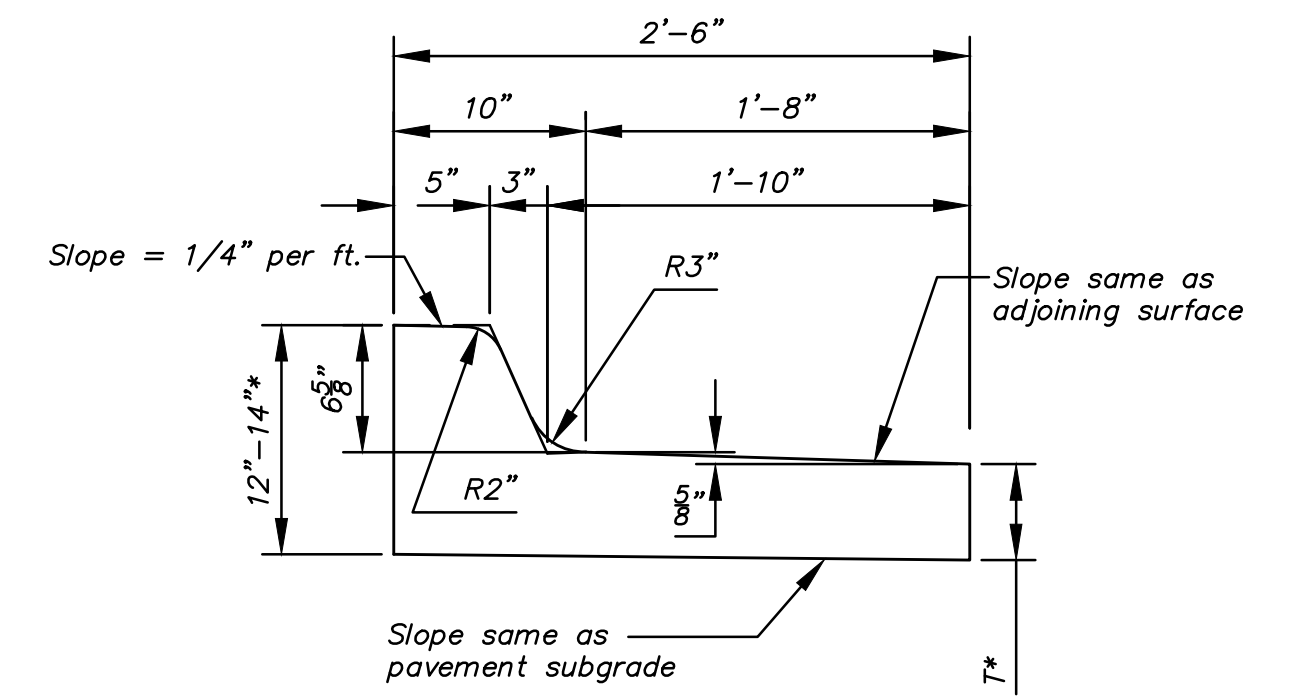

Combined Curb & Gutter (6 5/8") Low Edge

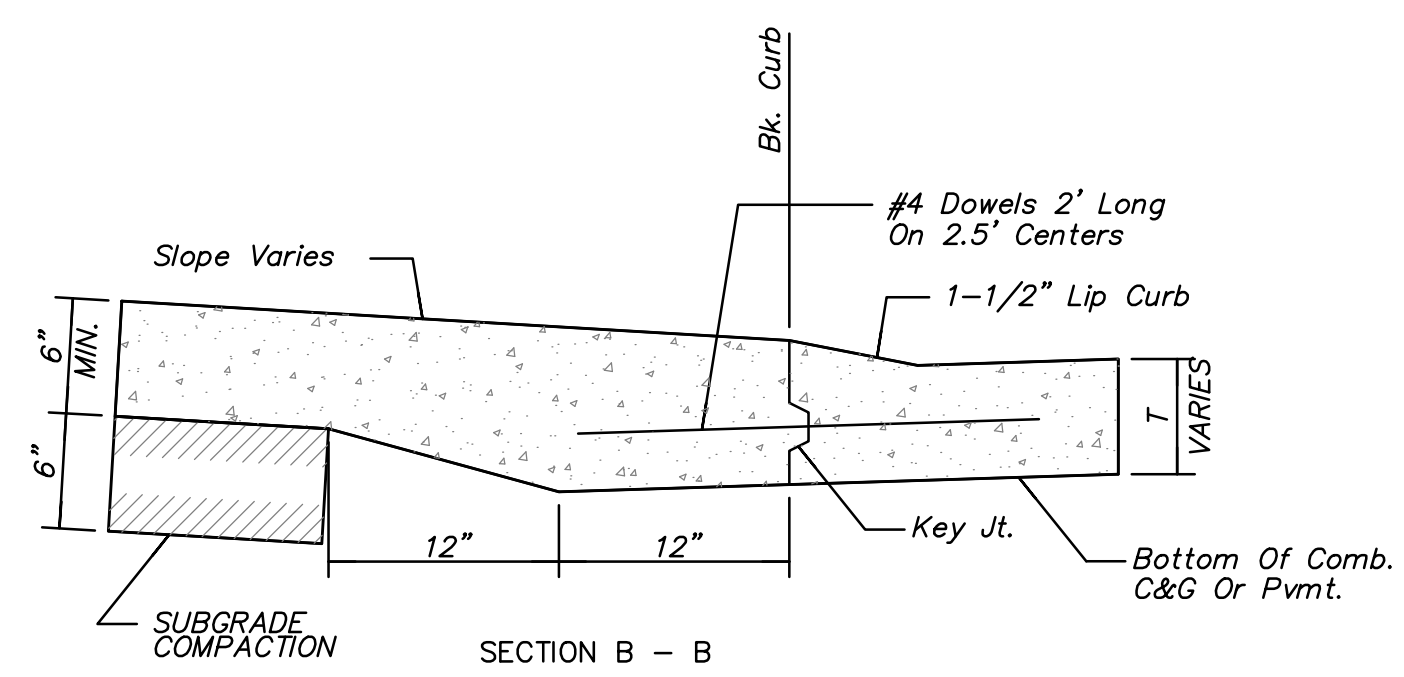

SECTION B - B  
BACK OF CURB DETAIL

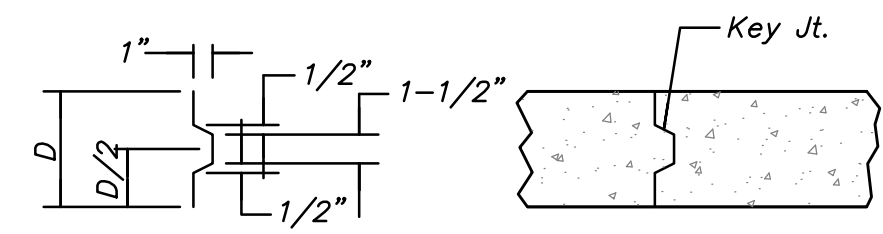

ALT. LONGITUDINAL CONSTRUCTION JOINT

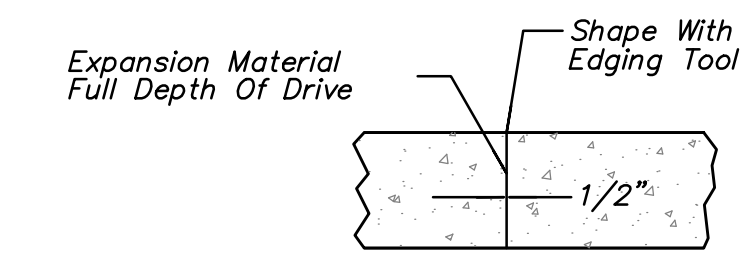

EXPANSION JOINT (E.J.)

 <b>CITY OF WICHITA</b> PUBLIC WORKS & UTILITIES ENGINEERING DIVISION	<b>CURB &amp; GUTTER DETAILS</b>		
	CITY ENGINEER <b>GARY JANZEN, P.E.</b>		
	PROJECT NUMBER 472-85106	OCA NUMBER 766340	DATE
	CITY ENGINEER'S OFFICE CITY HALL - SEVENTH FLOOR 455 NORTH MAIN STREET WICHITA, KANSAS 67202-1620 (316) 268-4501		<b>3 of 28</b>