

STATE	PROJECT NO.	YEAR	SHEET NO.	TOTAL SHEETS
KANSAS	87 N-0612-01	2015	13	84



CONSTRUCTION PLANS FOR  
**21ST STREET BRIDGE AT DERBY REFINERY**  
 WICHITA, KANSAS

©2013  
 MKEC Engineering  
 All Rights Reserved  
 www.mkec.com  
 These drawings and their contents, including, but not limited to, all concepts, designs, & ideas are the exclusive property of MKEC Engineering (MKEC), and may not be used or reproduced in any way without the express consent of MKEC.

**MISCELLANEOUS PAVING DETAILS**

PROJECT NO.	472-85120	
DATE	JULY 2015	
SCALE	NO SCALE	
DESIGNED	DRAWN	CHECKED
JRA	WNJ	JRA
NO.	REVISION	DATE

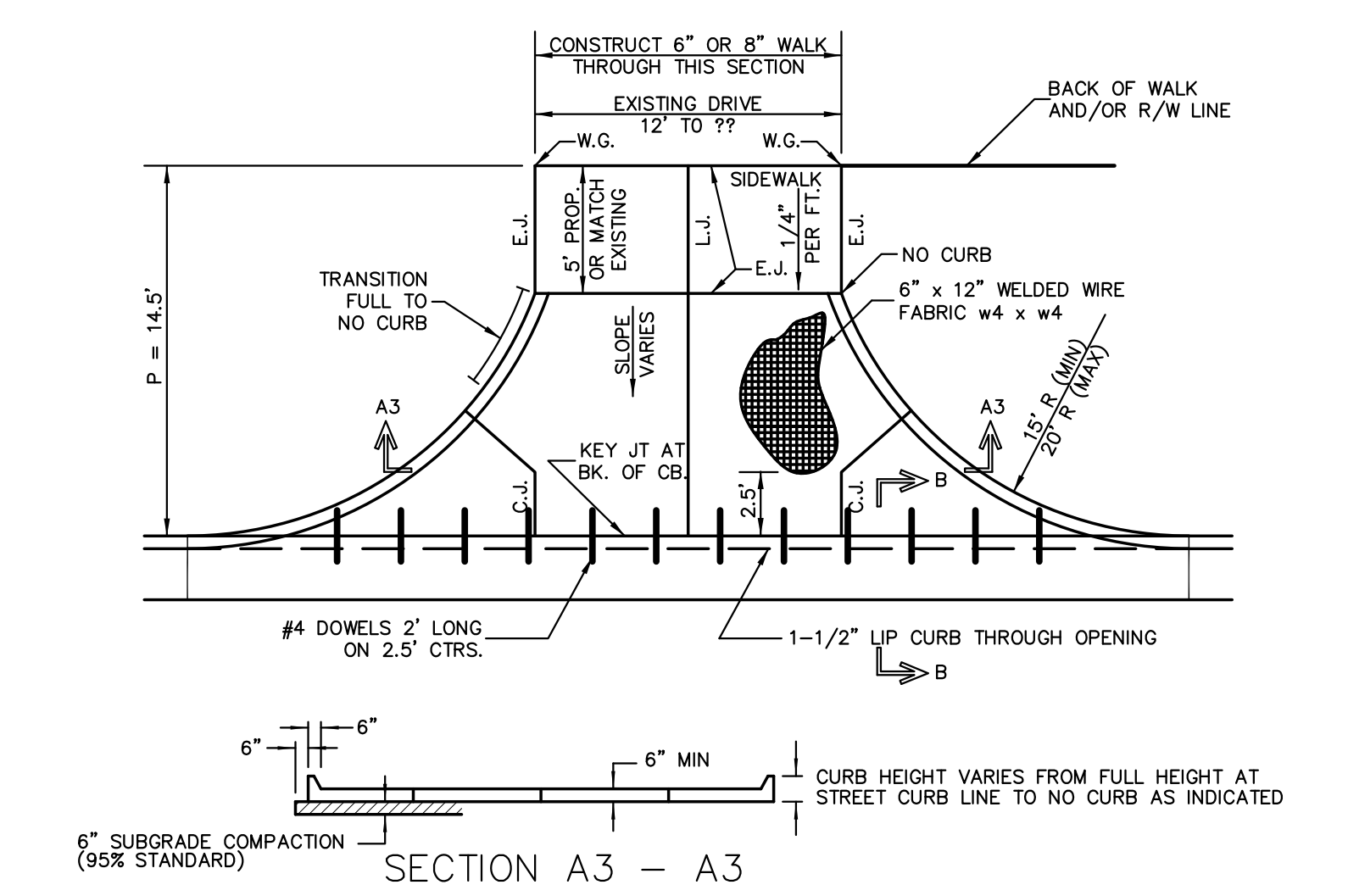

PARKING WIDTH "P"	14.5'	20'	25'	30'	35'	40'	45'	50'
ABSOLUTE MAX. DIST. OF PT. "WC" ABOVE OR BELOW TOP OF FULL CURB	0.72	1.27	1.77	2.27	2.77	3.27	3.77	4.27
OPTIMUM MAX. DIST. OF PT. "WC" ABOVE OR BELOW TOP OF FULL CURB	0.70	1.04	1.30	1.56	1.82	2.08	2.35	2.60
OPTIMUM MIN. DIST. OF PT. "WC" ABOVE OR BELOW TOP OF FULL CURB	0.30	0.42	0.52	0.62	0.72	0.82	0.92	1.02
ABSOLUTE MIN. DIST. OF PT. "WC" ABOVE OR BELOW TOP OF FULL CURB	0.00	0.00	0.15	0.25	0.35	0.45	0.55	0.65

FULL RADIUS DRIVES (P = 14.5' & GREATER)

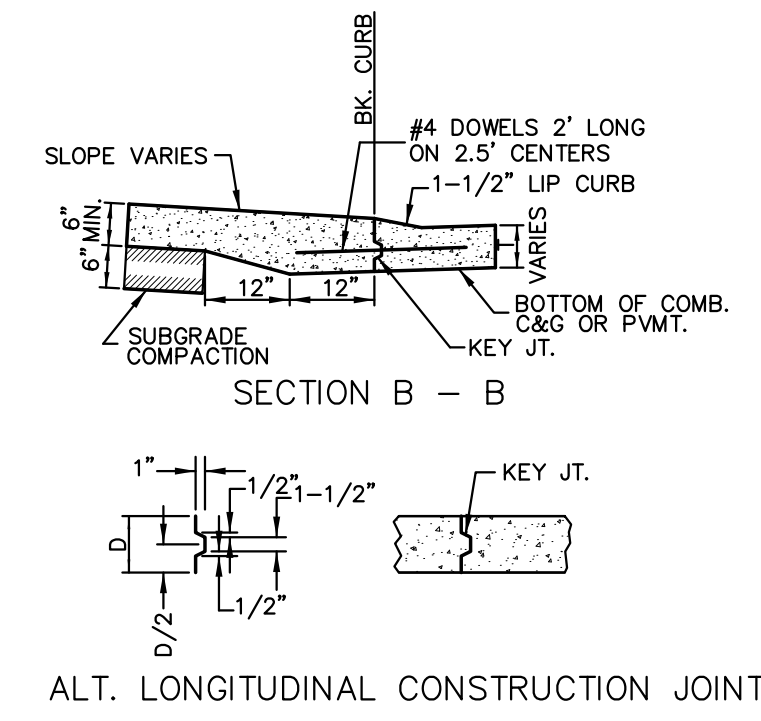

BACK OF CURB DETAIL

**GENERAL NOTES**

- DRIVEWAY CONSTRUCTION DETAILED ON THIS SHEET IS FOR USE WITH FULL HEIGHT STREET CURBS AND IN AREAS WITHOUT FULL WALK CONSTRUCTION IN THE PARKING. SEE OTHER DETAIL SHEETS FOR DRIVEWAY CONSTRUCTION WITH ROLL CURB AND/OR FULL WALK.
- ONE LONGITUDINAL JOINT SHALL BE CONSTRUCTED ALONG THE CENTERLINE OF DRIVES HAVING A "W" DIMENSION OF 24' OR LESS. TWO LONGITUDINAL JOINTS SHALL BE CONSTRUCTED WITH EQUAL SPACINGS NOT TO EXCEED 10' FOR DRIVES WITH A "W" DIMENSION GREATER THAN 24'.
- DRIVEWAY WIDTH DENOTED AS "W" ON THE DETAIL DRAWINGS SHALL BE A MINIMUM OF 12' AND A MAXIMUM OF 30'. THE MAXIMUM OPENING FOR RADIUS TYPE DRIVES WITH CURBS THROUGH THE RADIUS SHALL NOT EXCEED 52' AT THE STREET CURB LINE.
- CONTRACTION JOINT SPACING IN THE DRIVEWAY WALK SECTION SHALL BE A MINIMUM OF 3' AND A MAXIMUM OF 6' AND ARE TO BE EQUALLY SPACED WITHIN THIS RANGE. WALK SECTION SHALL BE CONSTRUCTED TO THE SAME THICKNESS AS THE DRIVEWAY.
- ADDITIONAL THICKNESS OF DRIVE AS INDICATED IN THE DRAWINGS WILL NOT BE PAID FOR DIRECTLY AND THIS COST SHALL BE INCLUDED IN THE UNIT PRICE BID FOR THE DRIVEWAY CONSTRUCTION.
- ONE HALF INCH EXPANSION JOINTS SHALL BE INSTALLED WHEREVER DRIVE CONSTRUCTION ABUTS SIDEWALK. ONE HALF INCH EXPANSION JOINTS SHALL ALSO BE INSTALLED ALONG THE PROPERTY LINE AND/OR BACK OF WALK LINE WHEN DRIVE CONSTRUCTION ALONG THIS LINE ABUTS CONCRETE PARKING LOTS OR CONCRETE DRIVE EXTENSION.
- ALL DRIVEWAYS SHALL BE A MINIMUM OF 6" IN THICKNESS AND SHALL BE WITHOUT REINFORCEMENT. DRIVEWAYS MAY BE CONSTRUCTED THICKER THAN 6" AND THEY MAY BE REINFORCED WITH 6"x12" W4-W4 WELDED WIRE FABRIC WHEN PROPERLY AUTHORIZED BY THE PROPERTY OWNER WITH THE ENGINEER'S CONCURRENCE.
- ALL DRIVEWAYS TO COMMERCIAL PROPERTY SHALL BE A MINIMUM OF 8" IN THICKNESS AND SHALL HAVE REINFORCEMENT WITH 6"x12", W4xW4.
- OPTIMUM DRIVEWAY ELEVATIONS SHOWN IN THE TABLES ARE TO BE USED WHEREVER POSSIBLE. ABSOLUTE MAXIMUM AND MINIMUM ELEVATIONS ARE TO BE USED ONLY WHEN THESE VALUES WILL PERMIT NEW CONSTRUCTION TO MATCH EXISTING DRIVES OR PARKING LOTS. VALUES SHOWN IN THE TABLES ARE BASED ON A FULL CURB HEIGHT ELEVATION OF 0.55' ABOVE THE GUTTER FLOW LINE AND MUST BE ADJUSTED ACCORDINGLY FOR OTHER CURB HEIGHTS. VALUES SHOWN IN THE TABLES WITH MINUS SIGNS INDICATE ELEVATIONS BELOW TOP OF FULL HEIGHT CURB.

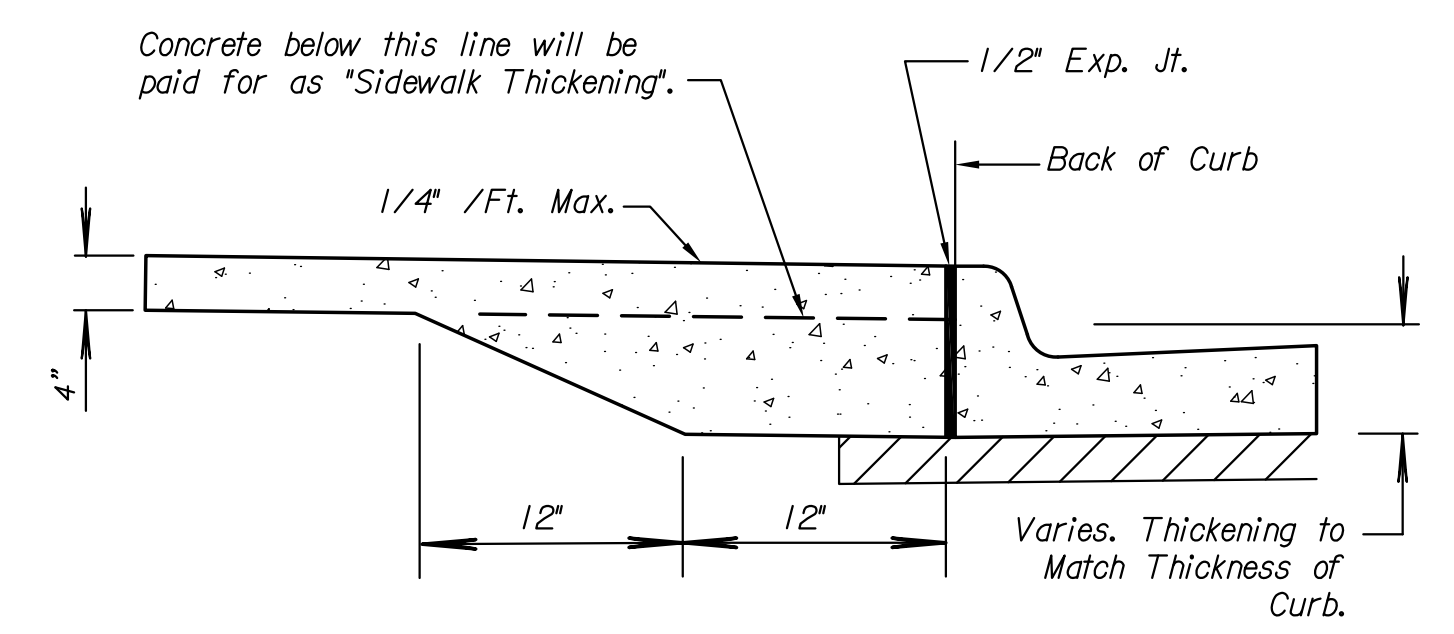

**SIDEWALK THICKENING**

Note: All Sidewalk at Back of Curb Shall Conform to this Detail

2" Depth Knife Cut Shape w/ "Vee" Tool

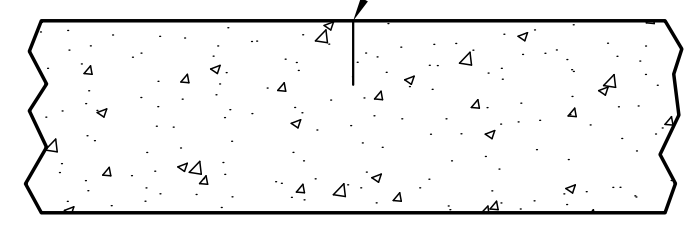

No Sawn Joints Will Be Allowed

**CONTRACTION JOINT (C.J.)**

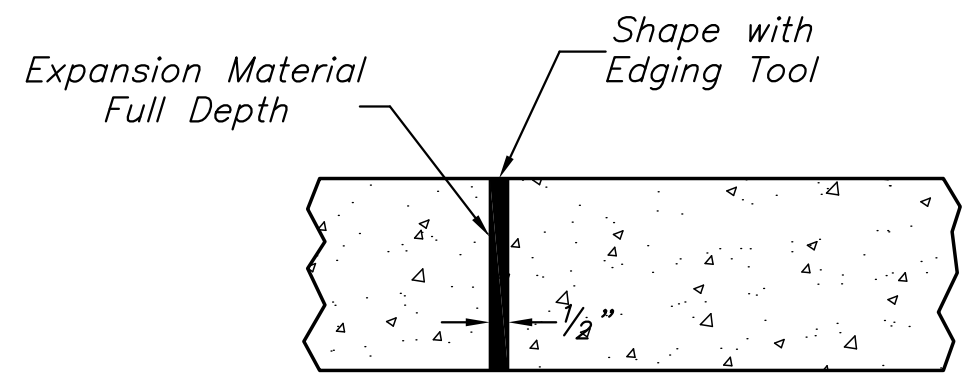

**EXPANSION JOINT (E.J.)**

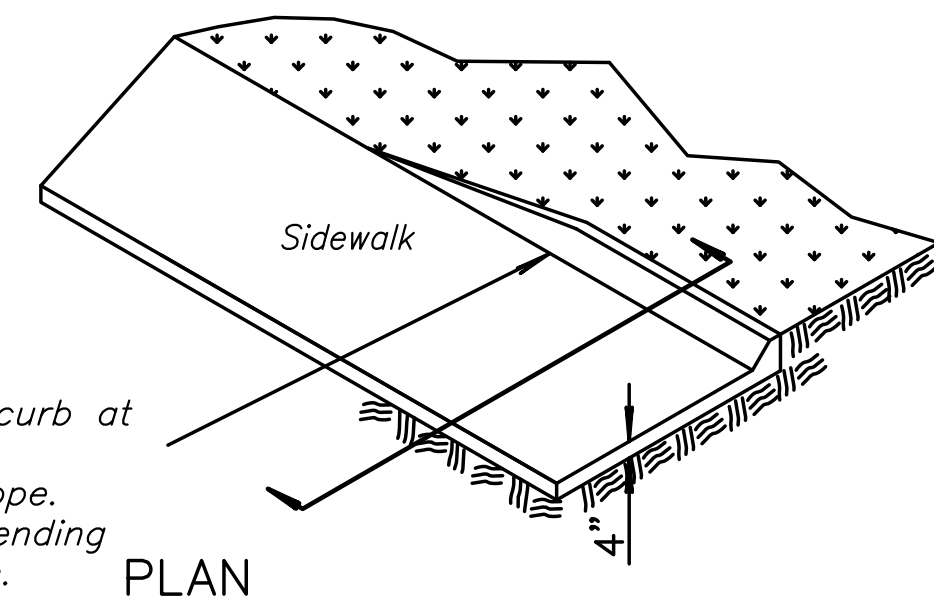

**PROTECTION CURB**

- Note:
- Protection Curb shall be constructed at locations as directed by Engineer.
  - Protection Curb shall be constructed monolithically with sidewalk.
  - Protection Curb height shall be 6" or 8" as directed by Engineer.

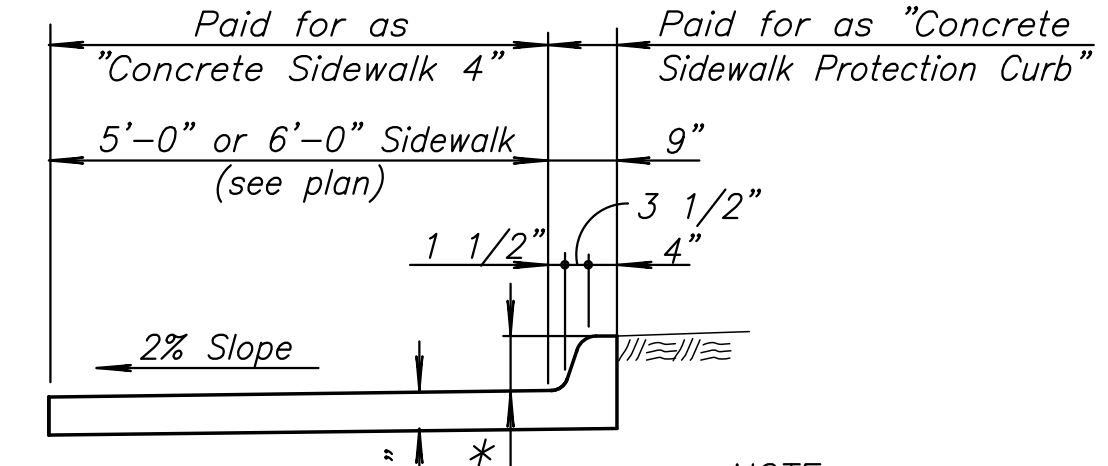

**SECTION**

\* Transition at ends as shown on the plans.

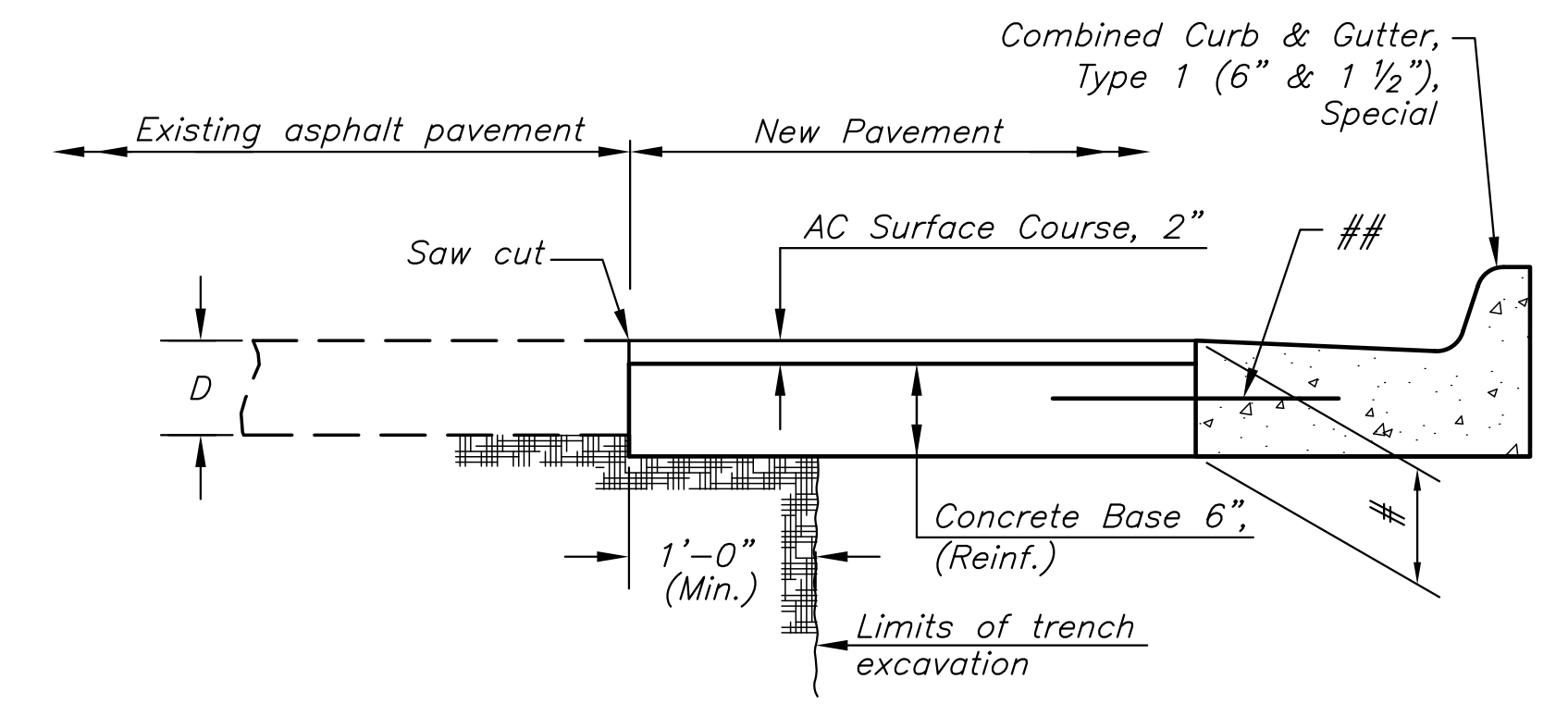

**PAVEMENT PATCH DETAIL**

The bid item "Pavement &/or Curb Removed and Replaced" shall include removal of existing pavement and/or curb and the construction of pavement patches which may include curb as shown.

# Curb thickness at high edge to be 8"  
## #5 x 36" bar @ 30" ctrs.

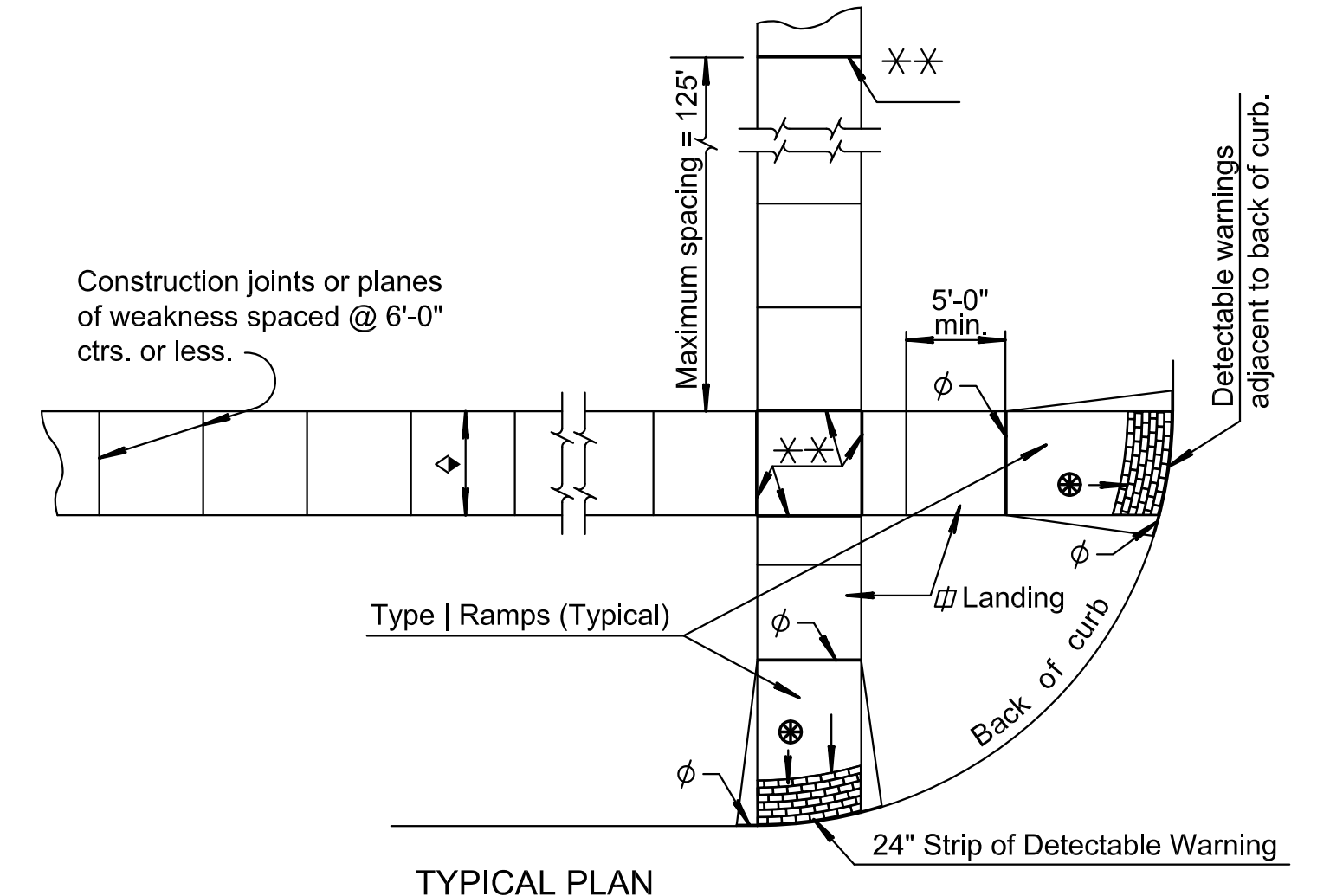

TYPICAL PLAN

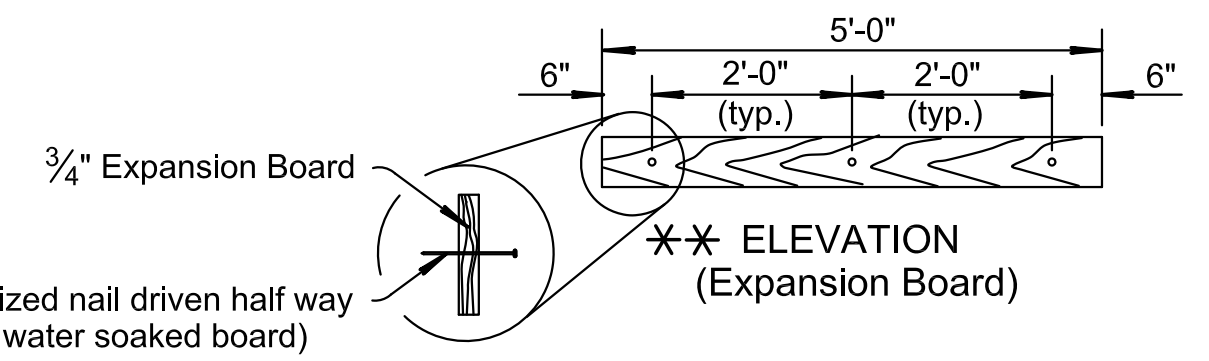

**ELEVATION (Expansion Board)**

For other than 5'-0" (width) use 6" from the end and balanced (3'-0" max.) nail spacing.

- ∅ Expansion Joint (3/4" board) placed at either back of curb line or at sidewalk back of curb line or at sidewalk line.
- ✱ Expansion joint (3/4" board) located as shown.
- ◇ Variable width (5'-0" min.). Entrance walk to be same width as approach walk. Use sidewalk width of 4'-0" where existing conditions prohibit use of 5'-0".
- ☆ New construction ramp slopes are 12:1 or flatter. Desirable ramp slopes for existing sites are 12:1 or flatter. Where space limitations prohibit construction of a 12:1 slope on existing sites, use the following slopes:  
8:1 or flatter for a maximum rise of 3 inches  
10:1 or flatter for a maximum rise of 6 inches
- ∏ Use a landing slope of 48:1 or flatter. Landings are the same width as ramp and a minimum 5'-0" in length.
- ∏ Use a counter slope of 20:1 or flatter at the base of sidewalk ramps. See curb and gutter detail sheet.
- ⊗ Detectable warning installation is typical and required on Sidewalk Ramps Type 1, Type 2, Type 3, median ramp crossings and other locations as shown in the plans. See ramp detail sheet.

**TYPICAL SIDEWALK PLAN AND DETAILS**