

DETAIL #1 - WEST MEDIAN CUT-THROUGH
(1" = 5')

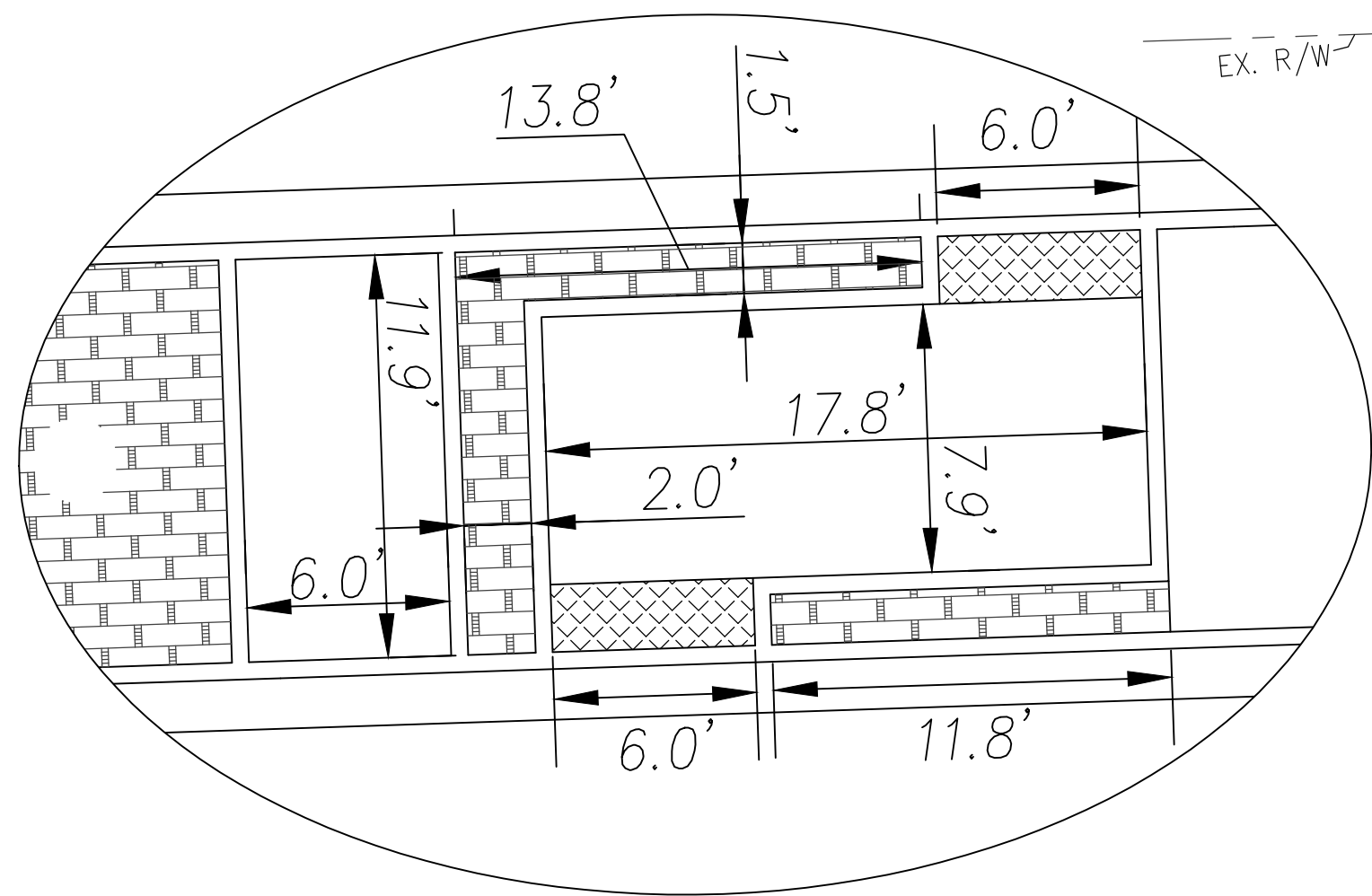

DETAIL #2 - EAST MEDIAN CUT-THROUGH
(1" = 5')

CENTRAL AVE. AND REDBARN LANE

Geometric Notes

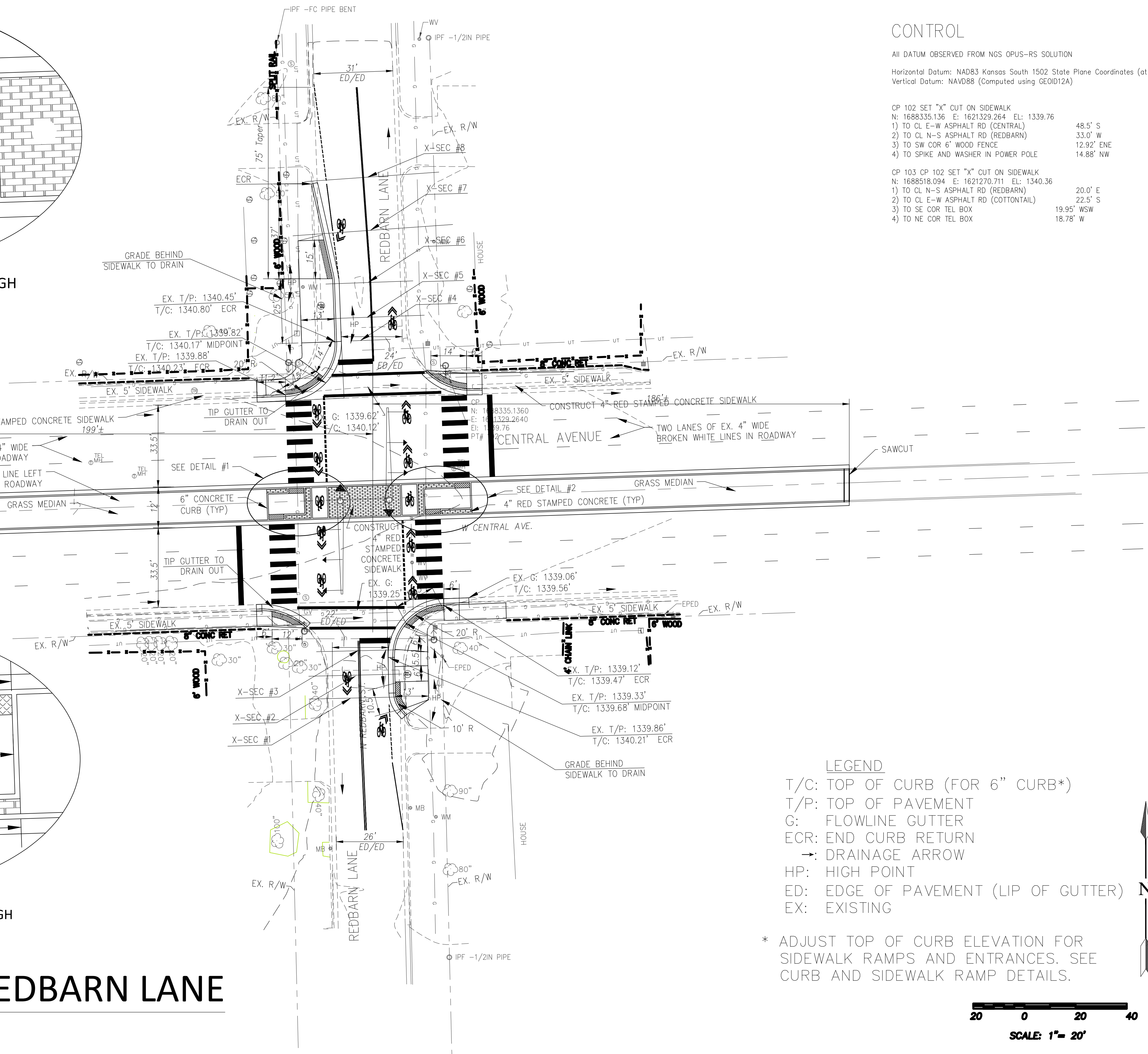

CONTROL

All DATUM OBSERVED FROM NGS OPUS-RS SOLUTION
Horizontal Datum: NAD83 Kansas South 1502 State Plane Coordinates (at ground)
Vertical Datum: NAVD88 (Computed using GEOID12A)

CP 102 SET "X" CUT ON SIDEWALK
N: 1688335.136 E: 1621329.264 EL: 1339.76
1) TO CL E-W ASPHALT RD (CENTRAL) 48.5' S
2) TO CL N-S ASPHALT RD (REDBARN) 33.0' W
3) TO SW COR 6' WOOD FENCE 12.92' NE
4) TO SPIKE AND WASHER IN POWER POLE 14.88' NW

CP 103 CP 102 SET "X" CUT ON SIDEWALK
N: 1688518.094 E: 1621270.711 EL: 1340.36
1) TO CL N-S ASPHALT RD (REDBARN) 20.0' E
2) TO CL E-W ASPHALT RD (COTTONTAIL) 22.5' S
3) TO SE COR TEL BOX 19.95' WSW
4) TO NE COR TEL BOX 18.78' W

LEGEND

- T/C: TOP OF CURB (FOR 6" CURB*)
- T/P: TOP OF PAVEMENT
- G: FLOWLINE GUTTER
- ECR: END CURB RETURN
- : DRAINAGE ARROW
- HP: HIGH POINT
- ED: EDGE OF PAVEMENT (LIP OF GUTTER)
- EX: EXISTING

* ADJUST TOP OF CURB ELEVATION FOR SIDEWALK RAMPS AND ENTRANCES. SEE CURB AND SIDEWALK RAMP DETAILS.



SCALE: 1" = 20'

SEAL:

GRADING AND
LAYOUT PLAN

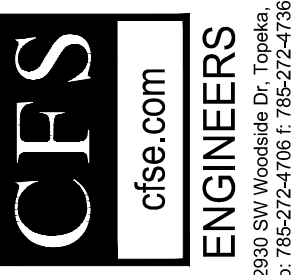

CITY OF WICHITA, KANSAS
WOODCHUCK
BICYCLE BOULEVARD

DESIGNED BY: PW DRAWN BY: JH CHECKED BY: PW

REVISED

PROJECT NUMBER
87 TE-0617-01

FINAL
PLANS

SHEET NUMBER:
PS412