

TYPE 1  
(Arterial curb)

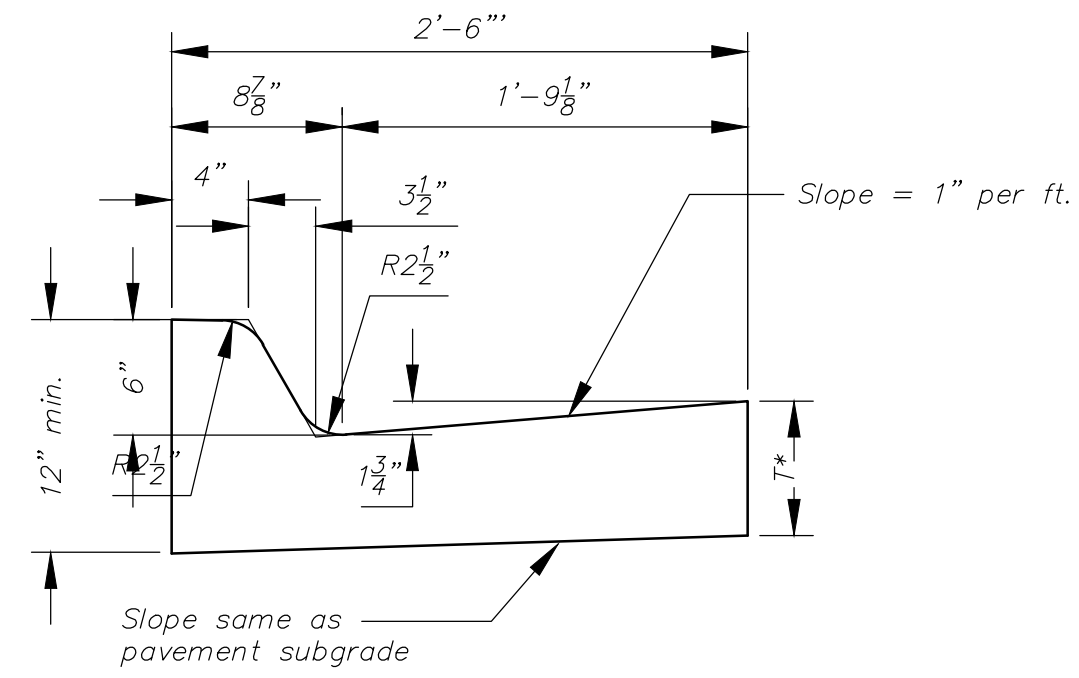

Combined Curb & Gutter (6")

TYPE 2  
(Roll curb)

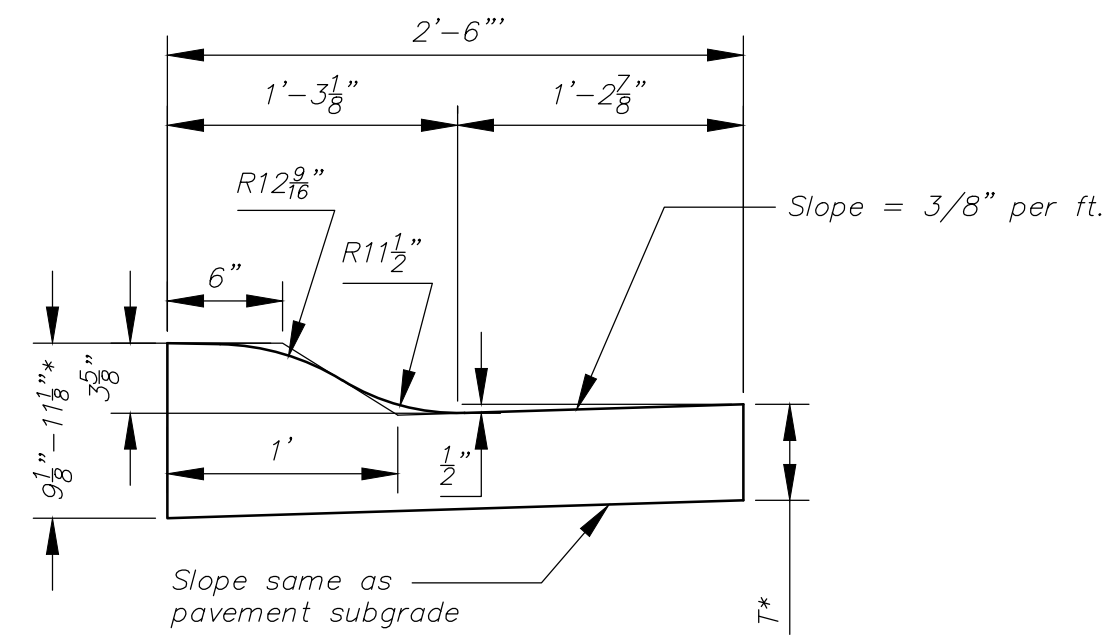

Combined Curb & Gutter (3 5/8")

TYPE 3  
(Median curb)

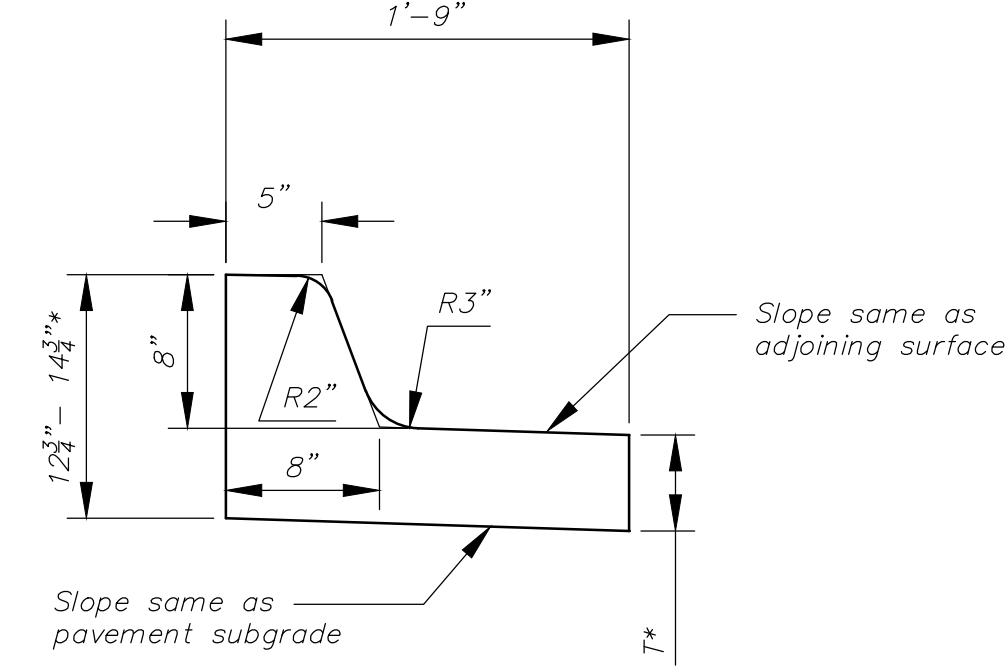

Combined Curb & Gutter (8")

TYPE 4  
(Residential curb)

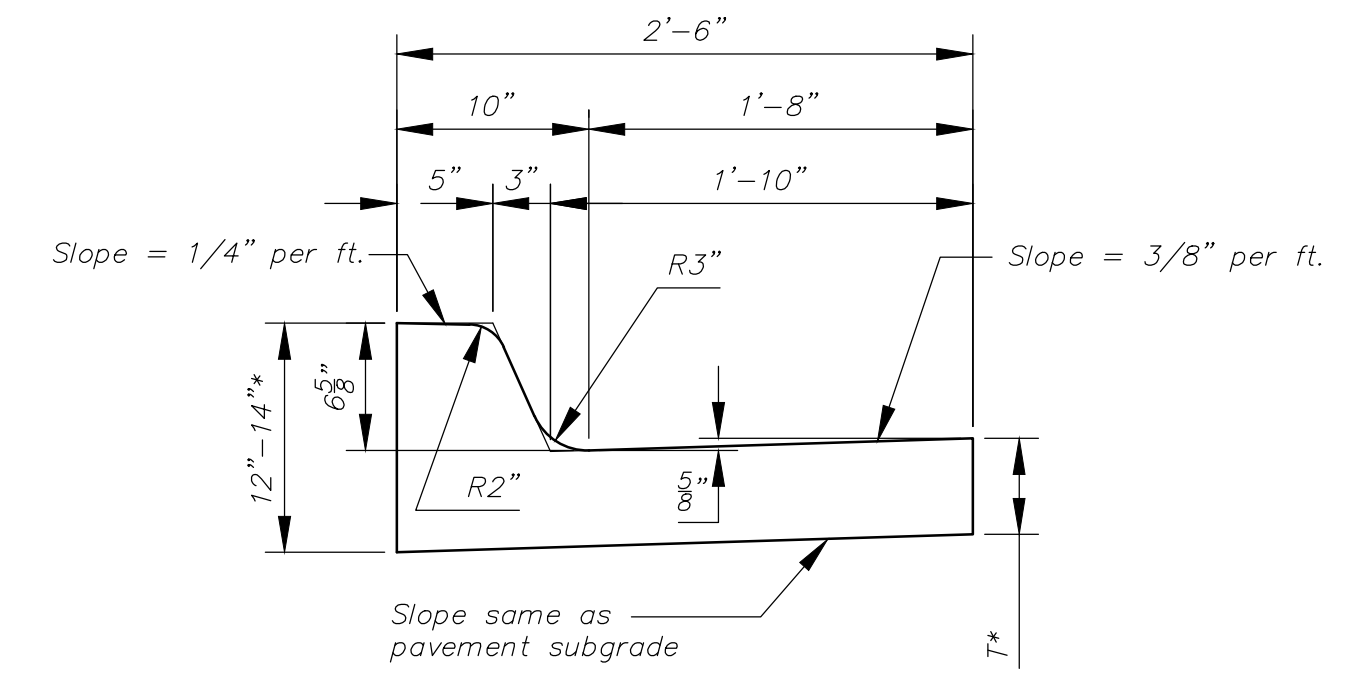

Combined Curb & Gutter (6 5/8")

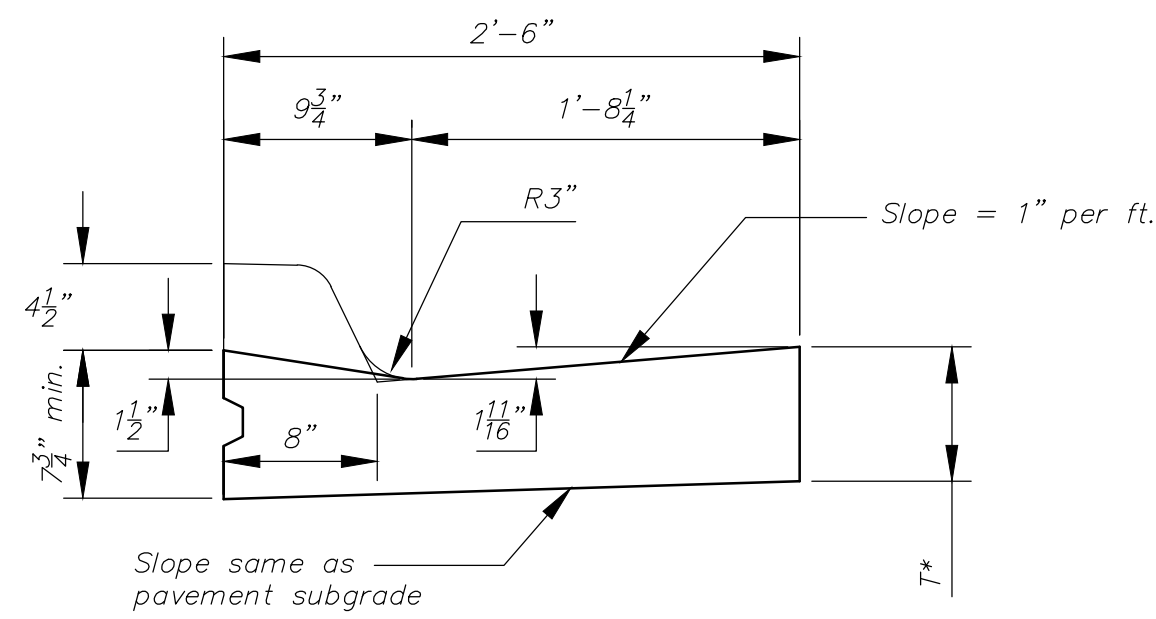

Combined Curb & Gutter (1 1/2")

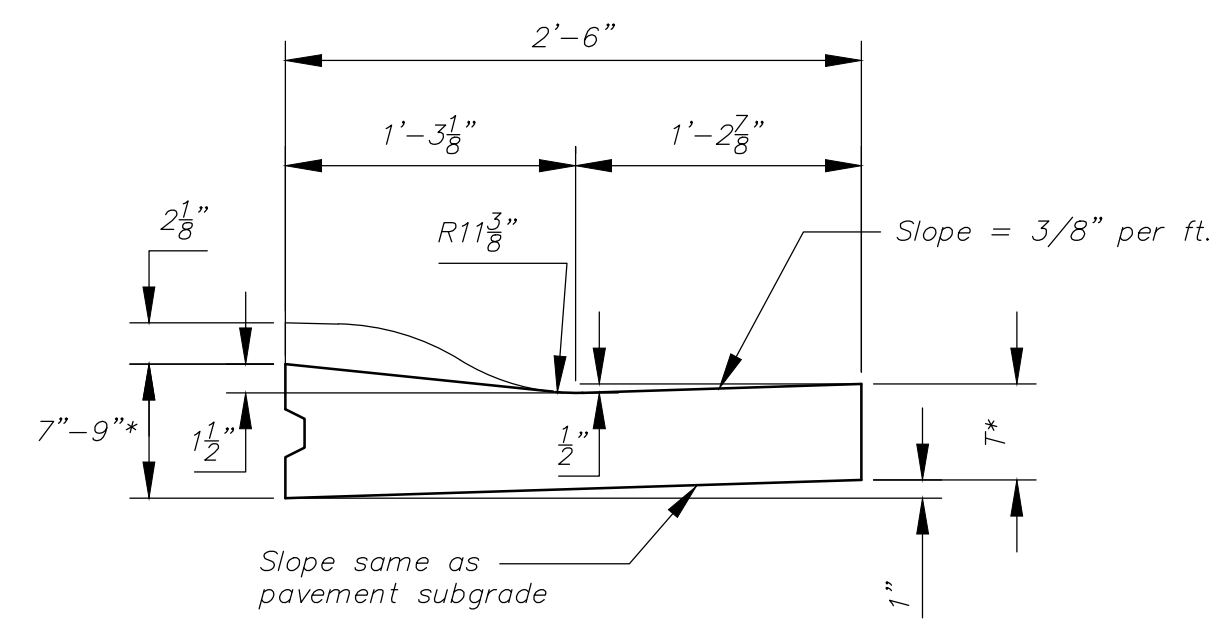

Combined Curb & Gutter (1 1/2")

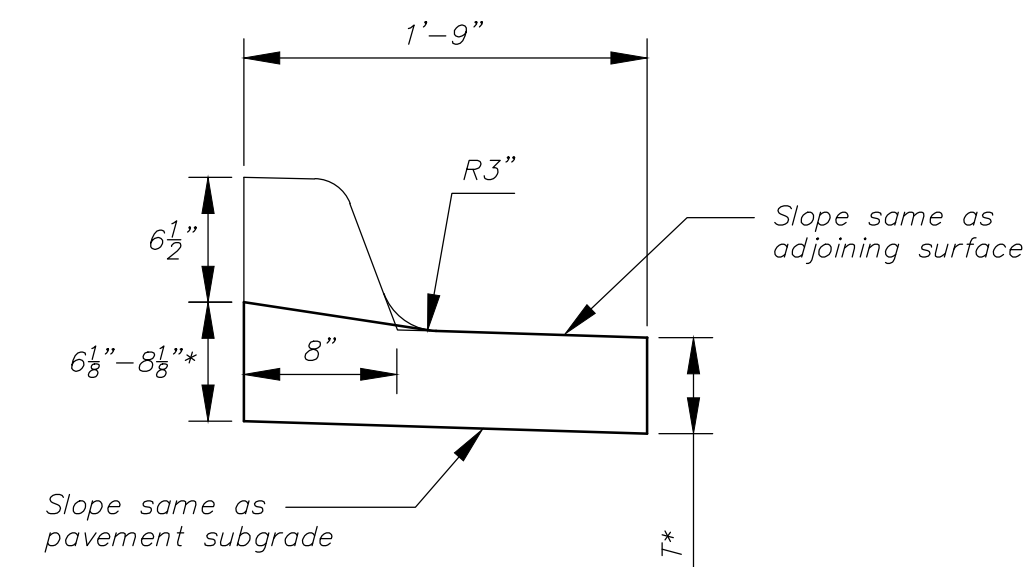

Combined Curb & Gutter (1 1/2")

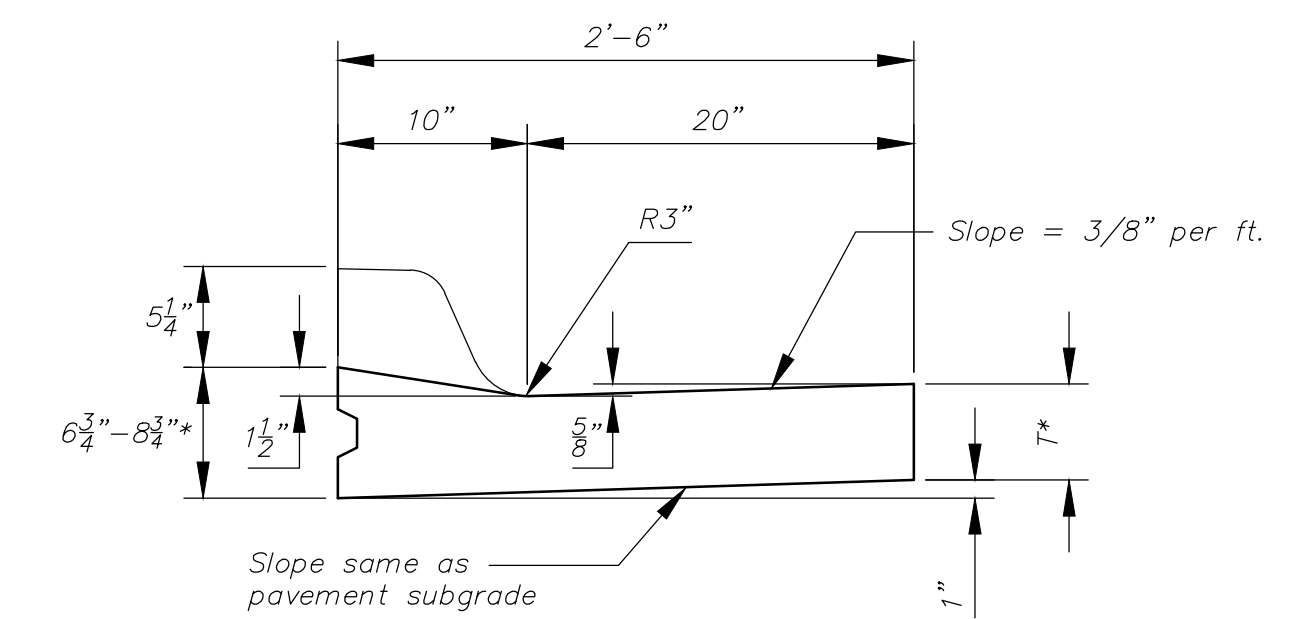

Combined Curb & Gutter (1 1/2")

T\* = Thickness of curb to adjust with pavement thickness

GENERAL NOTES

- Expansion (isolation) joints shall be constructed a maximum of 300' apart and at all PIs, PCs, cul-de-sac quadrants, and ends of returns.
- Contraction joints shall be constructed a minimum of 12' apart.
- Joint sealer shall be required at all joints on arterial and industrial streets and at intersections on residential streets.

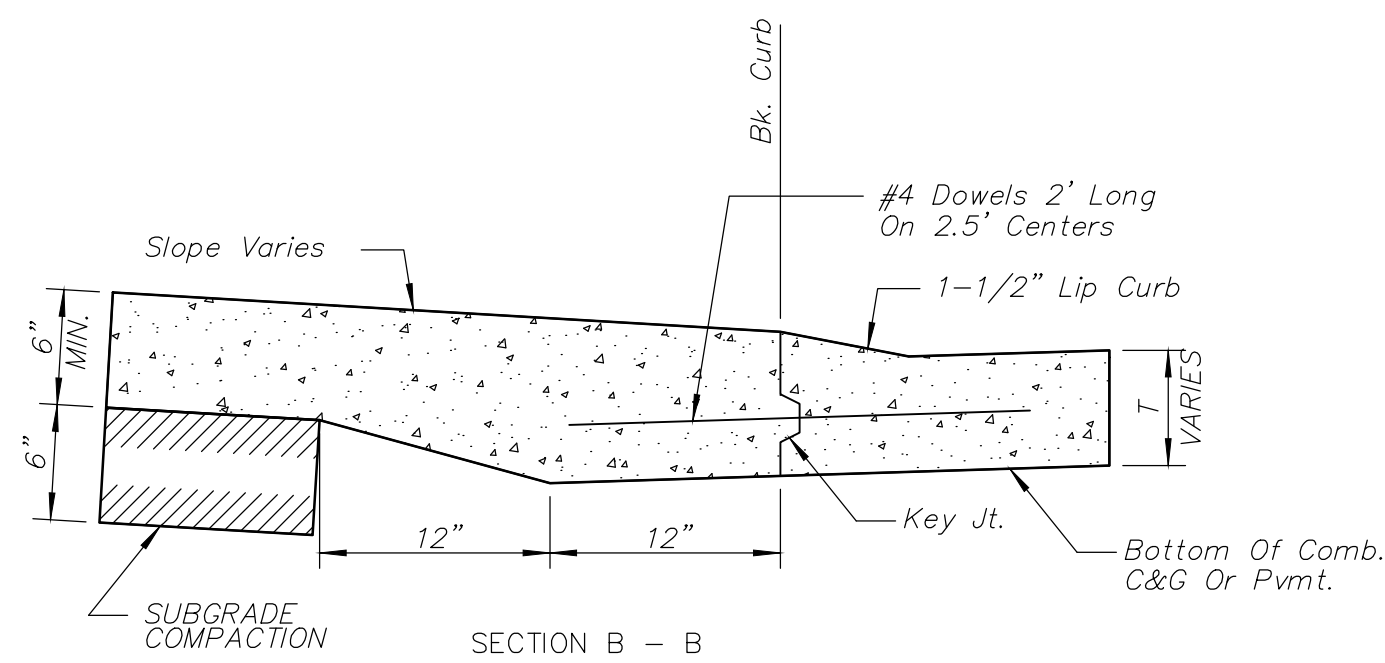

BACK OF CURB DETAIL

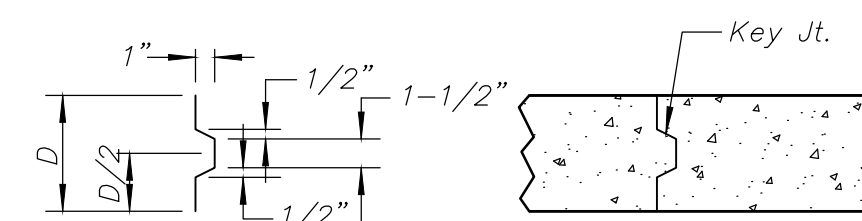

ALT. LONGITUDINAL CONSTRUCTION JOINT

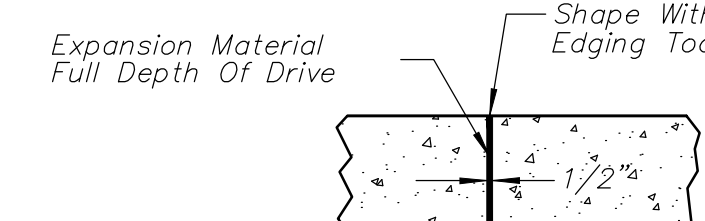

EXPANSION JOINT (E.J.)