

END ELEVATION (TYPE I)

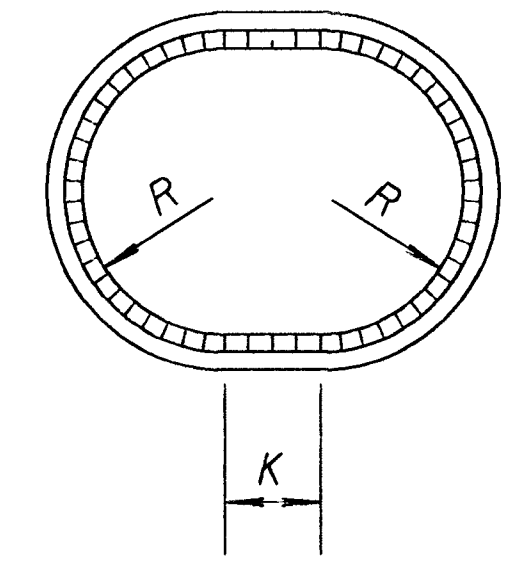

SECTION A-A
Showing rounding of inside edge of end section.

END ELEVATION (TYPE III)

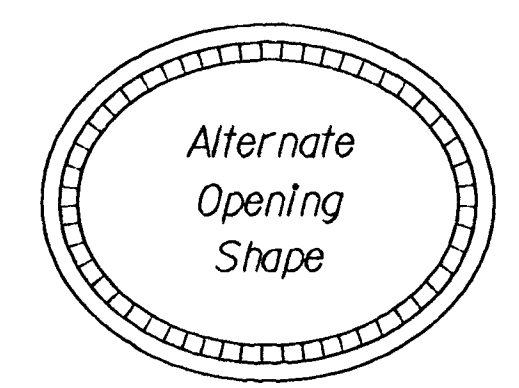
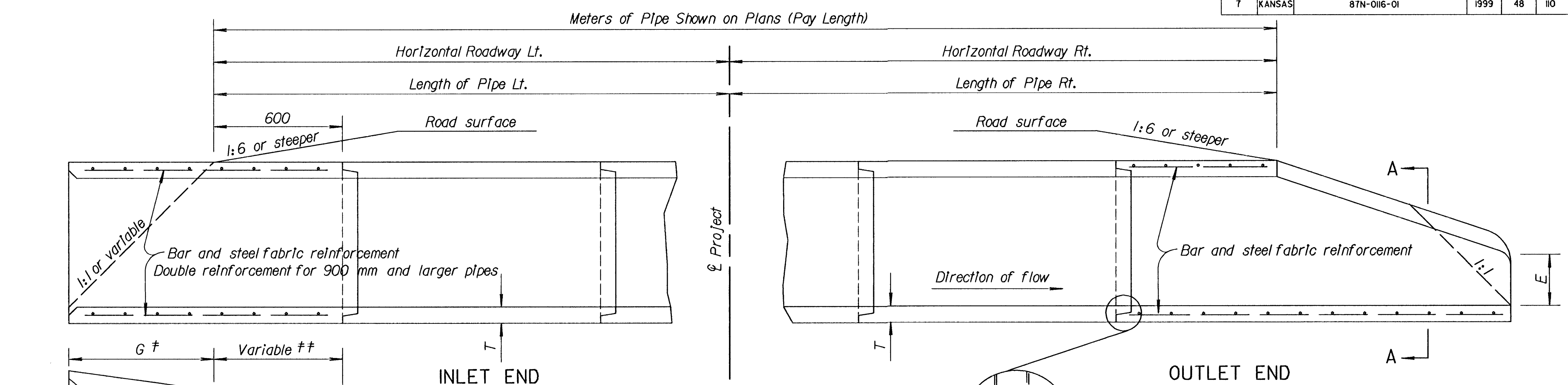

ELEVATION SECTION

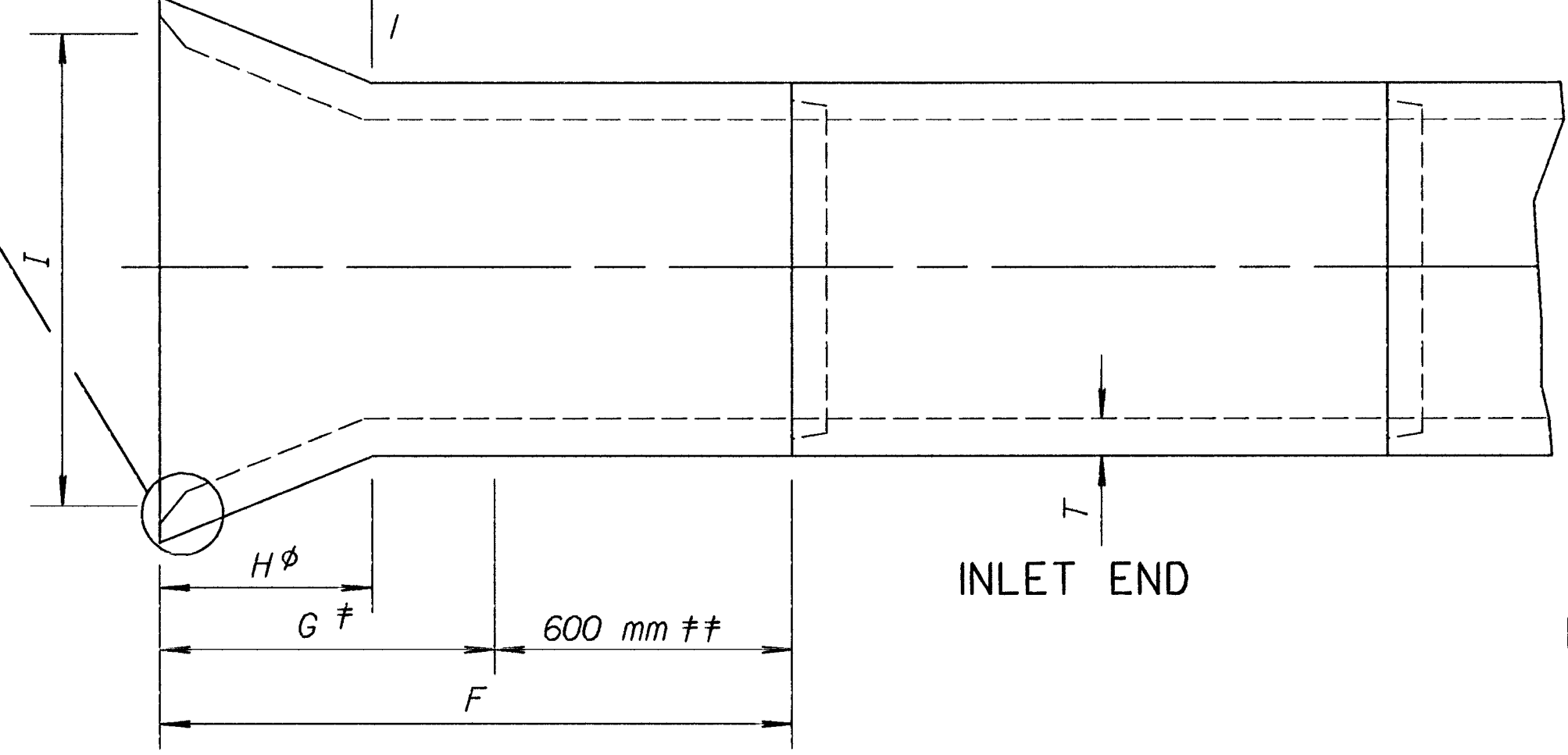
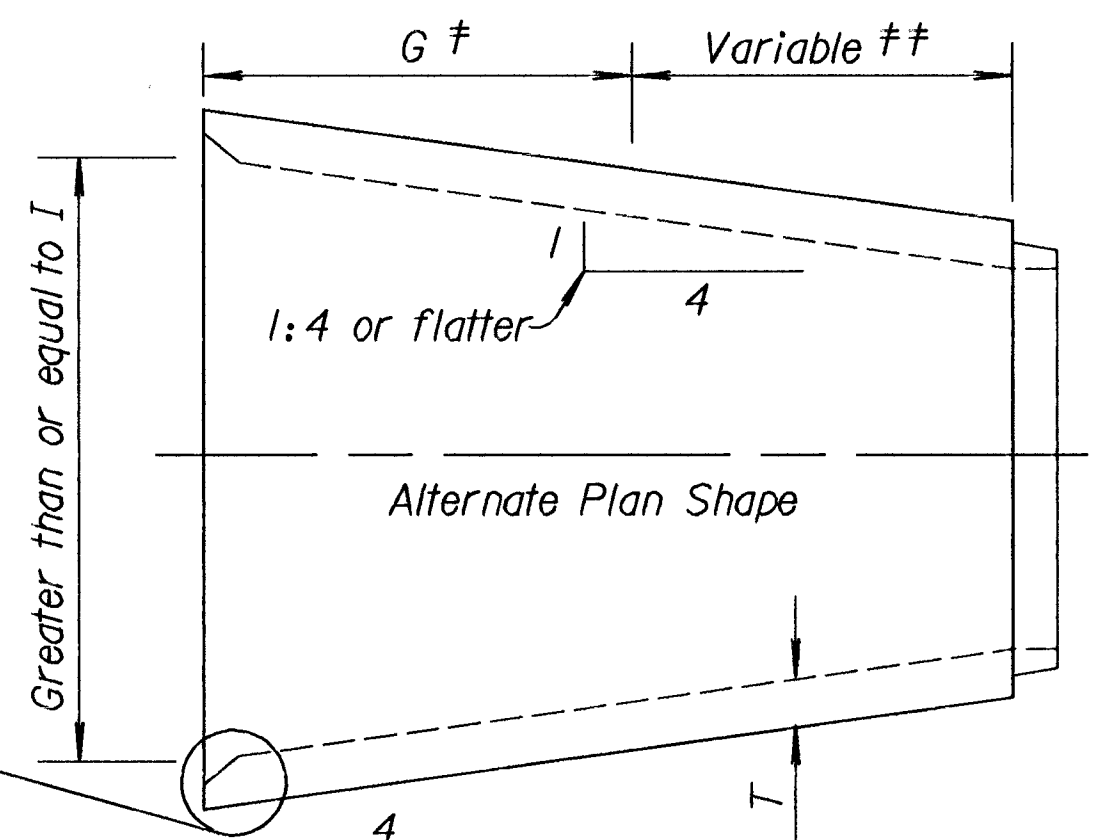

PLAN VIEW

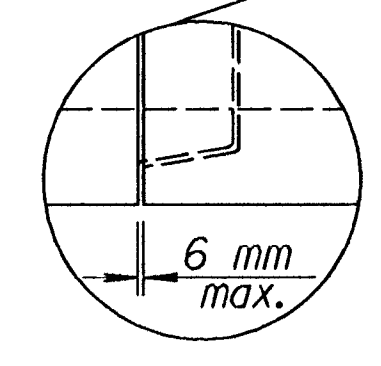

Note: Gain in length due to joint fit tolerance will not be paid for.

- ∅ Transition to round pipe.
- † Paid for as separate item of End Section, except when structures are bid as alternates. In that case End Sections shall be subsidiary to bid item: "Drainage Structure No. "
- ‡ Included in pay length of pipe.
- * Minimum waterway area is calculated at the inside of the bevel.

Diam.	A	B††	C†	D	E	R ₁	Slope	T
300	1 850	1 240	610	610	100	230	1:3	50
375	1 855	1 170	685	760	150	280	1:3	57
450	1 855	1 170	685	915	230	300	1:3	63
600	1 865	760	1 105	1 220	240	355	1:3	75
750	1 870	500	1 370	1 525	300	380	1:3	88
900	2 485	885	1 600	1 830	380	510	1:3	100
1 050	2 490	890	1 600	1 980	535	560	1:3	113
1 200	2 490	660	1 830	2 135	610	560	1:3	125
1 350	2 495	845	1 650	2 285	685	610	1:2.4	138
1 500	2 515	990	1 525	2 440	890	610	1:2	150
1 800	2 515	535	1 980	2 745	915	610	1:1.86	175
2 100	2 835	535	2 300	3 050	915	610	1:1.6	200

Diam.	Min. W.W. Area m ² *	F	G	H	I	J	K	R	T
600	0.42	1 295	685	435	800	38	200	300	75
750	0.65	1 460	850	545	1 005	51	255	375	88
900	0.94	1 625	1 015	650	1 200	51	300	450	100
1 050	1.27	1 790	1 180	760	1 405	64	355	525	113
1 200	1.66	1 955	1 345	865	1 605	76	405	600	125
1 350	2.11	2 120	1 510	980	1 810	89	460	675	138
1 500	2.60	2 285	1 675	1 090	2 010	102	510	750	150
1 800	3.74	2 615	2 005	1 310	2 410	127	610	900	175
2 100	5.09	2 945	2 335	1 535	2 810	152	710	1 050	200

Station	Location	Type	Size	Crown Grade Elev.	Flow line		Horizontal Roadway		Degree of Rotation	Length of Pipe		Meters of Pipe	End Sects.																			
					LT.	RT.	LT.	RT.		LT.	RT.		Type I	Type III	Type IV	LT.	RT.	LT.	RT.													
See Schedule of Inlets and Manholes Sht. 47																																

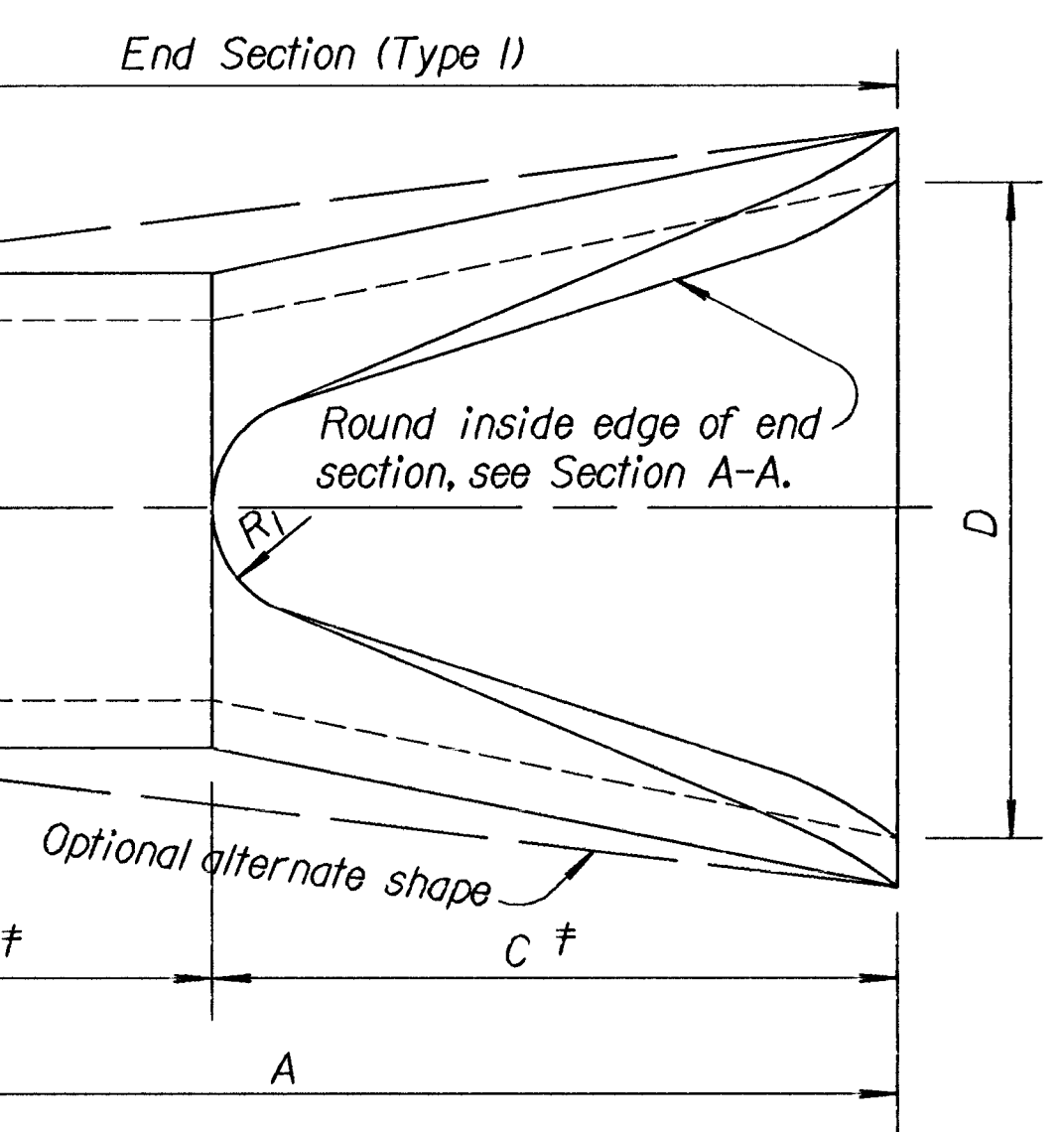

OUTLET END

Note: The culverts listed on this sheet may or may not indicate that the culvert installed will be reinforced concrete, steel, or aluminum.

NO.	DATE	REVISIONS	BY	APP'D
KANSAS DEPARTMENT OF TRANSPORTATION				
CONCRETE END SECTIONS FOR CONCRETE PIPES				
TYPE I & SIDE TAPERED INLET SECTION (TYPE III)				
RD712 SI				
FHWA APPROVAL	4-5-94	APP'D. James O. Brewer		
DESIGNED	TRACED	QUANTITIES	Bowser	
DESIGN CK.	DETAIL CK.	QUAN. CK.	Seitz	

Drawn By: \$\$\$\$\$\$ Plotted: \$\$\$\$\$\$ TIME \$\$\$\$\$\$ File: \$\$\$\$\$\$

Dimensions for alternate shapes shall be equal to or greater than those shown in the table, unless otherwise shown.