

FIRE HYDRANTS REQUIRED				
STATION	BURY LINE ELEVATION	TOP OF PIPE BURY ELEVATION	FIRE HYDRANT EXT. REQUIRED (ft)*	VALVE STEM REQUIRED (ft)*
11+71.11	1277.06	1273.35	4.0'	-

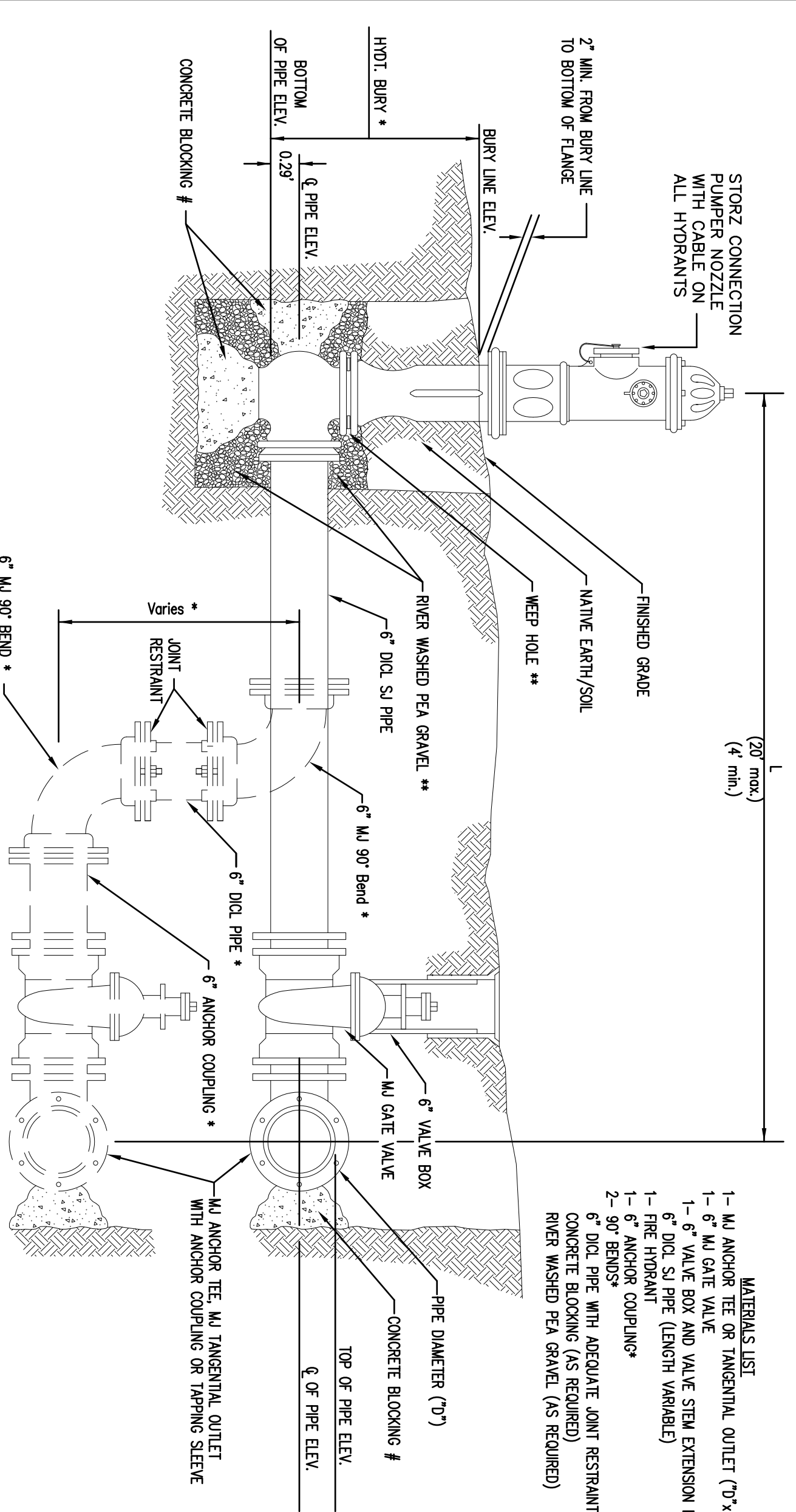

* IF THE REQUIRED HYDRANT BURY IS IN EXCESS OF 5', BUT LESS THAN 7', CONTRACTOR SHALL USE STANDARD 5' HYDRANT BURY AND HYDRANT BARREL EXTENSIONS AS NECESSARY. IF THE REQUIRED HYDRANT BURY IS GREATER THAN 7', CONTRACTOR SHALL USE 5' HYDRANT BURY, 2'-MU 90° BENDS, 6" ANCHOR COUPLING AND 6" DIA. PIPE AS NECESSARY FOR VERTICAL ADJUSTMENT. THE CONTRACTOR SHALL PROVIDE ADEQUATE THRUST BLOCKING AT HYDRANT AND METALS, OR SIMILAR RESTRAINT BETWEEN 90° BENDS TO SECURE ALL FITTINGS DURING TESTING AND OPERATION. THE CONTRACTOR SHALL PROVIDE A VALVE STEM EXTENSION PER DETAIL THIS SHEET.

** CAUTION: WEEP HOLES TO BE KEPT CLEAR DURING CONSTRUCTION AND BACKFILL. CONCRETE FOR THRUST BLOCKING SHALL NOT OBSTRUCT WEEP HOLES. PLACE 1 CUBIC FOOT OF RIVER WASHED PEA GRAVEL AROUND EACH WEEP HOLE.

CONCRETE THRUST BLOCKING SHALL BE KEPT CLEAR OF BOLTS, NUTS, AND MU ACCESSORIES. PER CITY OF WICHITA SPECIFICATIONS

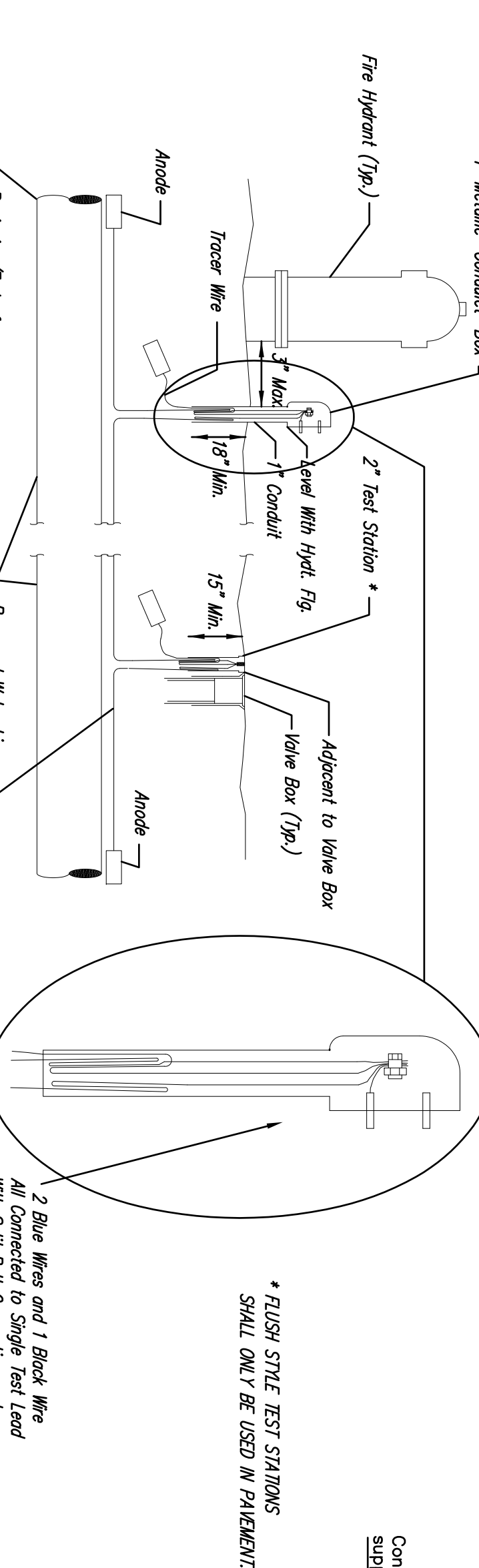

TRACER WIRE
Conductive type pipe locator/tracer wire shall be installed to locate all waterline pipe regardless of pipe material. The wire shall extend the entire length of the proposed pipe. The wire shall be taped to the waterline and pulled with the pipe. A waterproof connector shall be used at splice locations. Test stations shall be installed adjacent to all fire hydrants along the waterline and at blowoffs or valves near the ends of waterlines. Any exception to the location shall be approved by the engineer. At each test station, the tracer wire shall be connected to a 3 lb. Zinc or magnesium anodes. Anodes shall also be attached to the tracer wire at both the beginning and the end of the proposed waterline. A typical layout of the tracer wire and test station is provided in the above figure.

WIRE
The tracer wire shall be Blue No. 12 AWG CCS with 3045 mil HPPE insulation. The insulation shall be heat, oil, and gasoline resistant as manufactured by Temple Electric or approved equal. To allow for grade adjustment, a minimum of 12" of excess wire of all points of connection. Contractor shall attach wire being installed with proposed water main to any sheathing shall be removed such that 1" bare copper wire of all points of connection. Contractor shall attach wire being installed with proposed water main to any tracer wire installed with adjacent waterline projects.

TEST STATIONS
A complete list of approved Tracer Wire can be found on City of Wichita's website at www.wichita.gov. The test station for the hydrant applications shall be a 1 inch galvanized conduit style test station as manufactured by AGR Industries with a removable solid cover having two leads extending from the face or approved equal. The test station for valve applications shall be 2 inch flush style test station 12PS2B as manufactured by HANDELTY Industries or approved equal. The conduit style test station shall be attached to a 1 inch rigid galvanized conduit with a minimum length of 36" and plastic end bushing. The flush style shall have the word "WATER" stamped or molded into the lid. All test stations shall be manufactured using modded blue tops or sufficiently coated with blue enamel paint. The tracer wire and the anode wire shall be installed to allow 10 inches of wire within the test station. In concrete environments such as sidewalks or in the downtown area the contractor shall use the flush style test station. The location of all test stations shall be approved by the engineer, recorded, and shown in the as-built drawings.

ANODES
The anodes shall be 3 lb. bare zinc or magnesium. The anodes shall be buried at the same elevation as the waterline of each test station. The anodes shall be connected to 12 AWG CCS which shall be extended to the test station.

TRACER WIRE DETAIL

COST IS SUBSIDIARY TO PIPE INSTALLATION

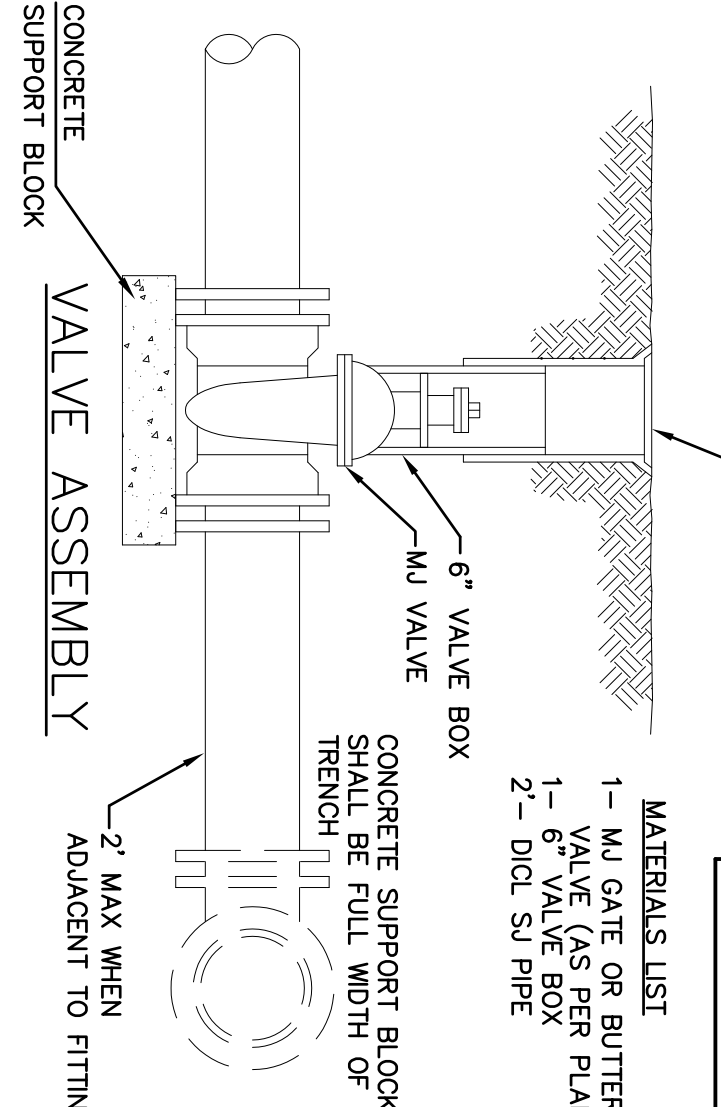

MATERIALS LIST
1-MU GATE OR BUTTERFLY VALVE (AS PER PLAN)
1-6" VALVE BOX
1-6" VALVE SUPPORT BLOCK
CONCRETE SUPPORT BLOCK SHALL BE FULL WIDTH OF THE TRENCH
CI CAP

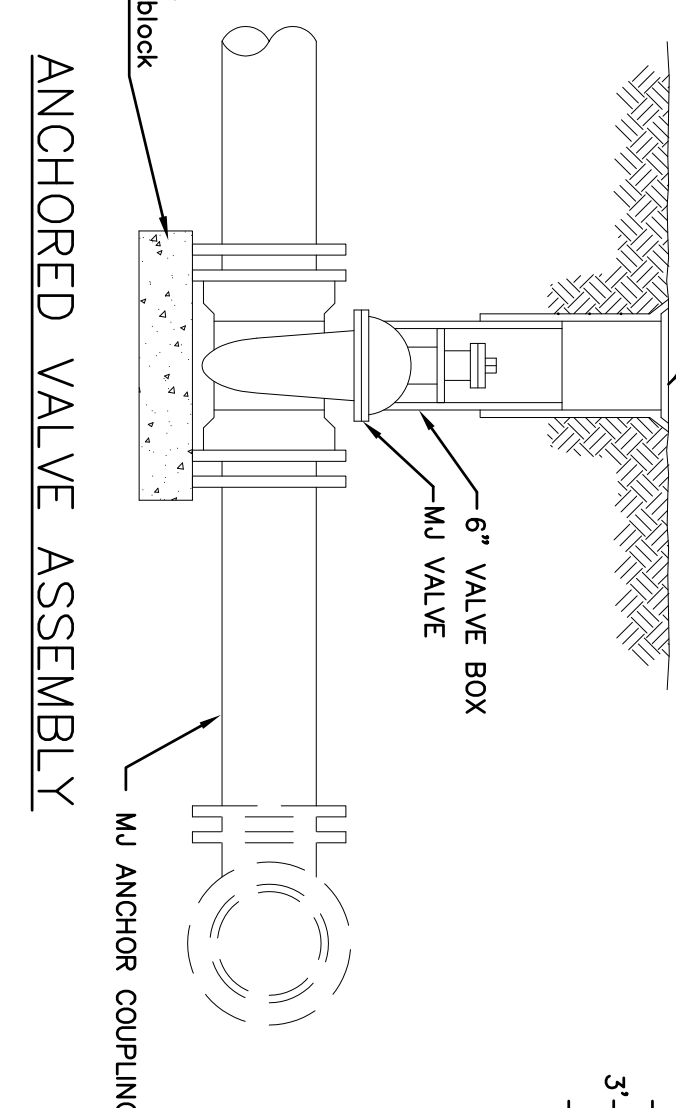

MATERIALS LIST
1-MU GATE OR BUTTERFLY VALVE (AS PER PLAN)
1-6" VALVE BOX
1-6" VALVE SUPPORT BLOCK
2- #6 REINFORCING BARS
CONCRETE SUPPORT BLOCK SHALL BE FULL WIDTH OF THE TRENCH

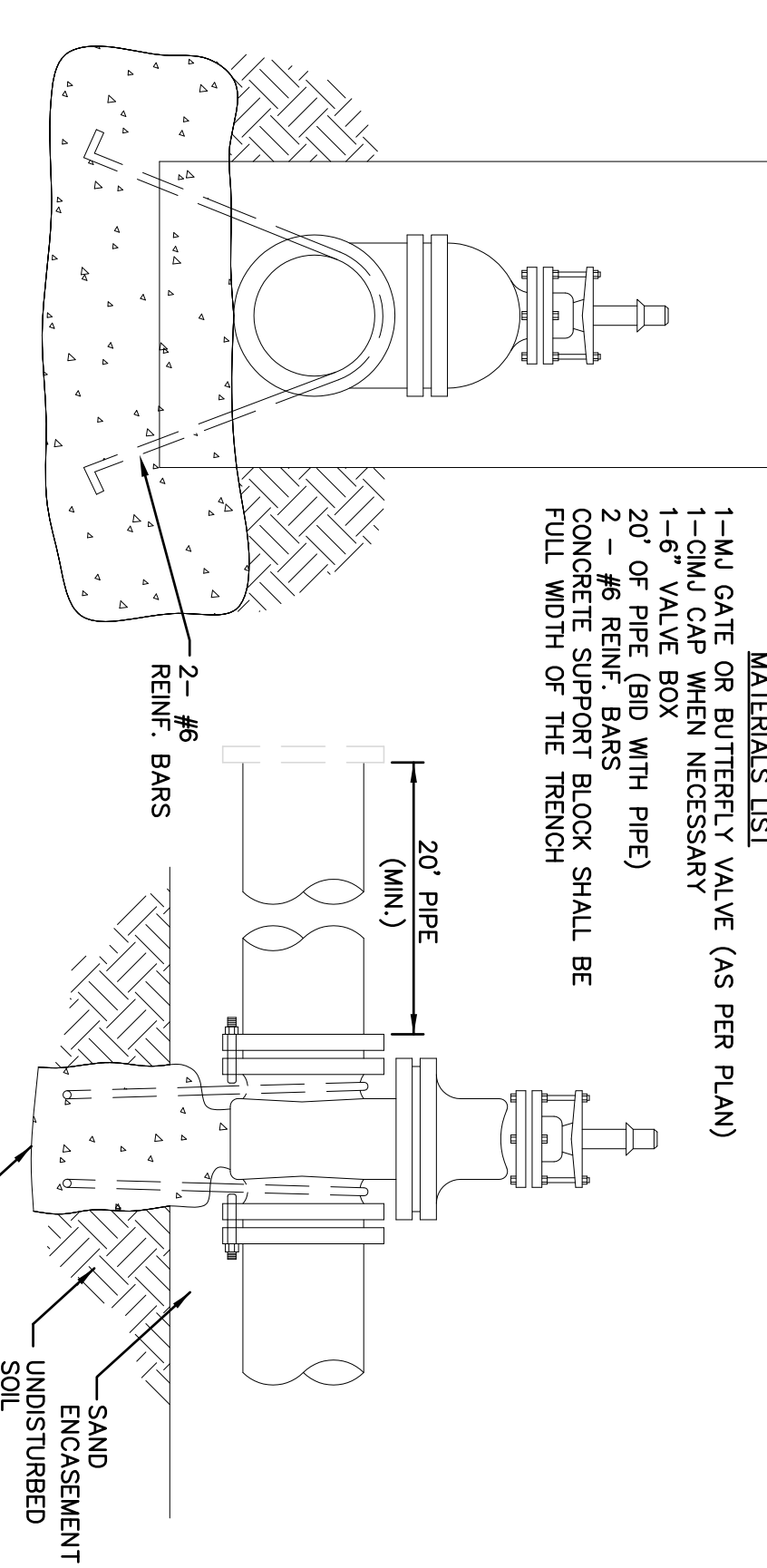

Notes:
1. Concrete Block at Valve to have sufficient bearing in undisturbed soil to prevent thrust movement as shown in table at right. Field Engineer to determine timing of undisturbed soil and final size of thrust block.
2. The thrust block shall be constructed such that bolts, nuts, and other MU accessories are kept clear of concrete.
3. All valves at dead ends and at other locations as called out on the plans shall be blocked as shown here.

THRUST AT VALVES	THRUST AT 150 #/ft²
4"	1809 lbs.
6"	4245 lbs.
8"	7540 lbs.
12"	16965 lbs.

ANCHORED VALVE ASSEMBLY, SPECIAL

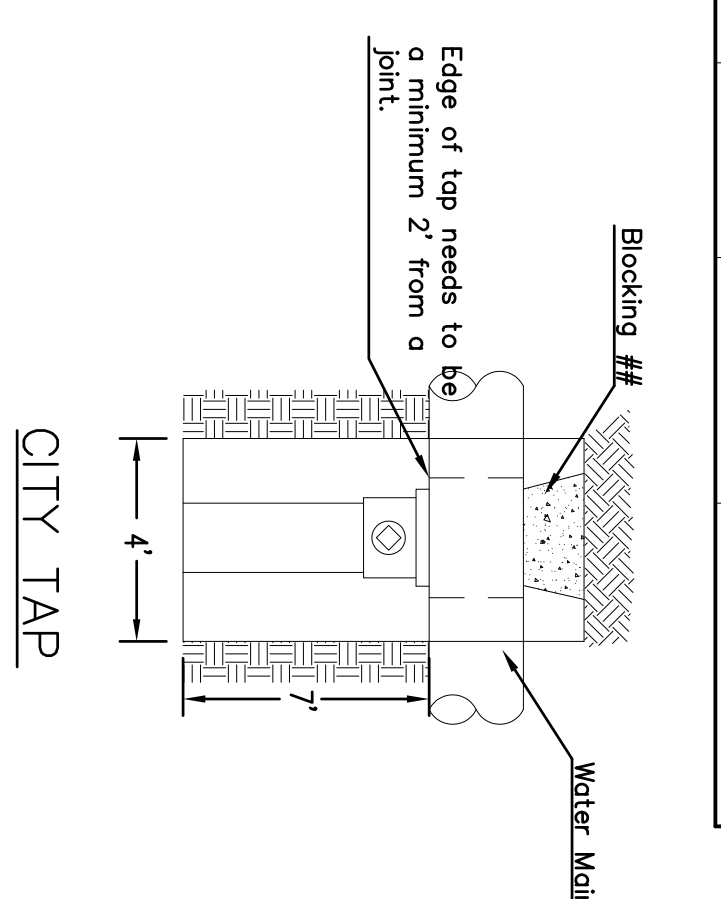

PROTECTIVE FILL DETAIL
MINIMUM PROTECTIVE FILL SHALL BE PROVIDED IN ALL INSTANCES WHERE COVER OVER THE PROP. WATER LINE IS LESS THAN 3" (COST SUBSIDIARY TO PIPE INSTALLATION)

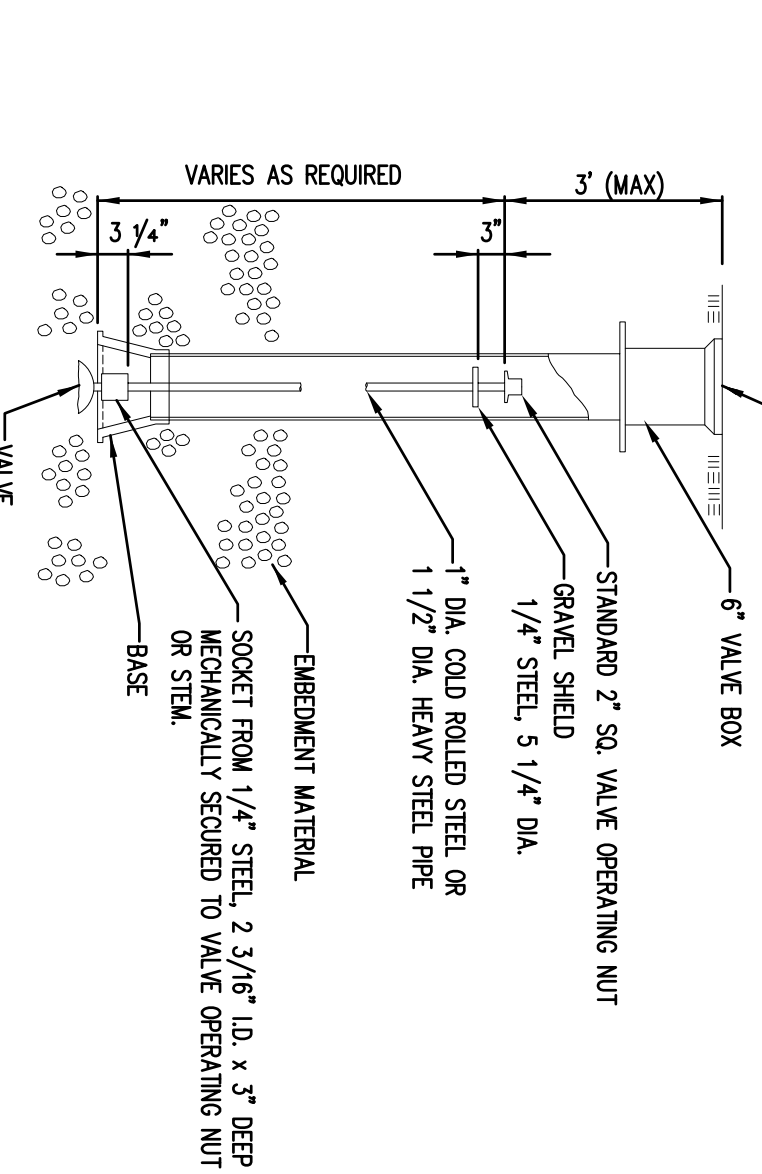

VALVE STEM EXTENSION DETAIL
NOTE: ONE VALVE STEM EXTENSION FOR EACH VALVE BURRED GREATER THAN 5'.

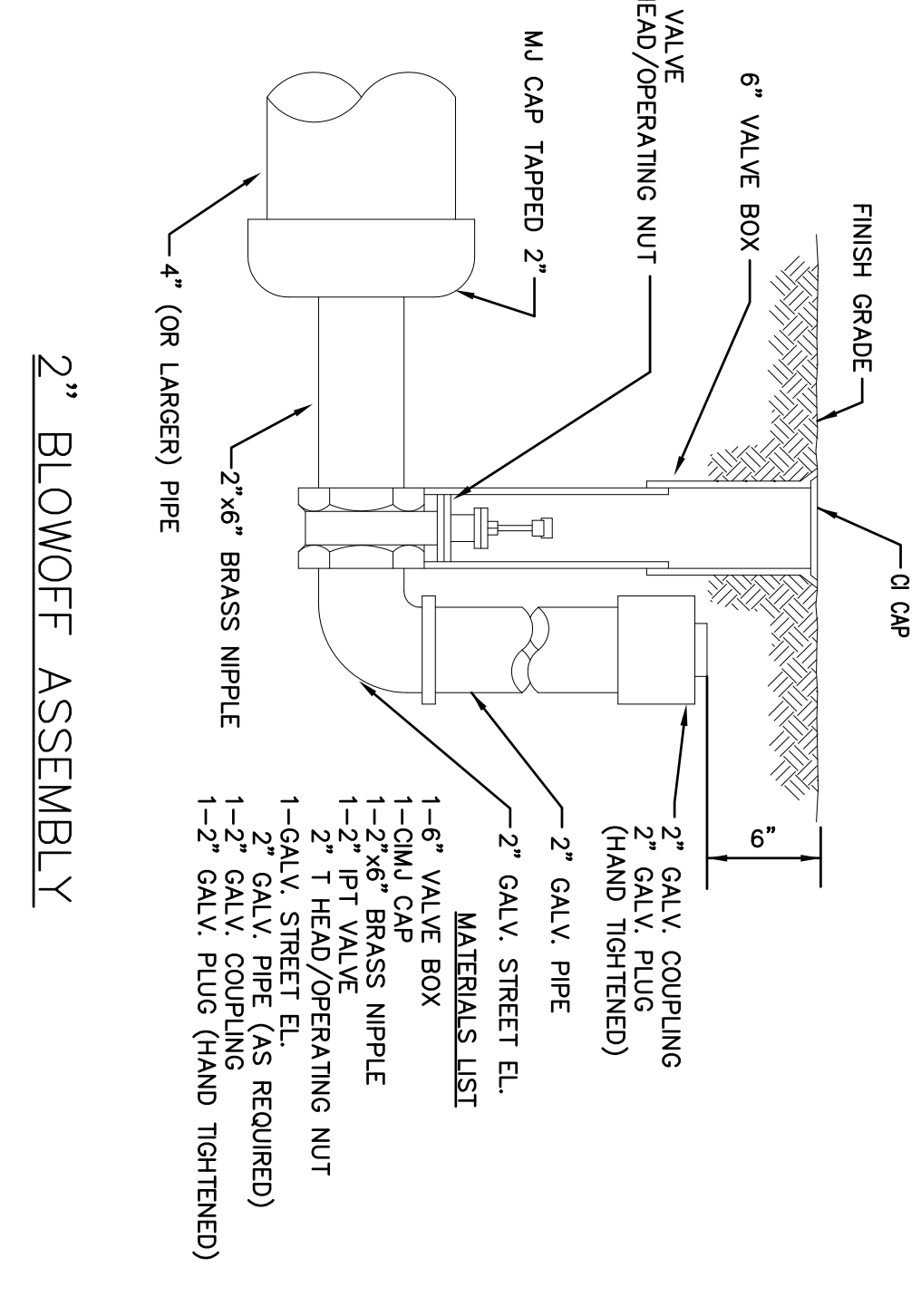

REVISED: JULY 2015

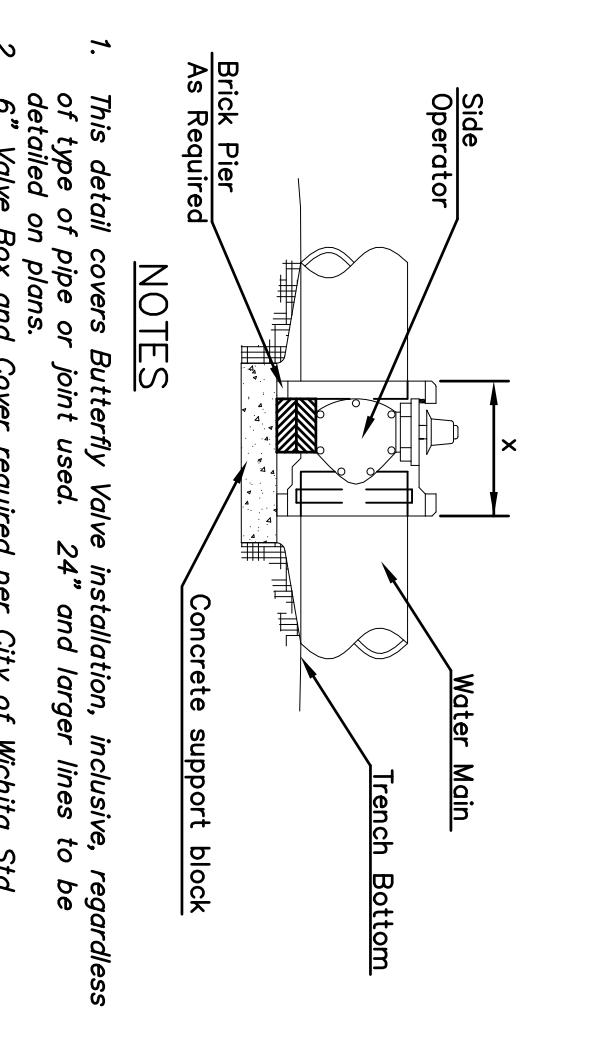

BUTTERFLY VALVE INSTALLATION
1. This detail covers Butterfly Valve installation, inclusive, regardless of type of pipe or joint used. 24" and larger lines to be detailed on plans.
2. 6" Valve Box and Cover required per City of Wichita Std.
3. Specifications.
3. Conc. Support Block to be full width of trench.



CITY OF WICHITA
PUBLIC WORKS & UTILITIES
ENGINEERING DIVISION

STANDARD WATER ASSEMBLY DETAIL
CITY ENGINEER
GARY JANZEN, P.E.

PROJECT NUMBER: OCA NUMBER: DATE: SHEET: 6 OF 13

FINAL
Engineer: J. DICKMAN
Designer: J. UNRUH
Dwg: P:\102106\102106-BASE
Job No: 102106
Date: 11/3/2015

POE & ASSOCIATES, INC.
CONSULTING ENGINEERS
544 West Douglas Avenue | Wichita, KS 67203
Phone 316/685-4114 | FAX 316/685-4444

CITY OF WICHITA, KANSAS
GARY JANZEN, P.E. - CITY ENGINEER
C.O.W. Project #468-85032; OCA #744397

No.	Date	By	Approved	Revision