

**TYPE 2 BARRICADE**

For rails less than 36" long, 4" wide stripes may be used. All stripes shall slope downward to the traffic side for channelization.

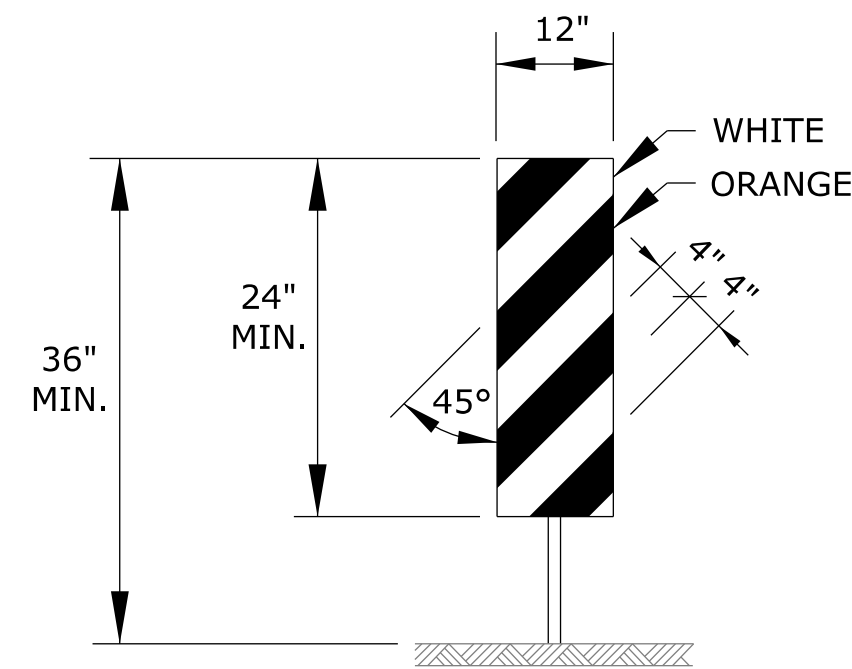

**VERTICAL PANEL**

The stripes shall slope downward to the traffic side for channelization.

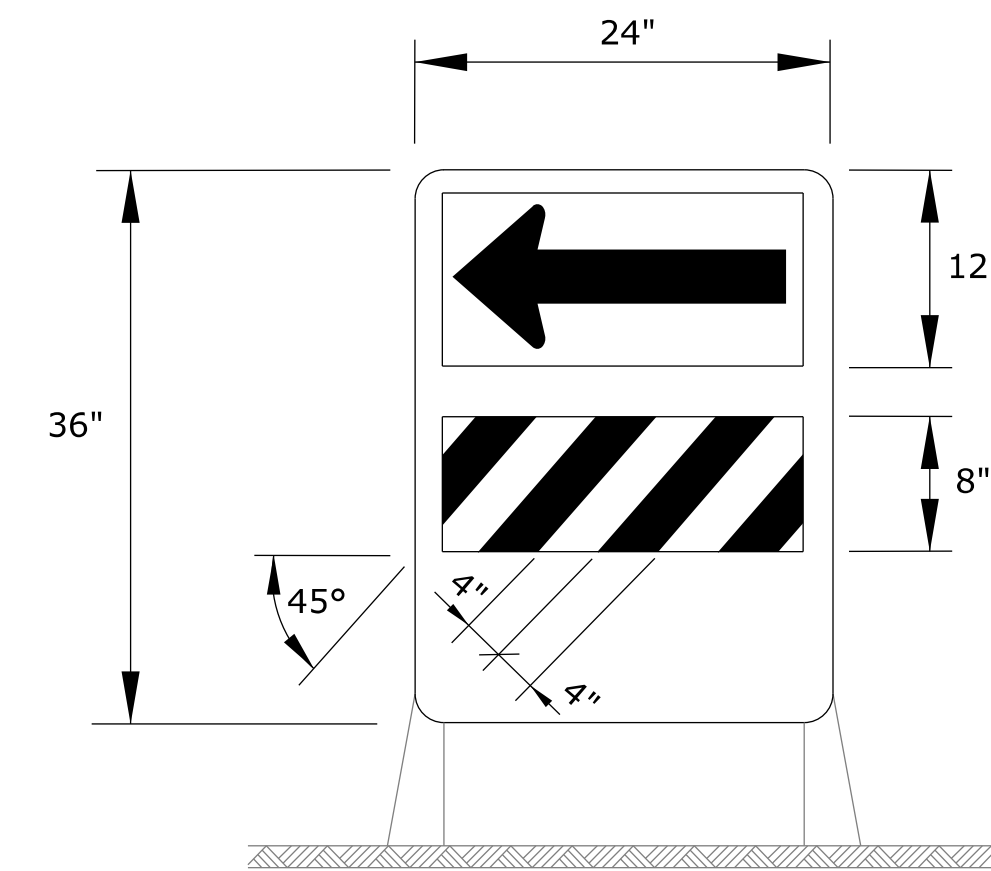

**DIRECTION INDICATOR BARRICADE**

The stripes shall slope downward in the direction traffic is to pass. The direction indicator barricade shall be used in series to direct the motorist into the intended lane of travel.

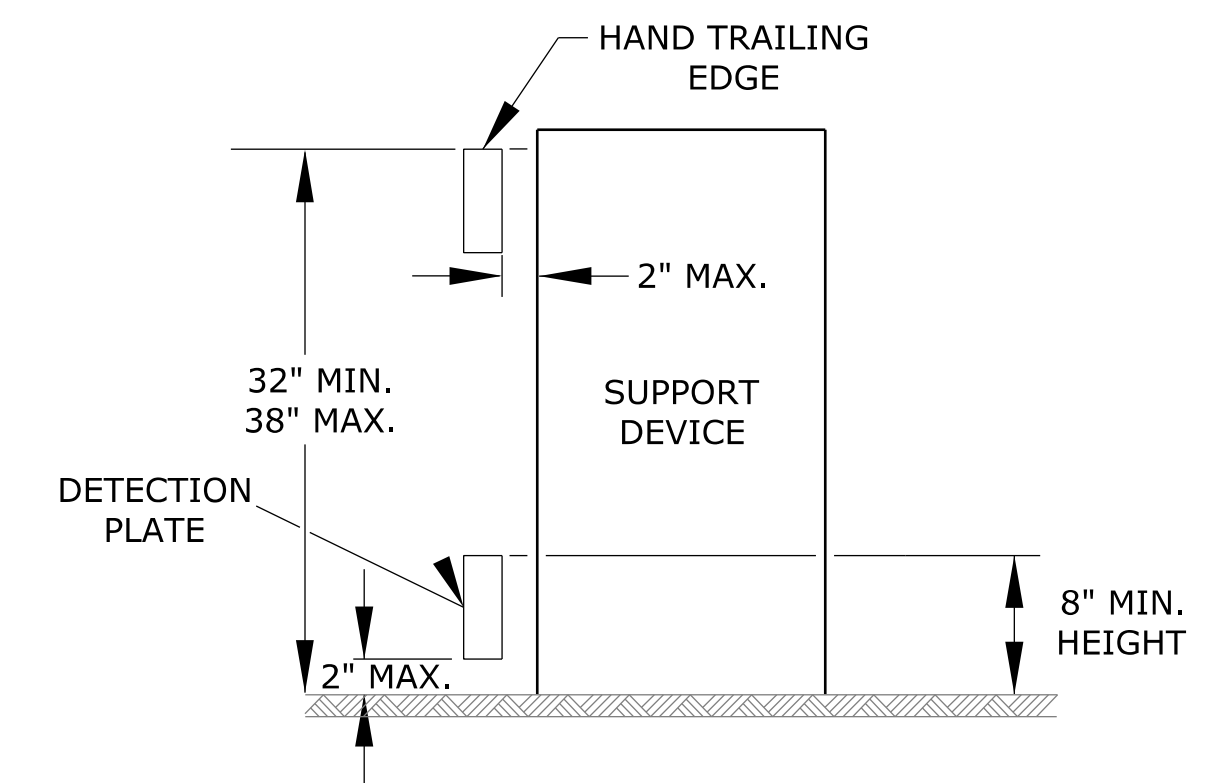

**PEDESTRIAN CHANNELIZER**

- Support device shall not project beyond the detection plate into the pathway.
- Hand trailing edges and detection plates are optional for continuous walls.
- Interconnect pedestrian channelizers to prevent displacement and to provide continuous guidance through or around work.
- Alternate pathways shall be firm, stable, and slip resistant.
- Treat height differentials > 1/2" in the surfaces of alternate paths with a firm, stable, and slip resistant temporary ramp having a slope of 12:1 or flatter and having a width equal to the alternate path.
- Use alternating orange/white on interconnected devices.

ITEM	LOCATION									
		Cross-overs	Shoofly Divisions	Tangents	Tapers	Ramps	Head to Head	Object Identifier	Lead-in Devices	Gores
PORTABLE	Drums	Yes	Yes	Yes	Yes	Yes	(1)	Yes	Yes	Yes
	Conical Delineators	Yes	Yes	Yes	Yes	Yes	(1)	Yes	Yes	Yes
	Vertical Panels	(2)	(2)	(2)	(2)	(2)	(1,2)	YES	(2)	(2)
	Direction Indicator Barricade	NO	NO	NO	Yes	NO	NO	NO	NO	NO
	Type 2 Barricade	(2)	(2)	(2)	(2)	NO	NO	Yes	NO	NO
FIXED	Traffic Cones	NO	NO	(4)	(4)	(4)	NO	(4)	(4)	(4)
	Tubular Markers	(3)	(3)	(3)	NO	(3)	Yes	NO	Yes	Yes
	Vertical Panels	(3)	(3)	(3)	(3)	(3)	(3)	Yes	(2,3)	(2)

- Not allowed on centerline delineation along freeways or expressways.
- The stripes shall slope downward to the traffic side for channelization.
- May be used upon the approval of the engineer.
- Daytime operations only.

3					
2					
1					
NO.	DATE	REVISIONS	BY	APP'D	

**KANSAS DEPARTMENT OF TRANSPORTATION**

**TRAFFIC CONTROL CHANNELIZING DEVICES**

TE702

FHWA APPROVAL	06/01/15	APP'D	Kristino Ericksen
DESIGNED	L.E.R.	DETAILED	R.W.B.
DESIGN CK.	DETAIL CK.	QUAN. CK.	TRACE CK.