

PLOTTED: Thursday, April 21, 2016 @ 04:17PM

J:\PROJECTS\2015\15010\0623\_COWI\_REUSE\_WATER\_SUPPLY\_SYSTEM\150623\_CAD\SHOTS\05\_CIVIL\PAVING\150623\_PAVING\_DETAILS.DWG

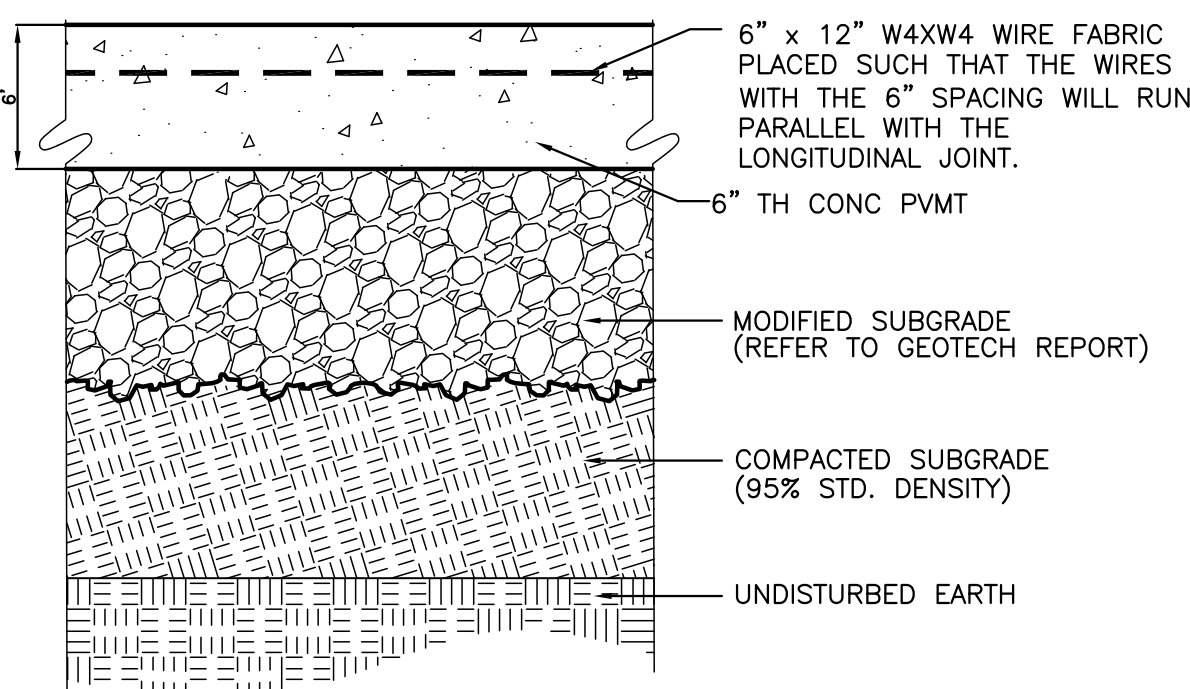

**1 TYP SECTION: 6" CONC. PVMT.**  
SCALE: 1 1/2" = 1'-0"

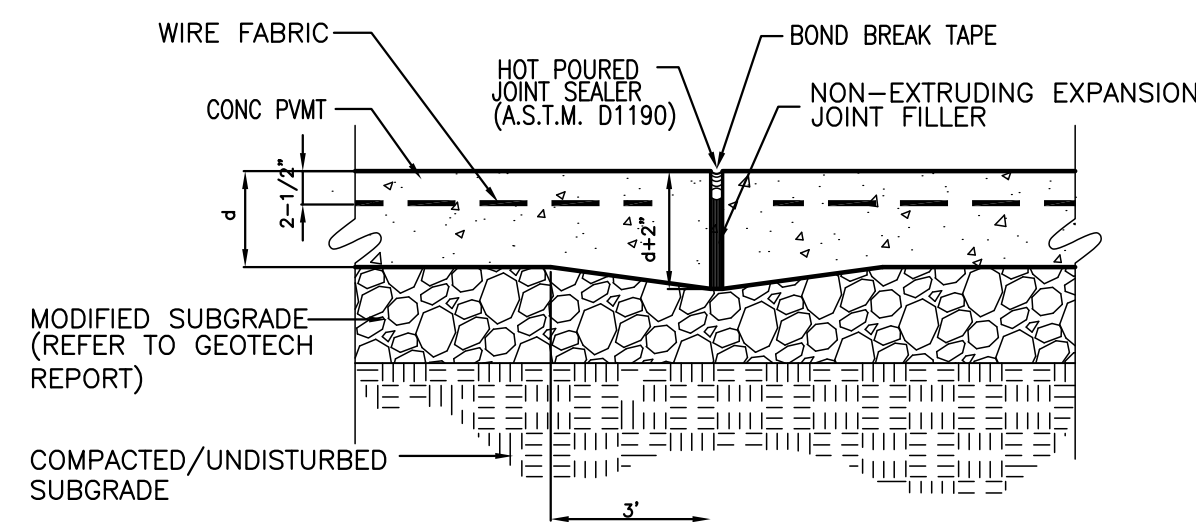

**2 EXPANSION JOINT DETAIL**  
SCALE: 1 1/2" = 1'-0"

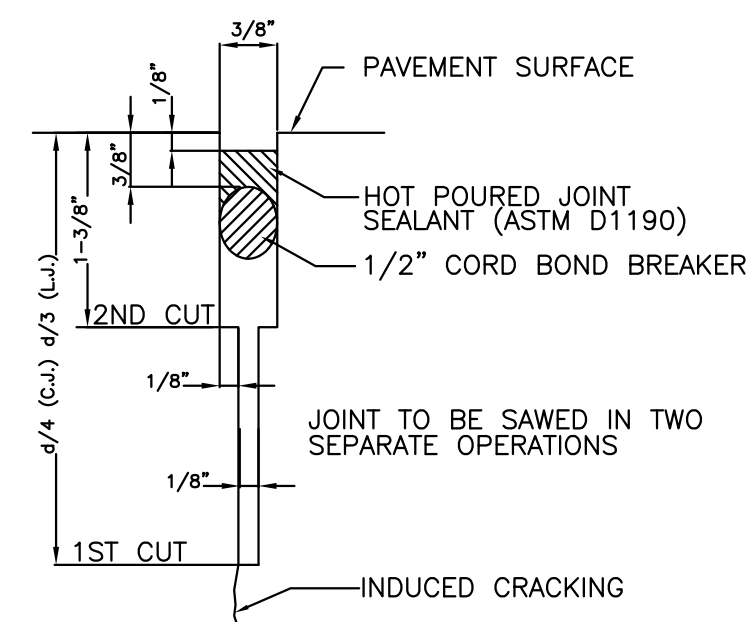

**3 SAWCUT JOINT DETAIL**  
SCALE: 1-1/2" = 1'-0"  
(VEHICULAR PAVMT. ONLY)

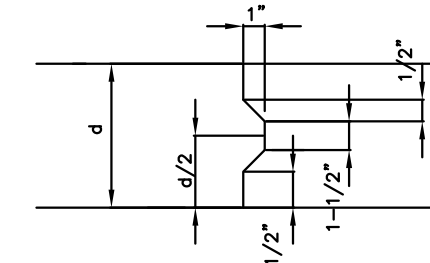

**4 KEYWAY DETAIL**  
SCALE: 1-1/2" = 1'-0"

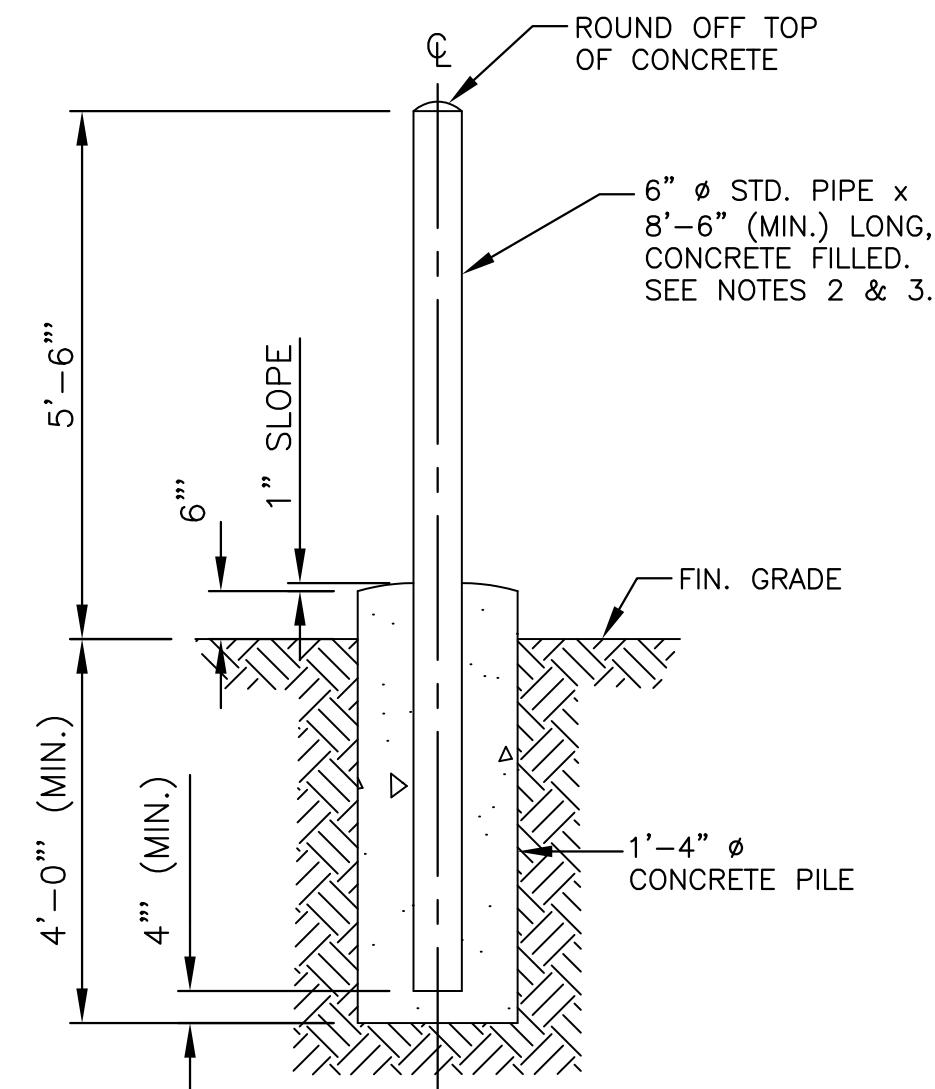

**11 BOLLARD DETAIL**  
SCALE: NTS

- BOLLARD NOTES:**
1. CONCRETE STRENGTH 3600 psi MIN. AND CEMENT TYPE BY DESIGN REQUIREMENT.
  2. PIPE SHALL BE CLEANED & GIVEN ONE COAT OF RED OXIDE PRIMER BEFORE PLACING IN CONCRETE.
  3. EXPOSED PORTIONS OF PIPE SHALL BE GIVEN ONE COAT OF SAFETY YELLOW PAINT.

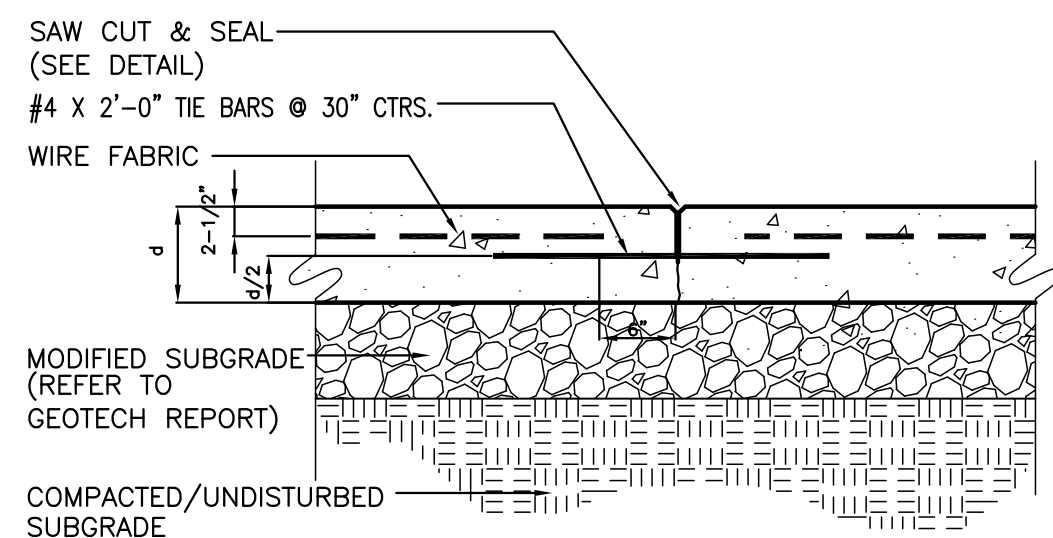

**5 LONGITUDINAL JOINT DETAIL (L.J.)**  
SCALE: 1-1/2" = 1'-0"

**GENERAL NOTE:**  
WHERE POSSIBLE A MONOLITHIC POUR INTEGRAL w/ FLATWORK IS PREFERRED OVER EXPANSION JOINT FILLER & SEALANT

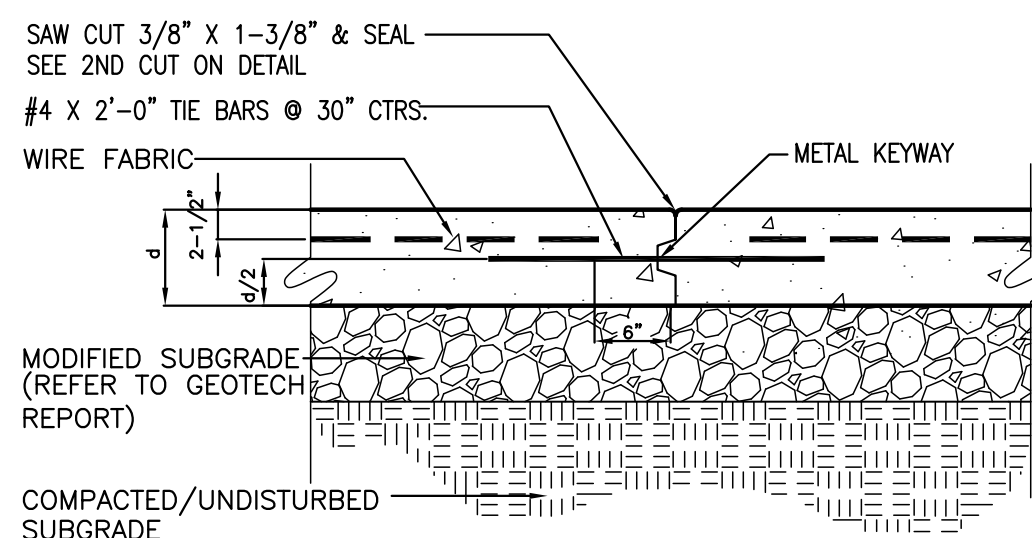

**6 OPTIONAL LONGITUDINAL JOINT (L.J.)**  
SCALE: 1-1/2" = 1'-0"

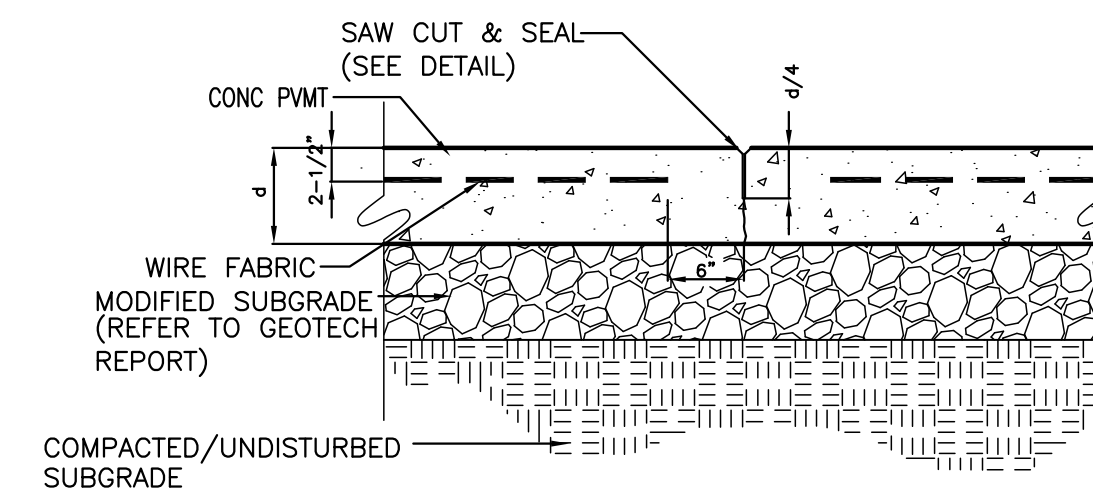

**7 CONTRACTION JOINT DETAIL (C.J.)**  
SCALE: 1-1/2" = 1'-0"

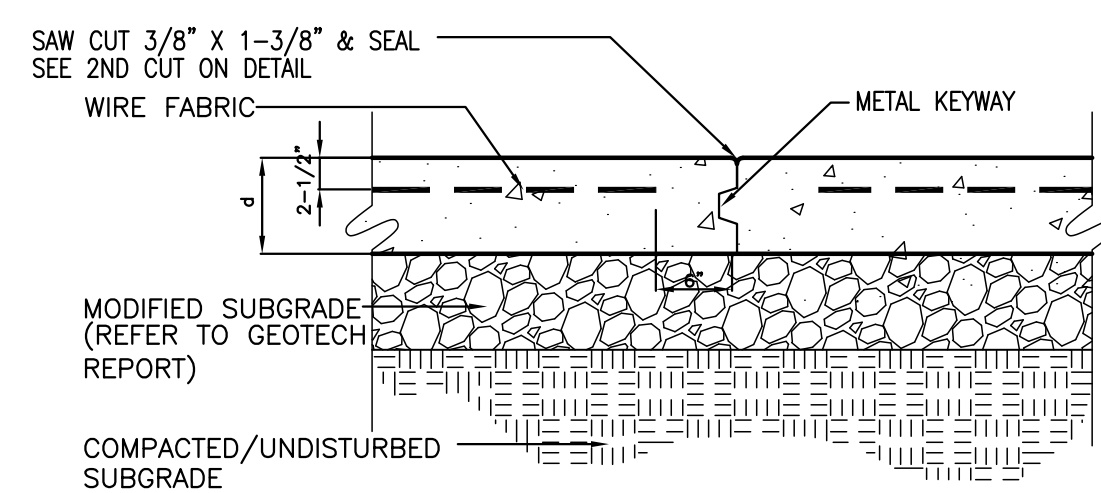

**8 OPTIONAL CONTRACTION JOINT (C.J.)**  
SCALE: 1-1/2" = 1'-0"

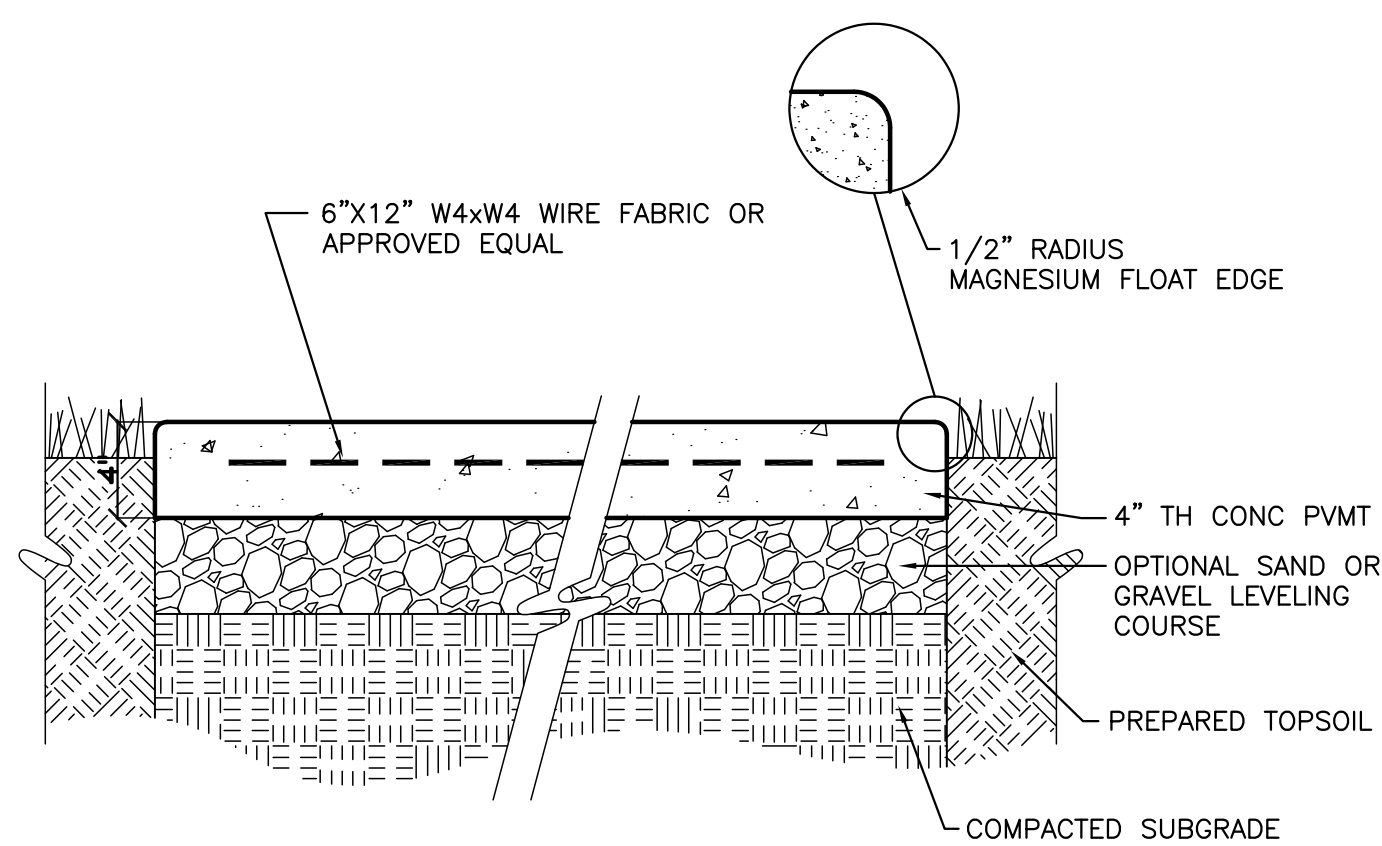

**9 4" CONC. SIDEWALK**  
SCALE: 1 1/2" = 1'-0"  
**GENERAL NOTE:**  
SIDEWALKS SHALL NOT EXCEED 5% SLOPE OR EXCEED A 2% CROSS SLOPE.

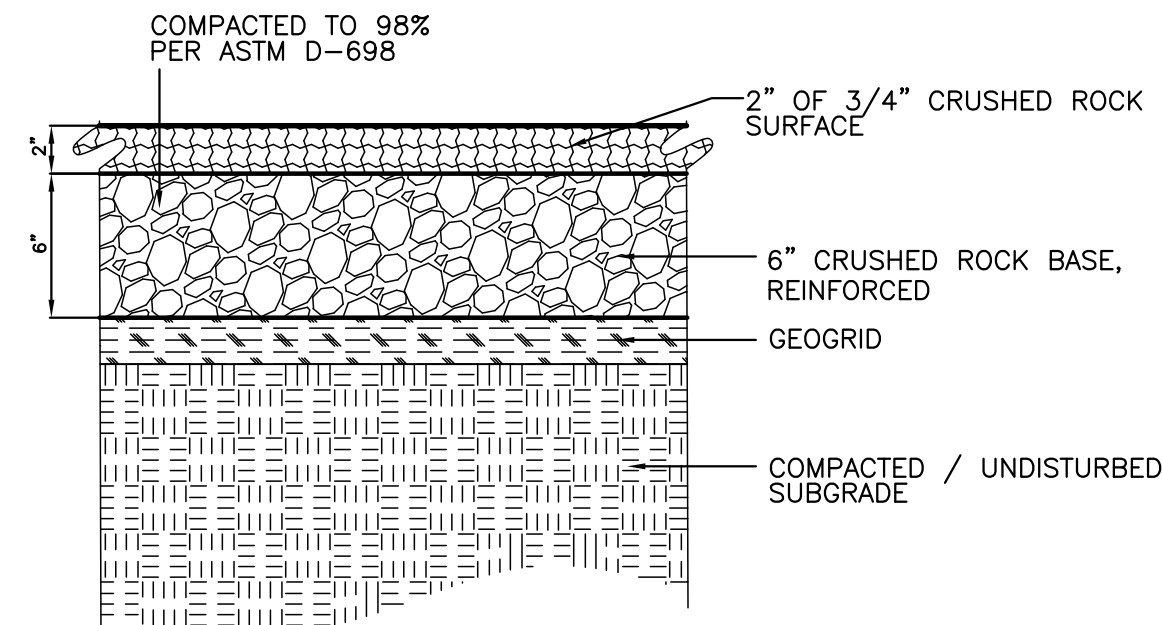

**10 GRAVEL SECTION**  
SCALE: NTS

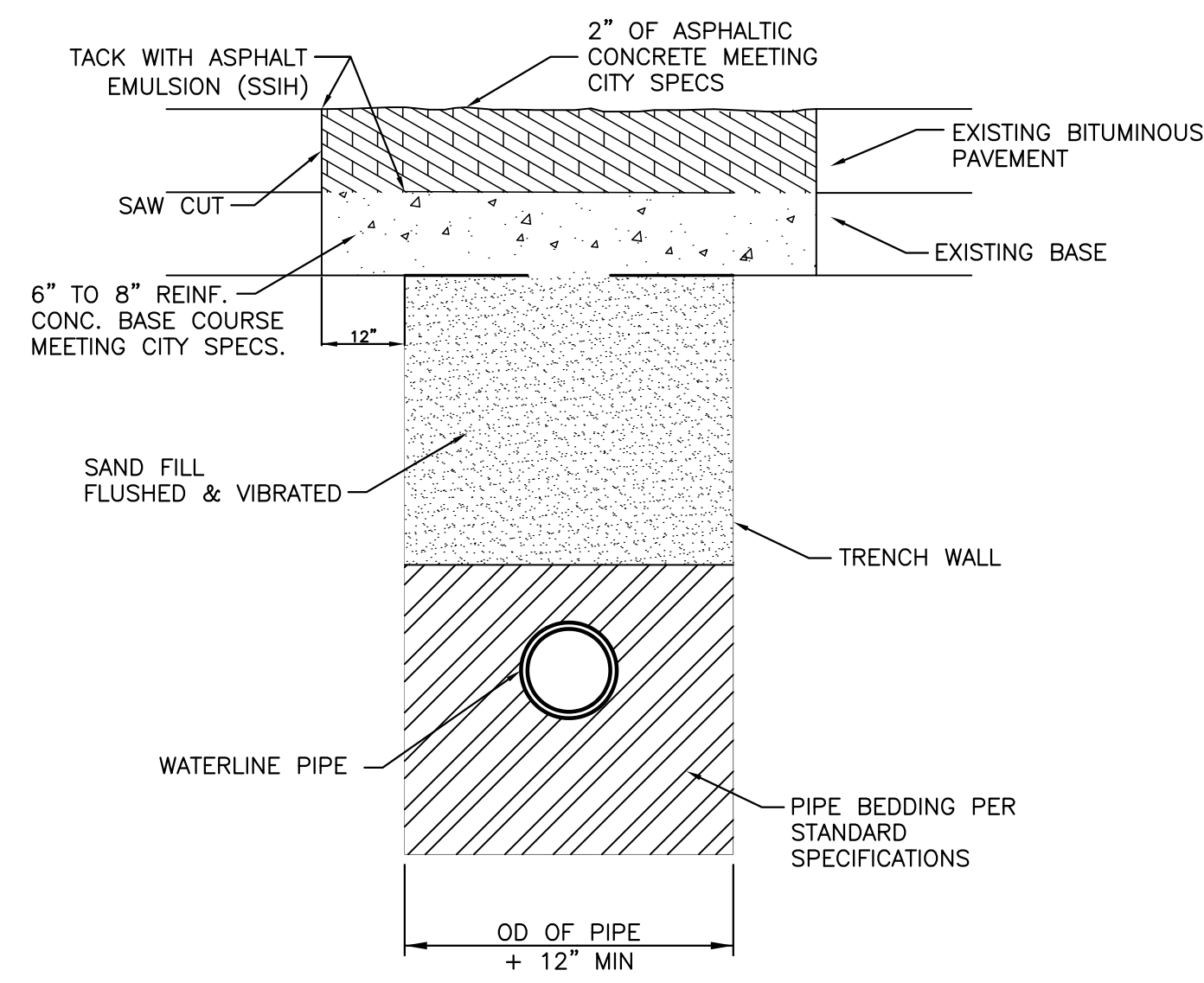

**12 PAVEMENT & TRENCH SECTION UNDER ROADS**  
SCALE: NTS



CITY OF WICHITA, KANSAS  
**RE-USE WATER PUMP STATION**  
TO SERVE SPIRIT AEROSYSTEMS

©2016 MKEC Engineering All Rights Reserved www.mkec.com  
These drawings and their contents, including, but not limited to, all concepts, designs, & ideas are the exclusive property of MKEC Engineering (MKEC), and may not be used or reproduced in any way without the express consent of MKEC.

PAVING DETAILS		
PROJECT NO.	468-85112	
DATE	04/18/16	
SCALE	AS NOTED	
DESIGNED	DRAWN	CHECKED
BLB	MCW	MAB
0	ISSUED FOR CONSTRUCTION	04/18/16
NO.	REVISION	DATE
SHEET NO.		
C3.1		

