

PLOTTED: Tuesday, April 05, 2016 @ 11:48AM

K:\CH\10264.dwg\PRINT\10264_PMD.DWG

SIGNING LEGEND

- Sign not part of project
- New sign on new post
- New sign on light post *
- Street Name Sign
- Traffic Sign

* Light post location may change.
Coordinate sign location with Engineer

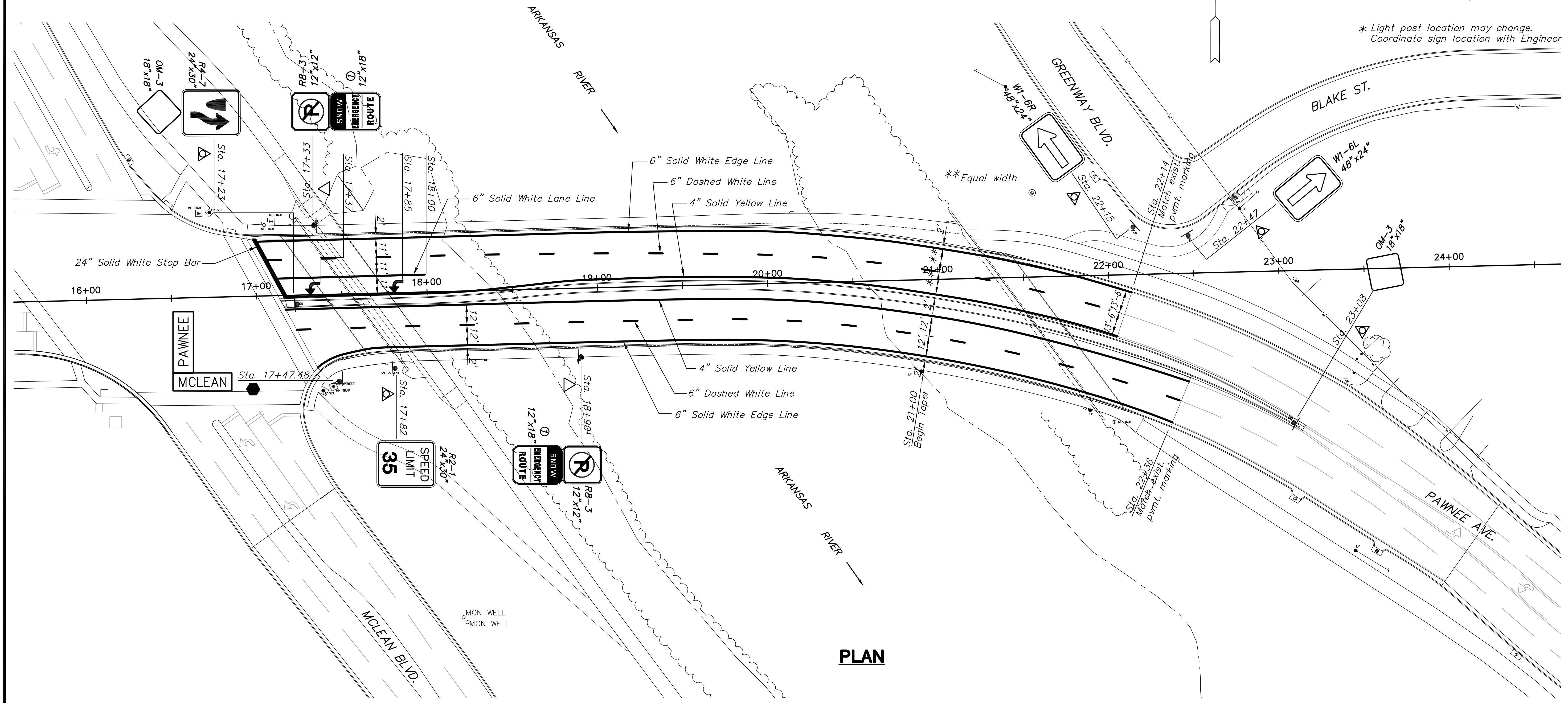
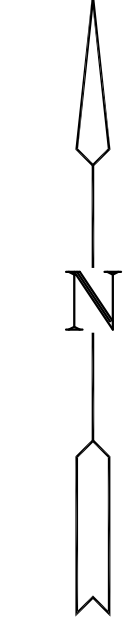
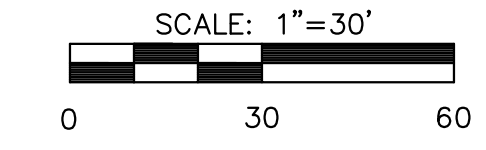

PLAN

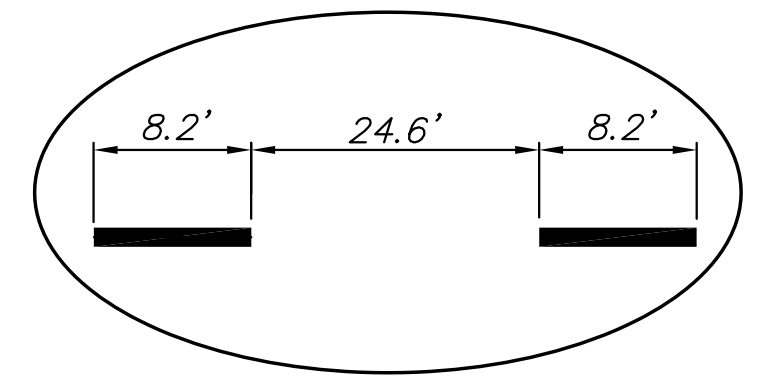

TYPICAL BROKEN LINE DETAIL

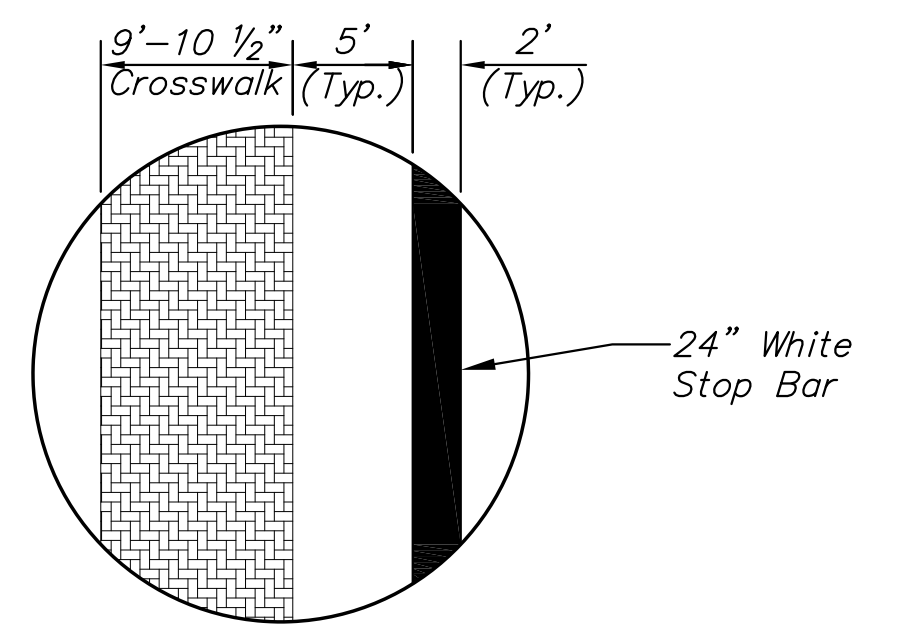

TYPICAL STOP BAR DETAIL

Pavement Markings - All pavement markings shall be epoxy, unless otherwise approved by the Engineer. Pavement markings shall be installed per manufacturer's recommendations and shall meet KDOT's 2007 Edition of the Standard Specification Section 806. Full traffic may not be restored (and substantial project completion achieved) until all pavement markings are in place. Should construction timing be such that restoration of traffic becomes necessary during temperatures prohibiting the installation of epoxy markings, the contractor shall install and maintain temporary markings until such time that epoxy markings may be properly installed. Except for the material requirement, temporary pavement markings shall be placed equivalent, in every manner (i.e. dimension, frequency, spacing, etc.), to the permanent marking layout. The cost for temporary pavement markings will not be paid for directly, but shall be considered subsidiary to the bid item for "Pavement Markings".

NOTE: Existing pavement markings for temporary traffic control purposes shall be replaced, in-kind on Pawnee beyond the limits of construction. Quantities for this are reflected in the Summary of Quantities.

SUMMARY OF QUANTITIES (FOR INFORMATION ONLY)		
ITEMS	QUANTITY	UNIT
Pavement Marking (White)(6")	1,468	L.F.
Pavement Marking (White)(24")	38	L.F.
Pavement Marking (Yellow)(4")	1,027	L.F.
Pavement Marking Symbol (Left Turn)	2	Each

RECAPITULATION OF QUANTITIES		
BID ITEM	QUANTITY	UNIT
Pavement Marking	1	L.S.



PAWNEE AVENUE BRIDGE OVER ARKANSAS RIVER BRIDGE REHABILITATION IMPROVEMENTS

©2013 MKEC Engineering All Rights Reserved
www.mkec.com
These drawings and their contents, including, but not limited to, all concepts, designs, & ideas are the exclusive property of MKEC Engineering (MKEC), and may not be used or reproduced in any way without the express consent of MKEC.

PAVEMENT MARKING AND SIGNING PLAN

PROJECT NO.	472-84922	
DATE	04/05/2016	
SCALE	1" = 30'	
DESIGNED	DRAWN	CHECKED
JRA	DPG	JRA
NO.	REVISION	DATE
SHEET NO.	38 OF 51	