

SCALE:
HORIZONTAL: 1" = 20'
VERTICAL: 1" = 5'

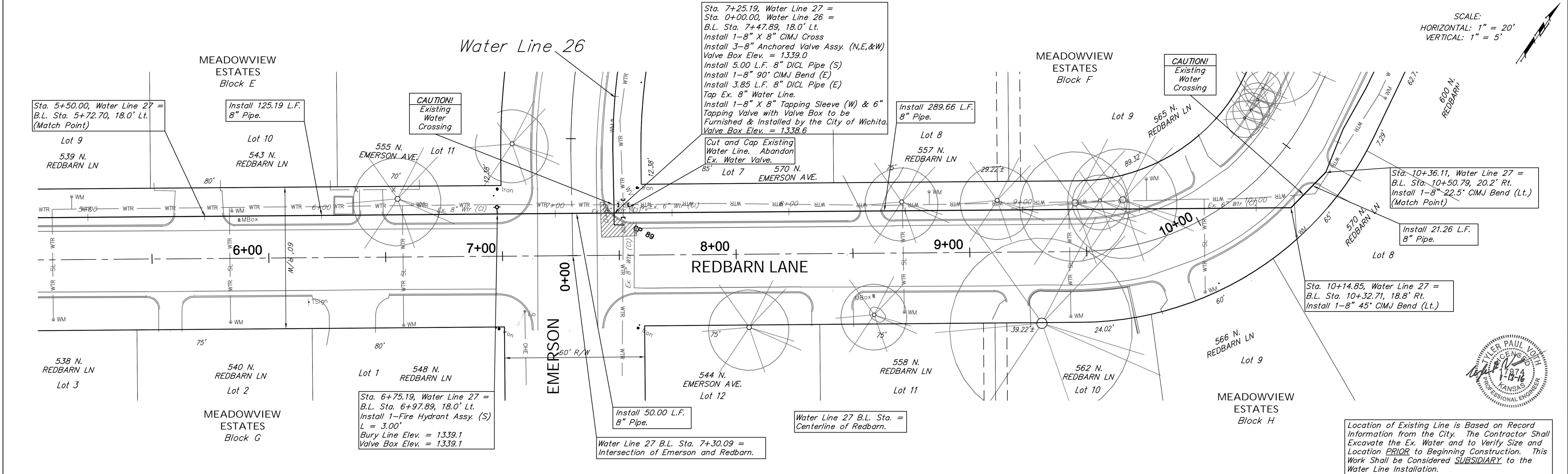

Location of Existing Line is Based on Record Information from the City. The Contractor Shall Excavate the Ex. Water and to Verify Size and Location PRIOR to Beginning Construction. This Work Shall be Considered SUBSIDIARY to the Water Line Installation.

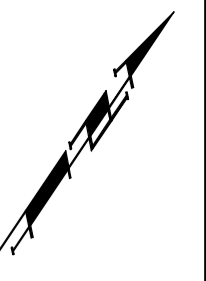