

PROJECT BENCHMARK

Chiseled square cut, center front face of inlet East side of Greenwich Road, 342 feet +/- South of the intersection of East 27th Street and Greenwich Road
 Project Elevation = 1377.42
 KDOT Elevation = 1378.05
 (Project Elevation is -.63 feet from KDOT)

BENCHMARKS:

TBM 1:
 Chiseled Square cut on E. Curb of island in center of Greenwich Road. Approximately 60' S. of intersection of westbound ramp to K-96.
 RIC Project Datum Elev. = 1373.08

TBM 2:
 Chiseled Square cut on south curb of 27th Street approximately 690 feet east of intersection of Greenwich Road.
 RIC Project Datum Elev. = 1378.40

TBM 3:
 Chiseled Square cut on south side of 27th Street approximately 330 feet east of intersection of Greenwich Road.
 RIC Project Datum Elev. = 1378.36

Water Distribution System to Serve WICHITA DESTINATION DEVELOPMENT - PHASE 6 LOT 1, K-96 Greenwich Addition

2728 N. Greenwich Court,
 2734 N. Greenwich Court &
 2740 N. Greenwich Court
 an Addition to Wichita, Sedgwick County, Kansas
 Gary Janzen, P.E., City Engineer
 1971 PPW (607853)

OWNER / DEVELOPER

Wichita Destination Developers, Inc.
 Attn: Michael J. Boyd, President
 1707 North Waterfront Parkway
 Wichita, Kansas 67206

CONSULTANT / APPLICANT

Renaissance Infrastructure Consulting
 1138 Cambridge Circle Drive
 Kansas City, Kansas 66103

INDEX OF SHEETS

01	Title Sheet
02	Final Plat
03	Final Plat
04	General Notes & Quantities
05	General Layout
06	Waterline Plan and Profile
07	Waterline Plan and Profile
08	Standard Details
09	Standard Details
10	Standard Details
11	Standard Details
12	Standard Details
13	Standard Details
14	Standard Details
15	Standard Details

U.S. PIPE DICL
 NORTHERN C-900 8"
 SIGMA FITTINGS
 CLOW FIRE HYD.
 (STORZ)
 CLOW VALVE

AS BUILTS

Contractor: McCullough Excavation, Inc. 8/11/2016	Project Inspector: Larry Gann KEMILLER ENGINEERING PA 117 E. Lewis, Wichita, KS 67202 (316)264-0242
--	--

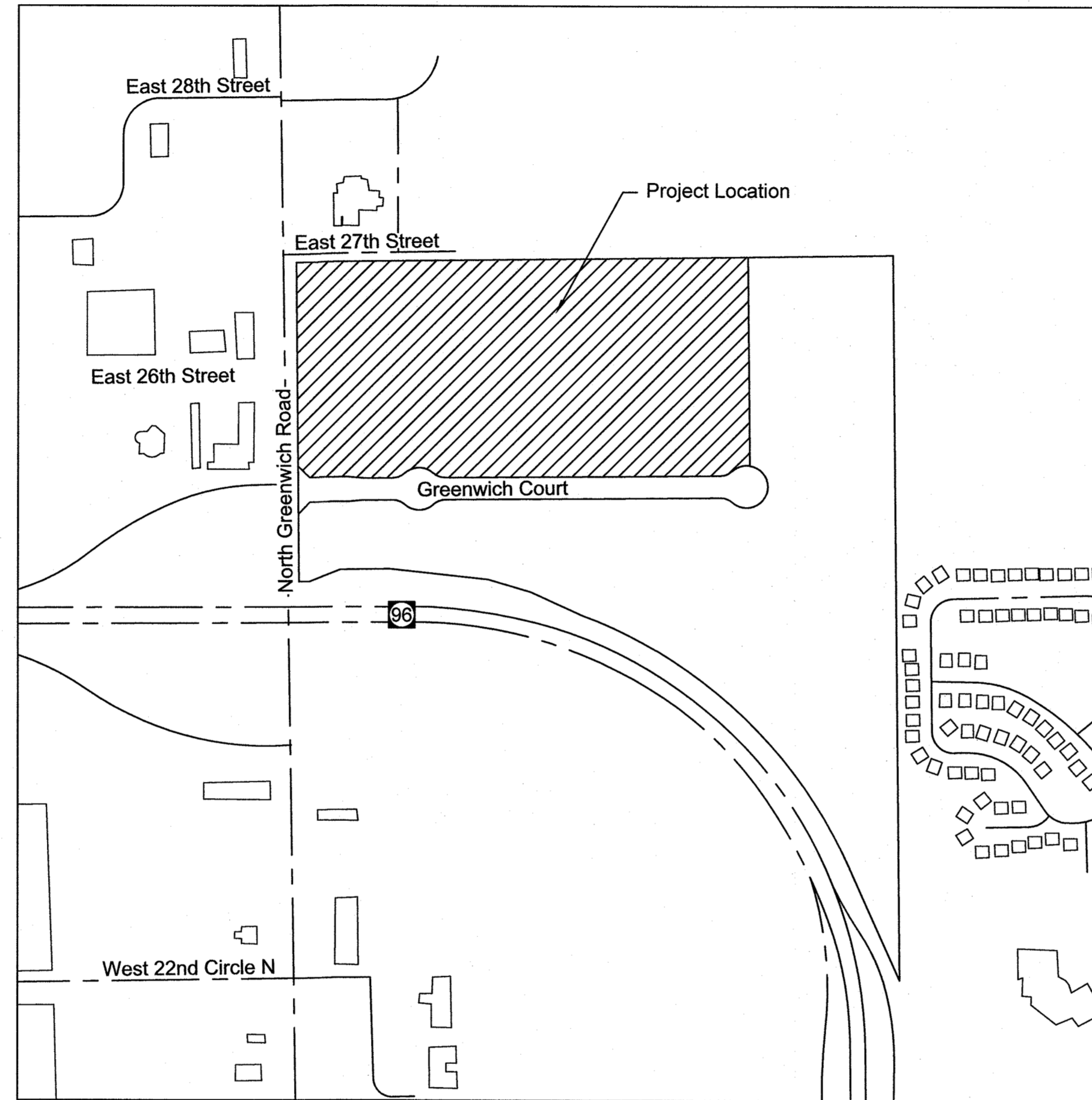

LOCATION MAP
 Scale: 1" = 500'

LEGEND

--- Existing Section Line	----- Proposed Right-of-Way
----- Existing Right-of-Way Line	- P/L - Proposed Property Line
----- Existing Lot Line	- L/L - Proposed Lot Line
----- Existing Easement Line	----- Proposed Easement
===== Existing Curb & Gutter	===== Proposed Curb & Gutter
===== Existing Sidewalk	===== Proposed Sidewalk
===== Existing Storm Sewer	===== Proposed Storm Sewer
□ Existing Storm Structure	□ Proposed Storm Structure
— WA — Existing Waterline	— A — Proposed Fire Hydrant
— GAS — Existing Gas Main	----- Proposed Waterline
----- Existing Sanitary Sewer	----- Proposed Sanitary Sewer
⊙ Existing Sanitary Manhole	• Proposed Sanitary Manhole
----- Existing Contour Major	----- Proposed Contour Major
----- Existing Contour Minor	----- Proposed Contour Minor
	----- Future Curb & Gutter

UTILITY SERVICE & INSTALLATION CONTACTS

KANSAS GAS SERVICE Attn: Tim Hamlin (316) 832-3121	WICHITA WATER Attn: Greg Lolley (316) 268-4334
WESTAR ENERGY Attn: Becky Thompson (316) 261-6320	AT&T Attn: Jason Edwards (316) 268-2008
BLACK HILLS ENERGY Attn: Daryl Keller (316) 941-1654	COX COMMUNICATIONS Attn: Mark Henderson (316) 260-7745

NUSTAR ENERGY L.P. Attn: Renee Davis (316) 721-7059	WICHITA SEWER Attn: LaDonna (316) 268-4329
--	---

UTILITY EMERGENCY CONTACTS

KANSAS ONE-CALL (316) 687-2470	AT&T 1-555-1212
COX COMMUNICATIONS (316) 687-2470	CITY OF WICHITA WATER DEPT (316) 268-4908
WESTAR ENERGY/ KANSAS GAS & ELECTRIC COMPANY (800) 482-4950	CITY OF WICHITA SEWER DEPT (316) 268-4071

AQUILA NATURAL GAS
 (316) 941-1608
 (800) 303-0357



MARCH 2016

APPROVED AS NOTED
 BY WICHITA PUBLIC WORKS ENGINEER
 AND WICHITA WATER & SEWER DEPARTMENT
 AND WICHITA FIRE DEPARTMENT

Engineering: *Reuben Dief* 3/27/16
 Utilities: *D. Jolly* 3/25-16
 Fire Dept: *GDW* 3/28/16

NOTE TO CONTRACTORS

Public Property:
 Inspection and Testing for the Waterline is to be Provided by a Licensed Consulting Engineering Firm under contract with the Owner/Developer. Said inspection is to be in accordance with the City of Wichita Standard Construction Engineering Practices and Certified by a Professional Engineer Licensed in the State of Kansas. No Work shall be performed in Dedicated Easements or Public Right-of-Way by the Contractor without Written Authorization by City Engineering. All Construction and Materials shall comply with the City of Wichita Specifications and Standards and Special Provisions (on file and Available in the City Engineer's Office).

Private Property:
 Installation and Testing for the Fire Protection line is to be Performed by a City of Wichita Licensed Fire Protection Contractor in Accordance with the Fire Codes as Adapted by the City of Wichita. All Materials and Construction Practices for the Fire Protection line shall comply with the Fire Codes as Adapted by the City of Wichita (Available from the City of Wichita Fire Department). The Contractor Shall not Commence work Without Notification and Approval of the Wichita Fire Department. Inspection of the Fire Protection Line is to be Provided by a Licensed Engineering Firm under Contract with the Owner/Developer and the Fire Department. The Contractor shall not Start Work until the Project Inspector is Assigned to the Project and Present on the Site. Any Work Done Without Inspection will be Required to be Uncovered for Inspection.

An Approved Copy of these Plans Signed by the City Staff are Required On-Site.

NO.	BY	DATE	AS PER CITY COMMENTS	AS PER CITY COMMENTS	ORIGINAL SUBMITTAL	REVISION
2.	JMD	MES 12/09/16				
1.	JMD	MES 12/02/16				
	JMD	MES 12/11/16				



Mar 09 2016 5:11pm Z:\RIC Design\2015\15-0196 Wichita K96 Strip Center ILLD\wp15-0196 PPW-Building Connections.dwg

46-156-71

FINAL PLAT

WICHITA DESTINATION DEVELOPMENT

AN ADDITION TO WICHITA, SEDGWICK COUNTY, KANSAS

A REPLAT OF ALL OF K96 AND GREENWICH NORTH ADDITION

CERTIFICATE OF SURVEY

I, Michael J. Schmidtberger, a registered land surveyor in Kansas, do hereby certify that I have been in responsible charge of surveying and platting of "WICHITA DESTINATION DEVELOPMENT" an addition to Wichita, Sedgwick County, Kansas, into Lots, Reserves and Streets the same being accurately set forth in the accompanying plat and described herein:

A replat of all of Lots 1 thru 7 inclusive, Block 1, Lots 1 thru 8 inclusive, Block 2, Reserves A, B, C, D, E, F and G, K96 AND GREENWICH NORTH ADDITION, an addition to Wichita, Sedgwick County, Kansas, together with WOODSPRING ST, WOODSPRING CIR., and BOULDER DR. platted rights-of-way.

All lots, blocks, streets, easements, setbacks, and access controls, together with all other public dedications or rights-of-way within the above described property are hereby vacated and replatted by virtue of K.S.A. 12-512b, as amended.

I hereby certify that the details of this plat are correct to the best of my knowledge and belief this 3rd day of April, 2015.

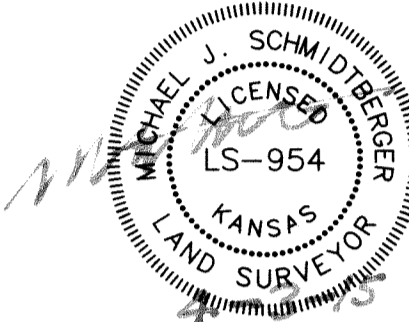

Michael Schmidtberger, Kansas LS-954
Renaissance Infrastructure Consulting
1138 W. Cambridge Circle Drive
Kansas City, Kansas 66103

OWNER'S CERTIFICATE

Know all men by these presents that we the undersigned property owner of the land above set forth in the Registered Land Surveyor's Certificate, has caused the same to be surveyed and platted into Lots, Blocks, Reserves, and Streets the same to be known as "WICHITA DESTINATION DEVELOPMENT," a replat K96 AND GREENWICH NORTH ADDITION, an addition to Wichita, Sedgwick County, Kansas.

This plat shall conform to the recitals of CUP DP-333.

Easements for the construction and maintenance of public utilities, drainage and sanitary sewer, as indicated on the accompanying plat are hereby granted to the public.

All streets are hereby dedicated to and for the use of the public.

A drainage plan has been developed for this plat. All drainage easements, rights-of-way, or reserves shall remain at established grades or as modified with the approval of the applicable City or County Engineer, and unobstructed to allow for the conveyance of stormwater.

All abutters rights of access to or from Greenwich Road, over and across the west line of "WICHITA DESTINATION DEVELOPMENT", are hereby granted to the appropriate governing body as indicated hereon. All abutters rights of access to or from Kansas Highway 96, over and across the south line of "WICHITA DESTINATION DEVELOPMENT", are hereby granted to the appropriate governing body as indicated hereon. Access controls are dedicated to and for the use of the public.

Lot 1, Block A, is required to adhere to the minimum pad elevation as shown on the "Minimum Pad Elevations" table.

Reserves "A", "B", "C", "D", "E", "F", and "G" are platted for monuments, signs, landscaping, berming, sidewalks, irrigation, open space, pavement, utilities confined by easements, and walls provided that they do not inhibit the conveyance of surface drainage. Reserves "A", "B", "C" are also platted for drainage, drives, and parking. Reserves "D", "E", "F" and "G" shall allow for public access across said reserves, at various locations for driveways, as approved by the City Engineer. The Reserves shall be owned and maintained by the Lot owner's association, provided however, that the undersigned or Lot owner's association as the undersigned successors in interest may, at its discretion deed parcels of said Reserves "A", "B", and "C" to an owner (s) of an adjoining lot subject to the obligation to maintain such deeded parcel in compliance with the provisions hereof and in compliance with the maintenance covenants of any applicable restrictive covenants or regulations.

Medical Practice Association Properties, LLC, a Kansas Limited Liability Company

Aaron Ryan
Aaron Ryan, Manager

STATE OF KANSAS)
) SS
COUNTY OF SEDGWICK)

This instrument was acknowledged before me on 9th day of April, 2015, by Aaron Ryan, Manager, Medical Practice Association Properties, LLC, a Kansas Limited Liability Company.

IN WITNESS WHEREOF, I have hereunto set my hand and affixed my official seal; the day and year last above written.



Carol M. Schulze, Notary Public
Notary Public: Carol M. Schulze
My Term Expires: May 5, 2017

Wichita Destination Developers, Inc., a Kansas Corporation

Michael J. Boyd
Michael J. Boyd, President

STATE OF KANSAS)
) SS
COUNTY OF SEDGWICK)

This instrument was acknowledged before me on 8th day of APRIL, 2015, by Michael J. Boyd, President, Wichita Destination Developers, Inc., a Kansas Corporation.

IN WITNESS WHEREOF, I have hereunto set my hand and affixed my official seal; the day and year last above written.



Ruth A. Glaze, Notary Public
Notary Public: Ruth A. Glaze
My Term Expires: 12-24-16

WDDMBB, LLC, a Kansas limited liability company

Michael J. Boyd
Michael J. Boyd, President

STATE OF KANSAS)
) SS
COUNTY OF SEDGWICK)

This instrument was acknowledged before me on 8th day of April, 2015, by Michael J. Boyd, President, WDDMBB, LLC, a Kansas limited liability company.

IN WITNESS WHEREOF, I have hereunto set my hand and affixed my official seal; the day and year last above written.



Ruth A. Glaze, Notary Public
Notary Public: Ruth A. Glaze
My Term Expires: 12-24-16

PLANNING COMMISSION CERTIFICATE

STATE OF KANSAS)
) SS
CITY OF WICHITA)

This plat of "WICHITA DESTINATION DEVELOPMENT" has been submitted to and approved by the Wichita-Sedgwick County Metropolitan Area Planning Commission, Wichita, Kansas.

Dated this 24 day of July, 2014

WICHITA-SEDGWICK COUNTY METROPOLITAN AREA PLANNING COMMISSION

Don Klausmeyer, Chairman
John L. Schlegel, Secretary



GOVERNING BODY CERTIFICATE

STATE OF KANSAS)
) SS
CITY OF WICHITA)

The dedications shown on this plat are hereby accepted and this plat is hereby approved by the governing body of the City of Wichita, Kansas.

Dated this 12 day of May, 2014

At the direction of the City Council;

Jeff Longwell, Mayor
Karen Sublett, City Clerk

TRANSFER RECORD

Entered on transfer record this 5th day of June, 2015

Kelly B. Arnold
County Clerk



REGISTER OF DEEDS CERTIFICATE

STATE OF KANSAS)
) SS
COUNTY OF SEDGWICK)

This is to certify that this instrument was filed for record in the Register of Deeds office this 5th day of June, 2015, at 9:02:37 o'clock A.M. and is duly recorded.

Bill Meek, Register of Deeds

Tonya E. Buckingham, Deputy

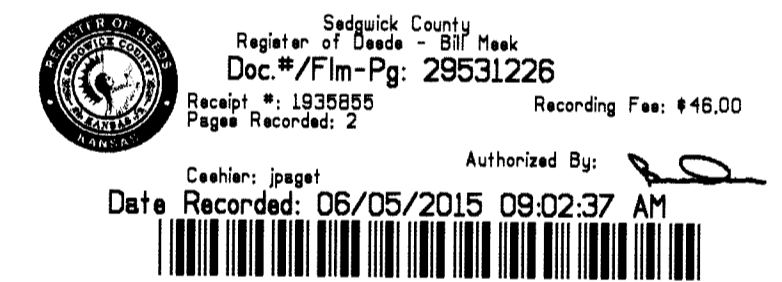

COUNTY SURVEYOR

Reviewed in accordance with K.S.A. 12-512b on this 5th day of June, 2015.

Tricia L. Robello, LS #1246
Deputy County Surveyor
Sedgwick County, Kansas

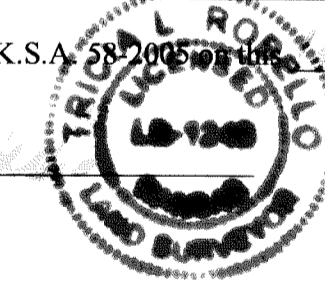

WICHITA DESTINATION DEVELOPMENT

Prepared For:
Wichita Destination Developers, Inc.
1707 N. Waterfront Parkway
Wichita, KS 67206
(316) 685-5341

Date of Preparation:
May 28, 2014



1138 W. CAMBRIDGE CIRCLE DRIVE
KANSAS CITY, KANSAS 66103
913.317.9500
WWW.RIC-CONSULT.COM

FINAL PLAT

WICHITA DESTINATION DEVELOPMENT

AN ADDITION TO WICHITA, SEDGWICK COUNTY, KANSAS

A REPLAT OF ALL OF K96 AND GREENWICH NORTH ADDITION

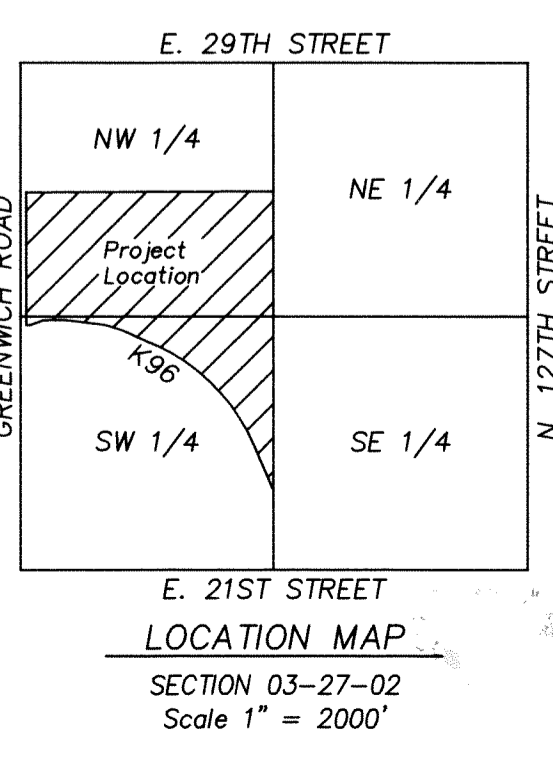
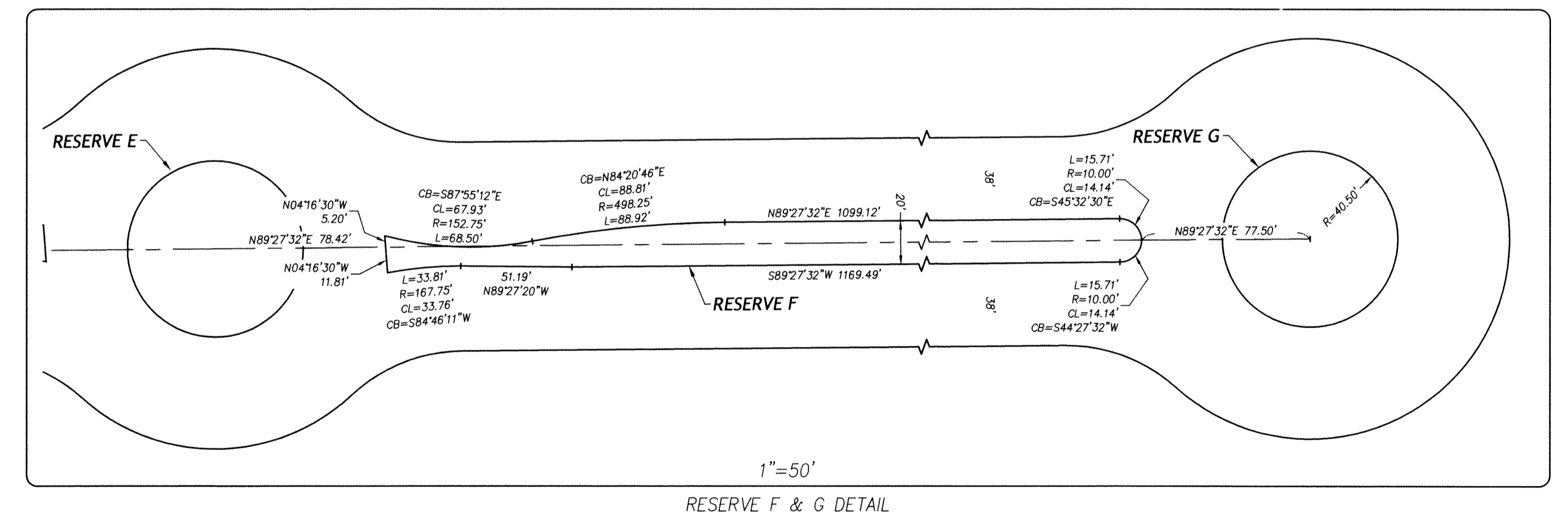
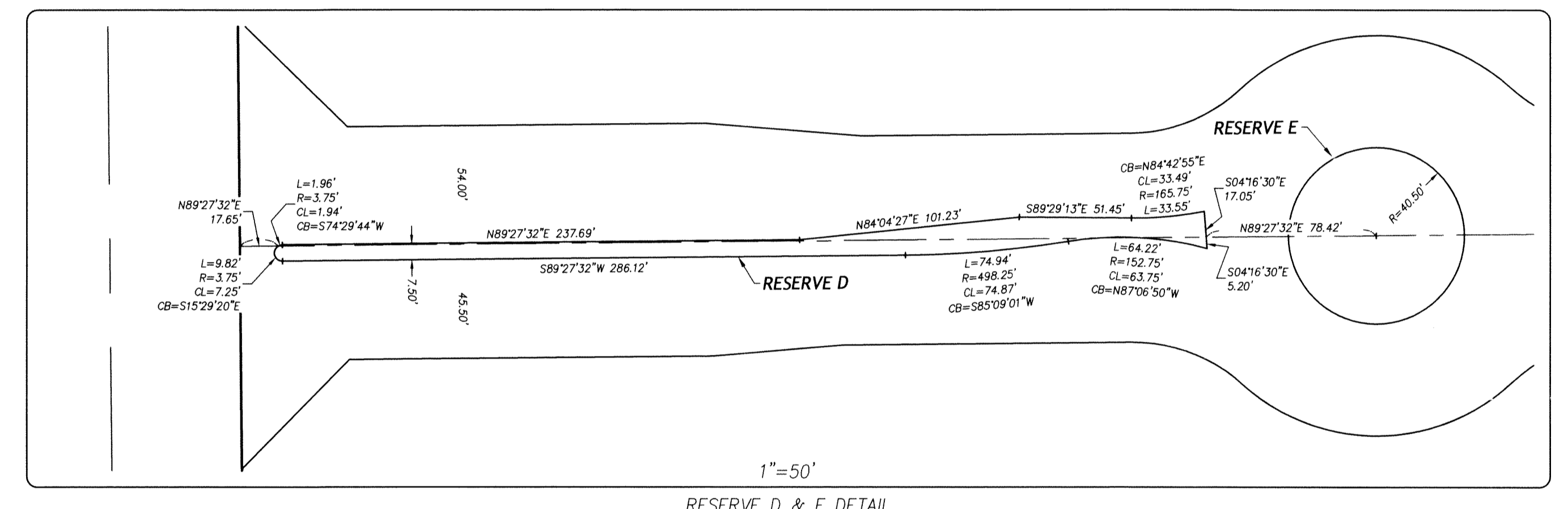
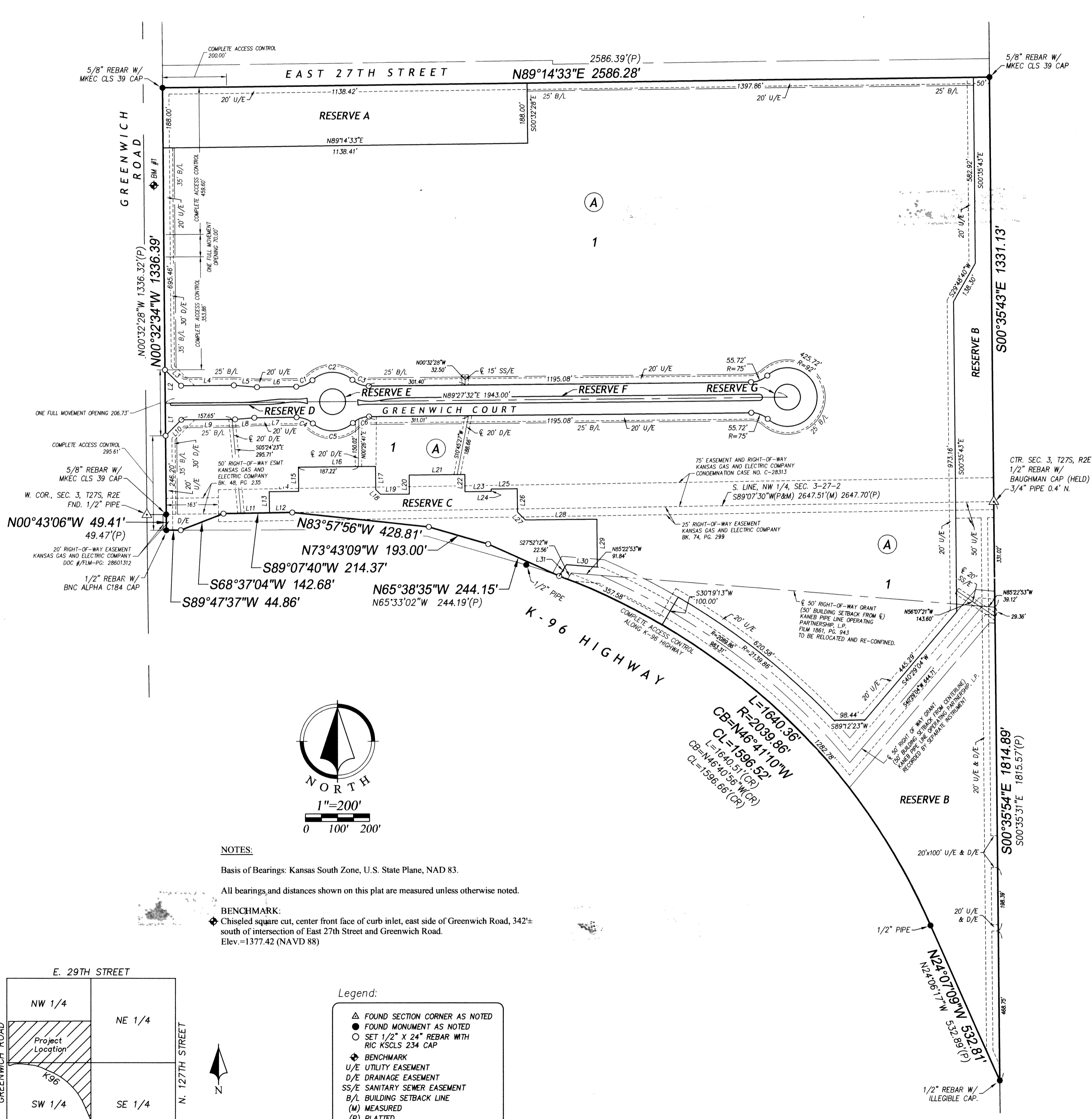

NOTES:

Basis of Bearings: Kansas South Zone, U.S. State Plane, NAD 83.

All bearings and distances shown on this plat are measured unless otherwise noted.

BENCHMARK:

Chiseled square cut, center front face of curb inlet, east side of Greenwich Road, 342± south of intersection of East 27th Street and Greenwich Road.
Elev.=1377.42 (NAVD 88)

- Legend:**
- ▲ FOUND SECTION CORNER AS NOTED
 - FOUND MONUMENT AS NOTED
 - SET 1/2" X 24" REBAR WITH RIC KSCLS 234 CAP
 - ◆ BENCHMARK
 - U/E UTILITY EASEMENT
 - D/E DRAINAGE EASEMENT
 - SS/E SANITARY SEWER EASEMENT
 - B/L BUILDING SETBACK LINE
 - (M) MEASURED
 - (P) PLATED
 - L LENGTH OF CURVE
 - R RADIUS OF CURVE
 - CL CHORD LENGTH
 - CB CHORD BEARING

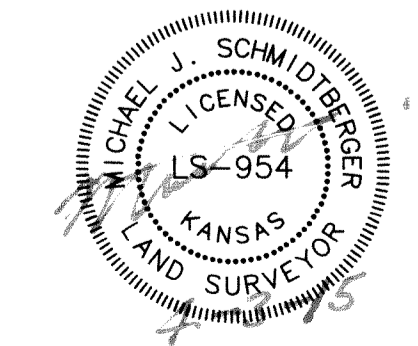

SHEET 1 OF 1

WICHITA DESTINATION DEVELOPMENT

Prepared For:
Wichita Destination Developers, Inc.
1707 N. Waterfront Parkway
Wichita, KS 67206
(316) 685-5341

Date of Preparation:
May 28, 2014

Renaissance Infrastructure Consulting
1138 W. Cambridge Circle Drive
Kansas City, Kansas 66103
913.317.9500
WWW.RIC-CONSULT.COM

GENERAL NOTES

- The Contractor shall comply with all applicable safety regulations. All construction shall be completed following current City Standard Specifications and Special Provisions.
- Contractor will be required to provide notice to utility companies a minimum of seventy-two (72) hours prior to any excavation, as follows:
 Kansas One-Call 316.687.2470
 The Contractor must notify the following in case of an emergency:
 AT&T 1.800.246.8464
 Black Hills Energy 1.800.694.8989
 City of Wichita Water 316.268.4555
 City of Wichita Sewer 316.268.4073
 City of Wichita Stormwater 316.268.4090
 City of Wichita Traffic 316.268.4034
 Cox Communication 1.888.249.3530
 Kansas Gas Service 1.888.482.4950
 Westar Energy 1.800.544.4857
- Utility service lines, poles, ect. are to be adjusted as necessary by others prior to construction unless the plans specifically call for their adjustment by the Contractor or unless the plans specifically identify a utility to be adjusted by its owner during construction. Existing utilities and their location, as shown on the plans, represent the best information obtainable for design. The Contractor will be required to work around existing utilities within the right-of-way which do not conflict with proposed construction.
- Rubble from the removal of miscellaneous structures and excess excavation which is to be wasted shall be disposed of on sites to be provided by the Contractor. These sites shall be approved by the Engineer as to suitability, appearance and the site location. Locations, in the opinion of the Engineer, that will leave an unsightly appearance will not be approved. All disposable sites must be approved by the Kansas Department of Health and Environment. Material either stockpiled or disposed of in a flood plain would require a Kansas State Board of Agriculture permit. Any material buried or stockpiled beyond approved construction limits would require an additional archeological investigation unless buried in a previously approved borrow location.
- Trees and shrubs in public right-of-way which are in direct conflict with proposed new construction shall be removed by the Contractor with the Engineer's approval. Trees and shrubs which are not in direct conflict with proposed new construction shall be saved and protected from damage.
- The Contractor shall give all property owners and / or tenants of developed property abutting the construction of this project a minimum of ten (10) days notice prior to the start of construction.
- The Contractor shall be responsible for preserving property irons. The Contractor will be required to re-established any property irons which are damage or destroyed by his construction operations. Such irons shall be re-established by a licensed land surveyor in accordance with state laws.
- The Water Distribution Division shall field locate valves one time during construction when requested by the Contractor. It shall be the Contractor's responsibility to preserve such field locations during the construction process. Water valves, valve boxes or fire hydrants damaged during construction shall be repaired by the Contractor at their own expense. Valve boxes and water meters within the project limits shall be adjusted to match field grades.
- The Contractor shall notify the consultant engineer and Tom Mason with the City at 316.268.4574 with the anticipated construction start date and notify them of project completion. Staking and inspection for this project will be the responsibility of the Contractor.
- If traffic is impacted by construction, a traffic control plan must be submitted and approved by the City Traffic Engineer, Brian Coon at traffic@wichita.gov before construction can begin. The Contractor shall be responsible for all traffic control measures to facilitate construction. All construction zone markings and signage shall conform to the latest version of the Manual on Uniform Traffic Control Devices (MUTCD) as published by the US Department of Transportation, Federal Highway Administration. All cost associated with construction markings and signage shall be the Contractors responsibility.
- All areas disturbed during construction that will not be under proposed pavement shall be restored to match existing conditions.
- Opening and Closing of Water Valves Shall be Done Slowly to Prevent Damage to the Water Distribution System for Water Hammer. All Valves Closed by the Contractor must be Reopened as New Construction Permits. The Project Inspector must Ascertain that any Valve Closed by the Contractor is Reopened. The Contractor will be Permitted to Operate Water Valves only when the Project Inspector Assigned to the Project is Present.
- The Contractor shall lay a Tracer Wire and Set Test Stations along all Water Pipe Installed in Accordance with City Specifications and Tracer Wire Detail on Detail Sheet WL-101, Cost is Subsidiary to Pipe Installation.
- The Contractor shall Provide Materials for Temporary Blowoff of Waterlines. Connection to the Existing Waterline(s) shall be made with Clean, Swabbed Pipe and Flushed upon Completion of Tie-Ins.
- Requests for Short Term Water Interruptions shall be made to the City Water Distribution Division and will be Subject to their Approval. The Contractor shall give Written Notice to any Property Owner, Business, and/or Tenants that will have Water Service Interrupted at Least 5 days in Advance. Such Notification Should Indicate the Time and Date that the Water will be Turned Off and When their Service will be Restored. No Business, Property Owner, and/or Tenants shall be without Water Service for more than 8 hours. Proposed Tie In Locations which will Affect Water Service to Property Owners shall be performed During non-peak hours.
- The Contractor must Schedule the Connections to the Existing Main with the City such that there is a Minimum Disruption of Service. Connections shall be made during Periods of Low Water Usage. The Contractor shall submit his Proposal Schedule for Completing Work for City Approval at Least 10 Days Prior to Beginning Construction.
- Deflections at Pipe Joint or Couplings shall not exceed the Pipe Manufactures Recommended Maximum. Where Deflections are Greater than the Maximum Allowed, the Contractor shall utilize CI MJ Long Sleeve or Multiple Joints.
- Any Extension Greater than one Length of Pipe shall Require Testing.
- Any Existing Joint Exposed During Excavation shall be Replaced if within Four Feet of Proposed Joint.
- City Maintenance of Water Mains Ends at Right-of-Way or Easement Line.
- Valves 12 inch and Larger are to be Operated by the City Water Distribution Division, 48 Hours of Advance Notice is Required.
- All Wet Taps shall be Installed by the City of Wichita. The Contractor will Reimburse the City for Tapping Gates.
- The Contractor shall Protect from Damage and Support Existing Utilities through Construction as Approved by the Utility Owner and the Engineer at the Contractors Expense
- Contractor shall Limit the Extent of Trench Openings Overnight and Weekends to Less than 50 Feet.
- Any Sidewalk, Drive Approach, Curb, or Street Pavement Removal to Construct Project must have a Pavement Cut Permit and be Replaced by the City Contractor. Permits can be Obtained by Calling 316.268.4501
- The Basis of Bearing for this site is Kansas South Zone, U.S. State Plane, NAD 83.

SUMMARY OF QUANTITIES

No.	Description	Quantity	Unit	As-Built
1	8" PVC	748.57	LF	
2	8" DI CL	26.00	LF	
3	6" DI CL	4	LF	
4	8" Gate Valve	5	EA	
5	6" Gate Valve	1	EA	
6	8" Tapping Sleeve	5	EA	
7	Connect to Existing Waterline	5	EA	
8	Vault & Backflow Preventer	1	EA	
9	Fire Hydrant	1	EA	
10	8"x6" Reducer	1	EA	

Quantities are for Information Only. Contractors to Verify All Quantities Prior to Construction.

Thrust Blocks are Considered Subsidiary to Other Items.

PROJECT BENCHMARK

Chiseled square cut, center front face of inlet East side of Greenwich Road, 342 feet +/- South of the intersection of East 27th Street and Greenwich Road
 Project Elevation = 1377.42
 KDOT Elevation = 1378.05
 (Project Elevation is -0.63 feet from KDOT)

BENCHMARKS:

TBM 1:
 Chiseled Square cut on E. Curb of island in center of Greenwich Road.
 Approximately 60' S. of intersection of westbound ramp to K-96.
 RIC Project Datum Elev. = 1373.08

TBM 2:
 Chiseled Square cut on south curb of 27th Street approximately 690 feet east of intersection of Greenwich Road.
 RIC Project Datum Elev. = 1378.40

TBM 3:
 Chiseled Square cut on south side of 27th Street approximately 330 feet east of intersection of Greenwich Road.
 RIC Project Datum Elev. = 1378.36

PRIVATE PROJECT WATER LINE
 15-0196
 WICHITA DESTINATION DEVELOPMENT-PHASE 6
 LOT 1, K-96 GREENWICH ADDITION

GENERAL NOTES AND
 QUANTITIES

NO.	BY	DATE	REVISION
3.	JWD	MES 3/10/16	AS PER CITY COMMENTS
2.	JWD	MES 13/09/16	AS PER CITY COMMENTS
1.	JWD	MES 3/02/16	AS PER CITY COMMENTS
			ORIGINAL SUBMITTAL

Renaissance Infrastructure Consulting
 913.317.9500
 1138 W. CAMBRIDGE CIRCLE DRIVE
 KANSAS CITY, KANSAS 66103
 WWW.RIC-CONSULT.COM

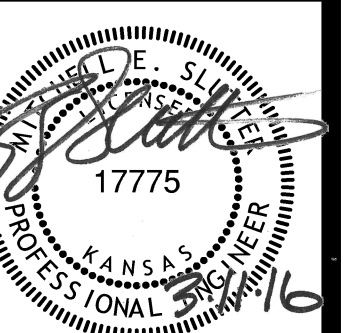

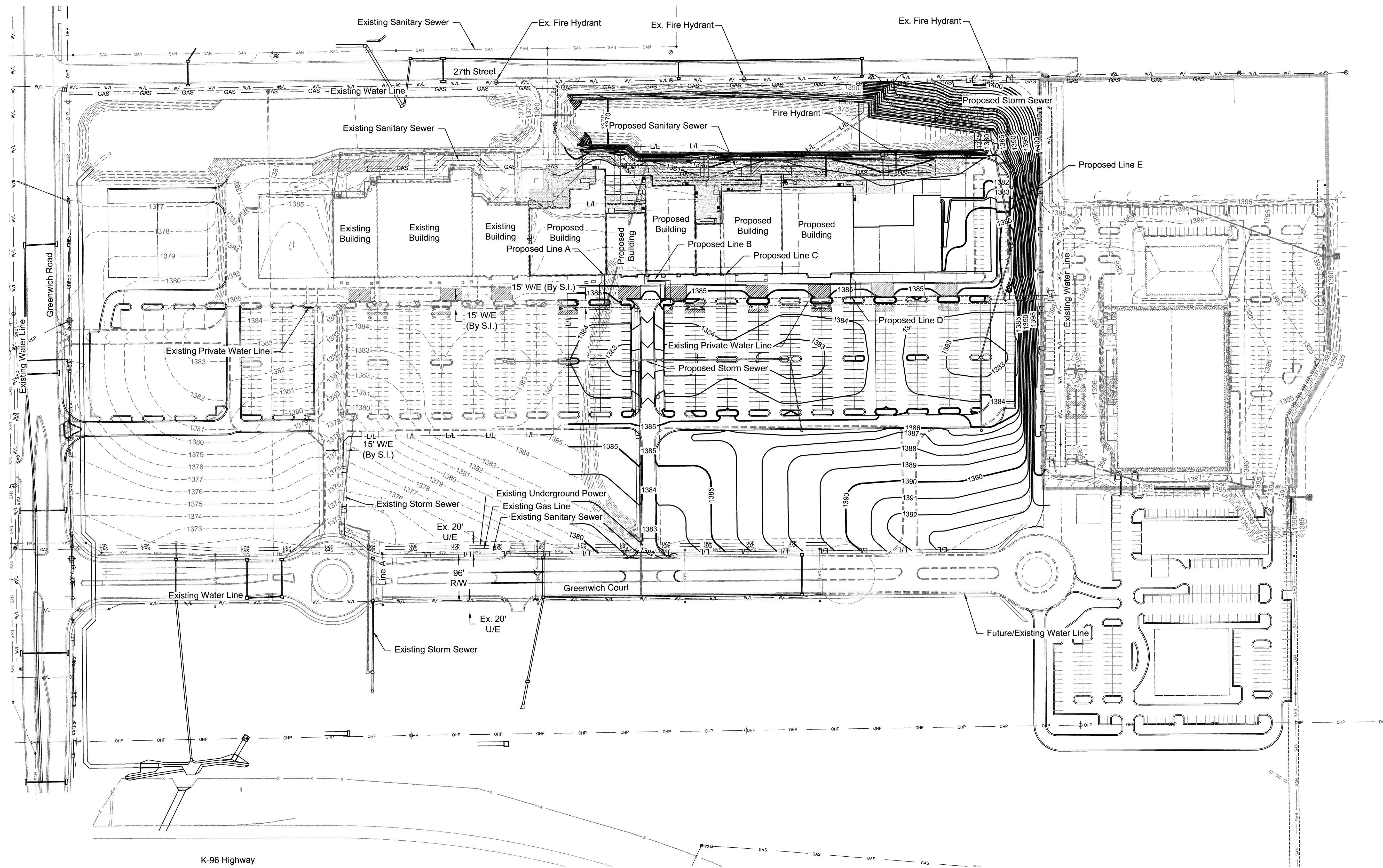

PROJECT BENCHMARK

Chiseled square cut, center front face of inlet East side of Greenwich Road,
342 feet +/- South of the intersection of East 27th Street and Greenwich Road
Project Elevation = 1377.42
KDOT Elevation = 1378.05
(Project Elevation is -0.63 feet from KDOT)

BENCHMARKS:

- TBM 1:
Chiseled Square cut on E. Curb of island in center of Greenwich Road.
Approximately 60' S. of intersection of westbound ramp to K-96.
RIC Project Datum Elev. = 1373.08
- TBM 2:
Chiseled Square cut on south curb of 27th Street approximately 690 feet east
of intersection of Greenwich Road.
RIC Project Datum Elev. = 1378.40
- TBM 3:
Chiseled Square cut on south side of 27th Street approximately 330 feet east
of intersection of Greenwich Road.
RIC Project Datum Elev. = 1378.36

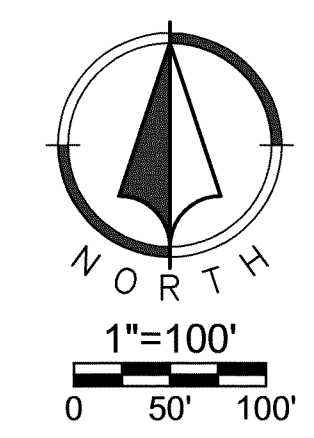

NO.	BY	DATE	REVISION
3.	JMO	MES 3/10/16	AS PER CITY COMMENTS
2.	JMO	MES 13/09/16	AS PER CITY COMMENTS
1.	JMO	MES 3/02/16	AS PER CITY COMMENTS
			ORIGINAL SUBMITTAL

Renaissance Infrastructure Consulting
913.37.9500
1138 W. CAMBRIDGE CIRCLE DRIVE
KANSAS CITY, KANSAS 64103
WWW.RIC-CONSULT.COM

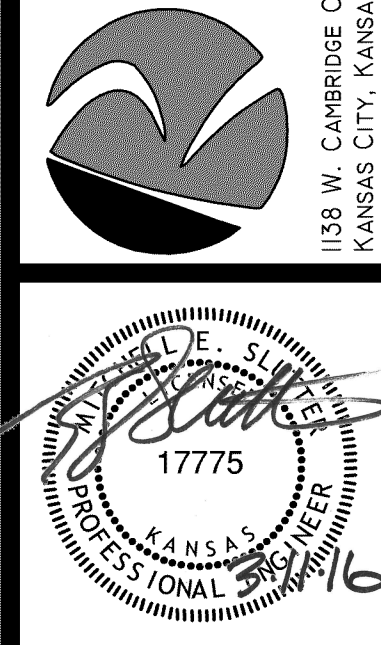

Mar 10, 2016-12:54pm
 Z:\RIC Design\2015\15-0196 Wichita K96 Strip Center I\Drawg15-0196 PRV-Building Connections.dwg

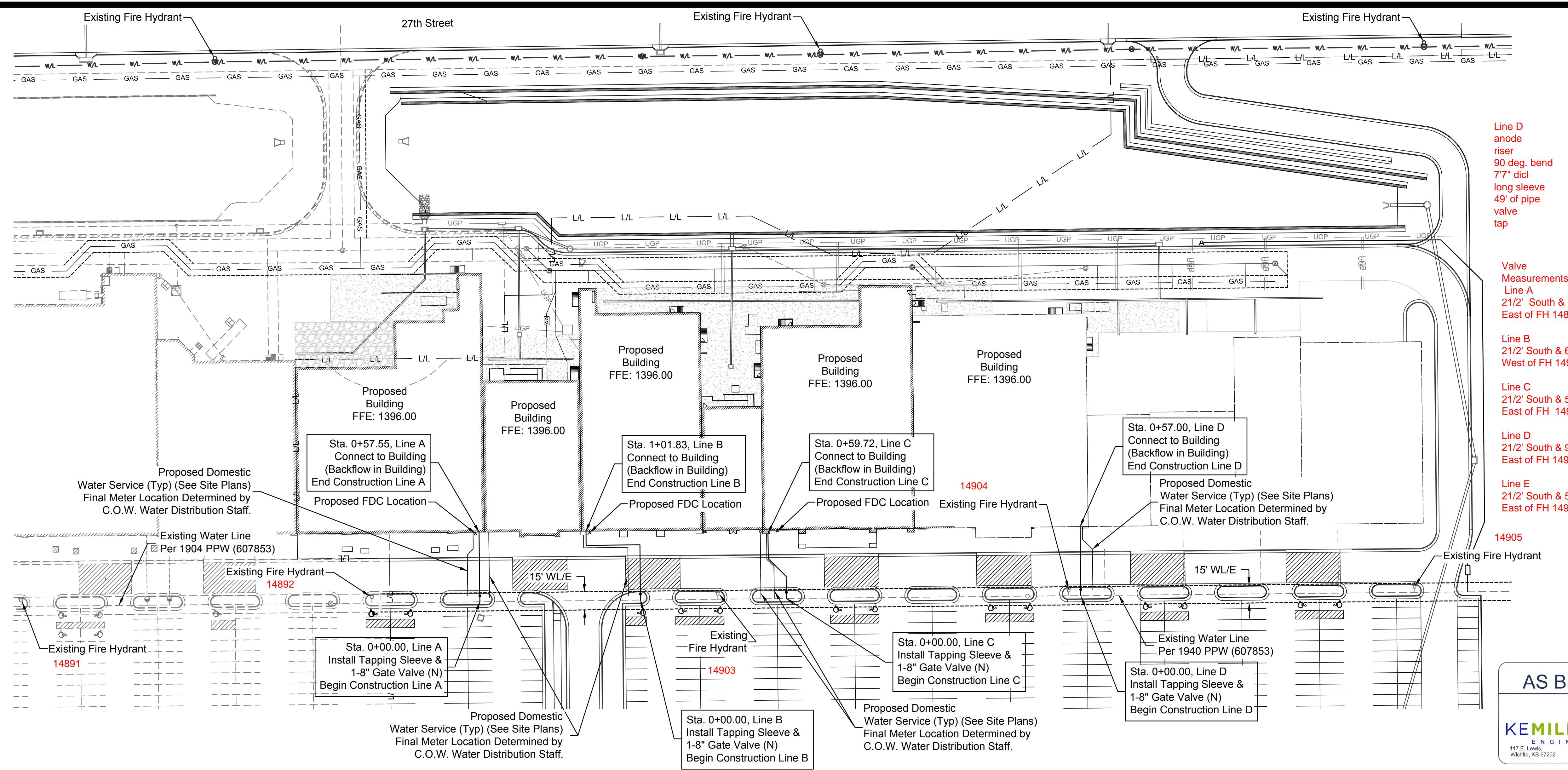

Line A
anode on riser
90 deg. bend to
riser
57.0' of pvc
valve and tap

Line B
anode ON RISER
8" DICL
LONG SLEEVE
4' PVC
90 DEG. BEND
40' PVC
90 DEG. BEND
45' PVC
8" VALVE
TAP

Line C
anode
riser
90 deg. bend
megalong
7'9" dicl
long sleeve
15'9" of pipe
45 deg. bend
18" of pipe
45 deg. bend
19'2" of pipe
valve

Line D
anode
riser
90 deg. bend
7'7" dicl
long sleeve
49' of pipe
valve
tap

Valve
Measurements
Line A
21/2" South & 90'
East of FH 14892

Line B
21/2" South & 66'
West of FH 14903

Line C
21/2" South & 55'
East of FH 14903

Line D
21/2" South & 9'
East of FH 14904

Line E
21/2" South & 51'
East of FH 14905

NOTE:
All taps will be completed by the City of
Wichita. The contractor shall reimburse
the City for said work. The contractor
shall set valve box to final grade.

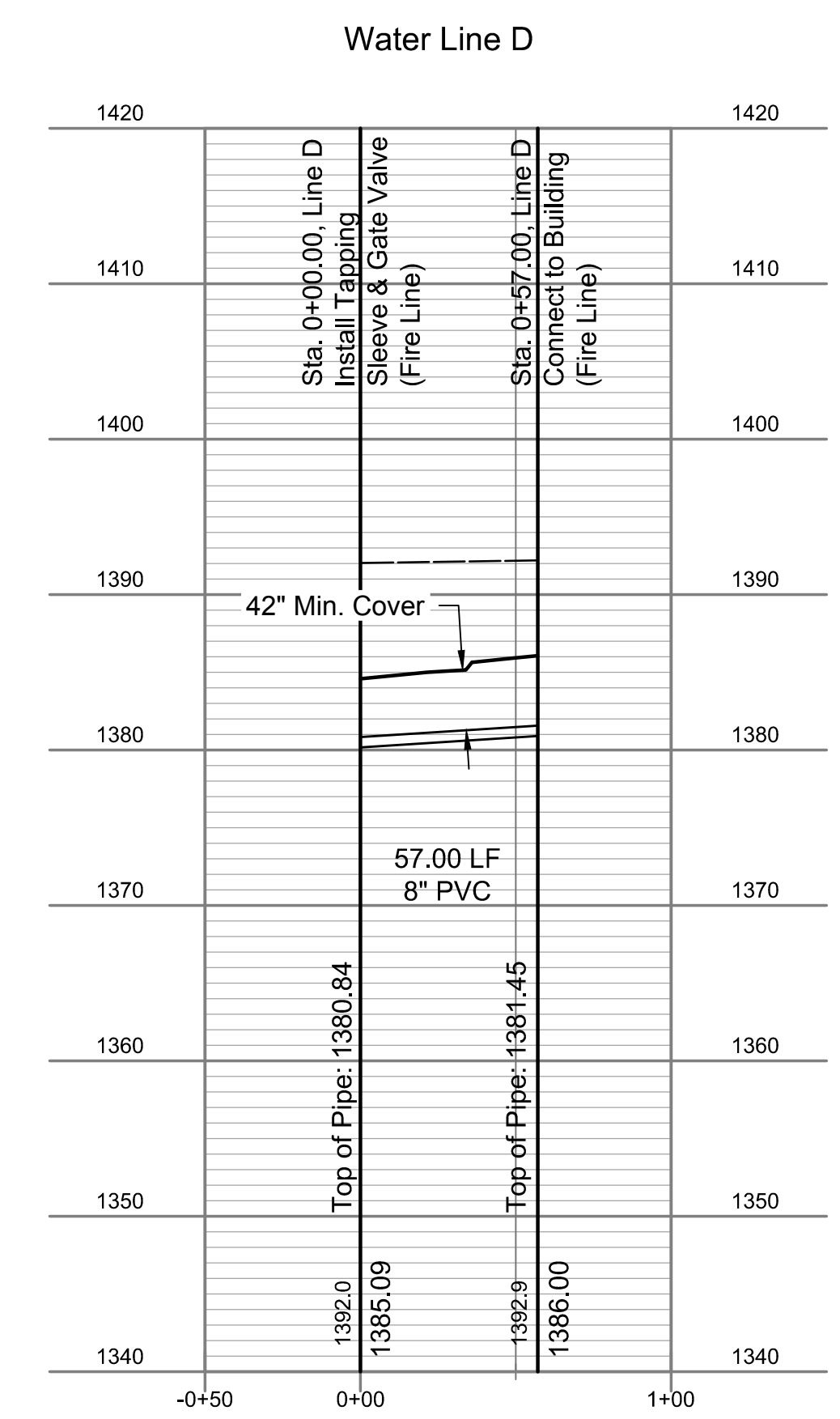
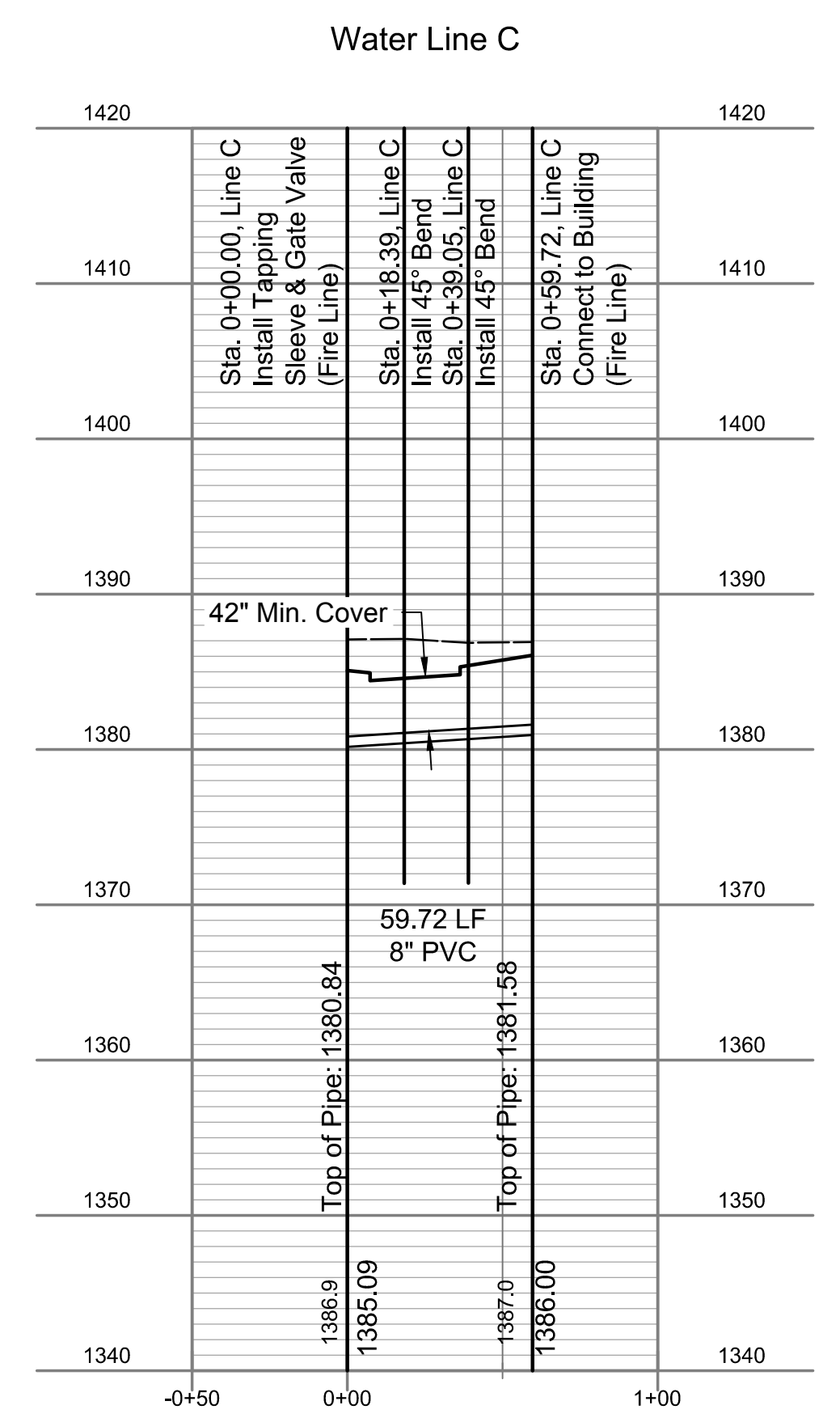
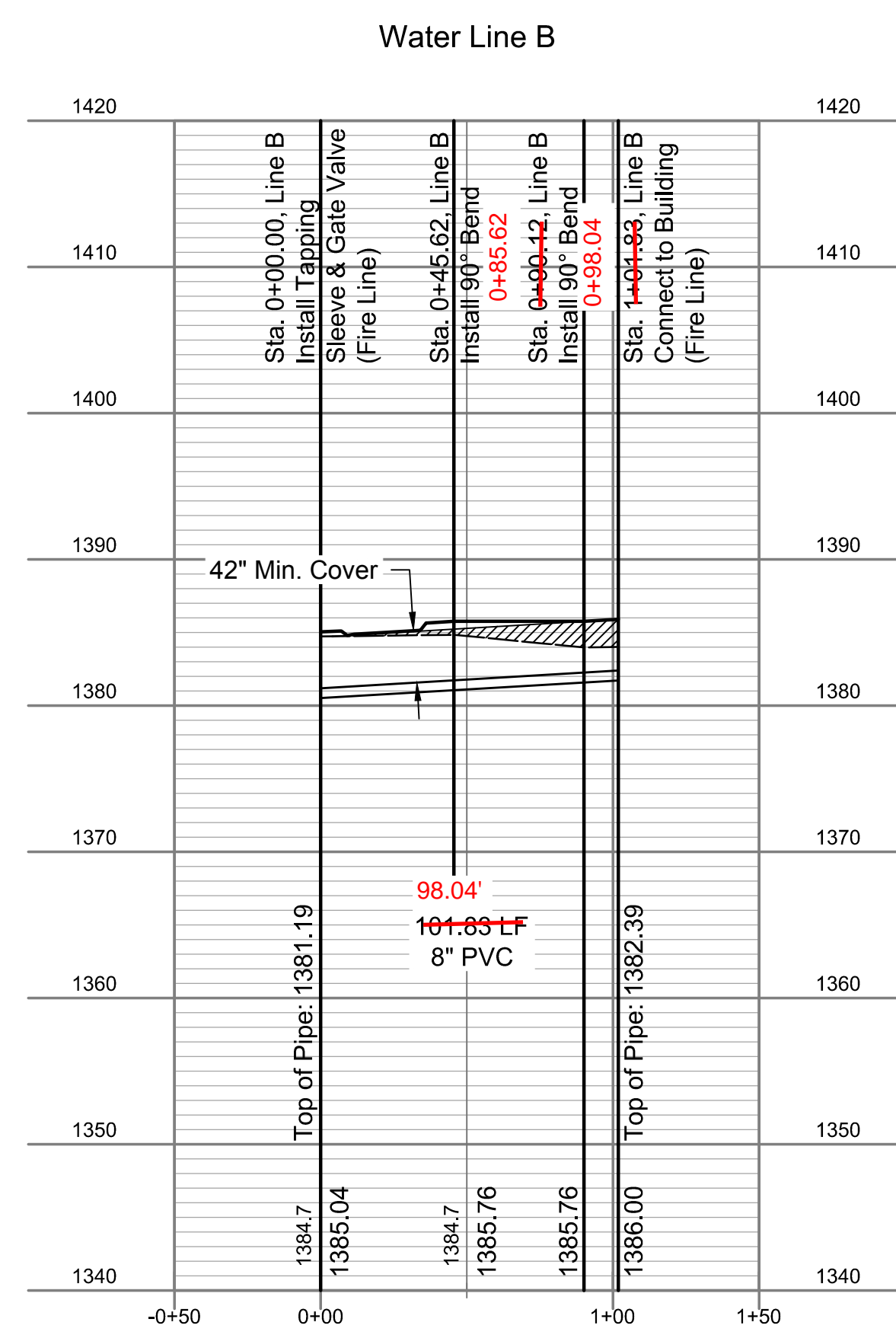
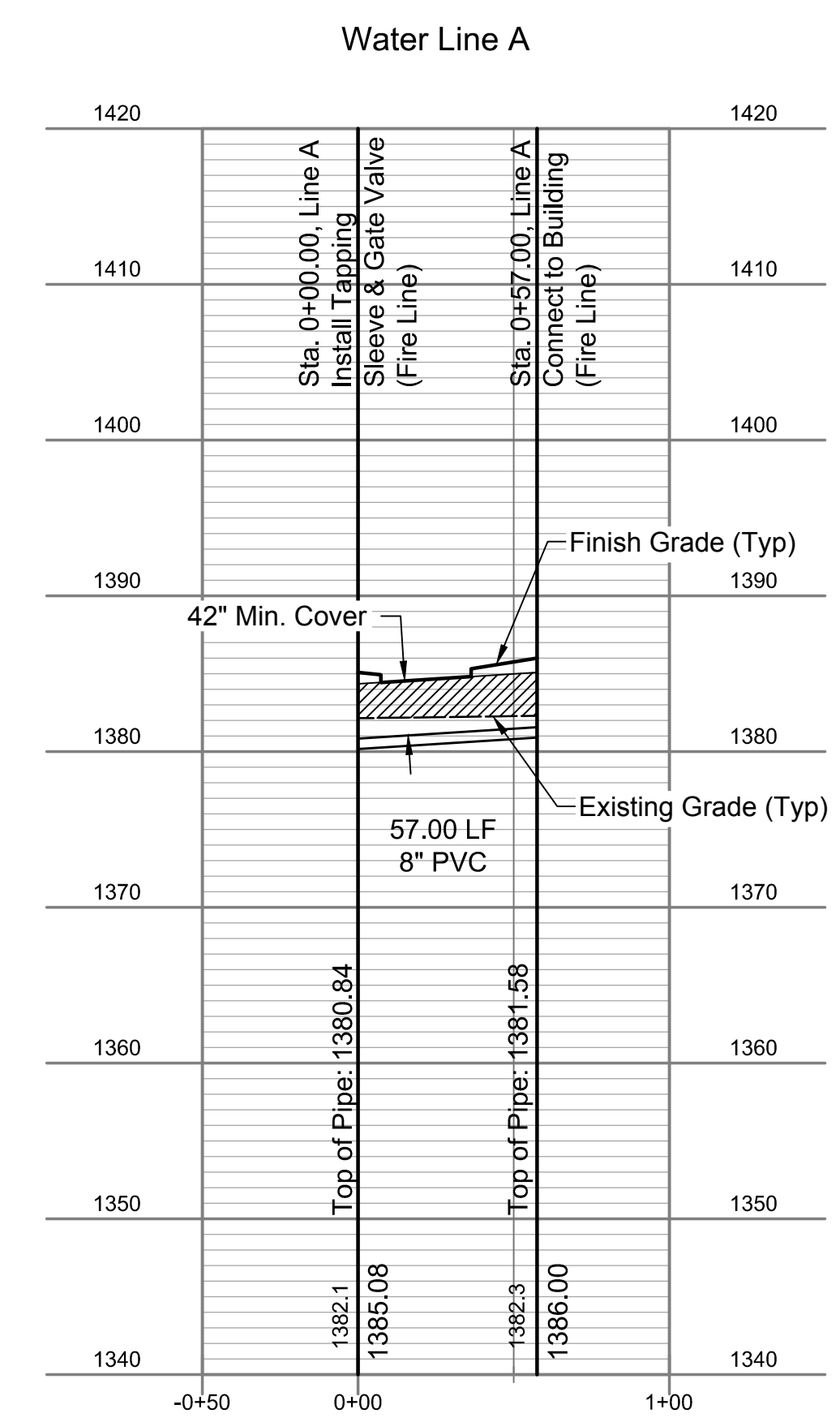
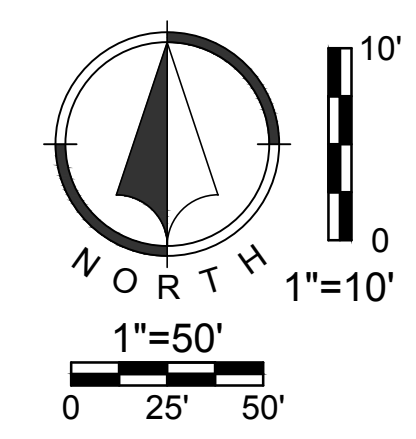
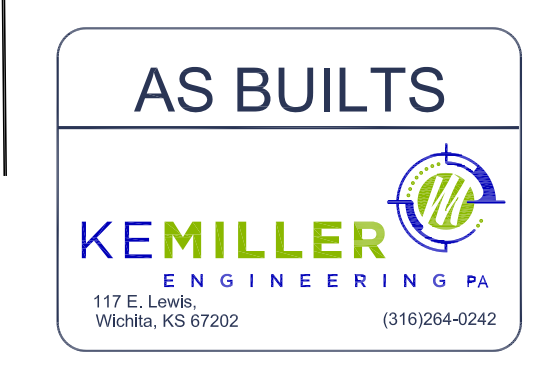

NO.	BY	DATE	REVISION
4.	JWD	MES 3/16/16	PER SITE CHANGES
3.	JWD	MES 3/10/16	AS PER CITY COMMENTS
2.	JWD	MES 3/09/16	AS PER CITY COMMENTS
1.	JWD	MES 3/02/16	AS PER CITY COMMENTS
	JWD	MES 2/11/16	ORIGINAL SUBMITTAL

Renaissance Infrastructure Consulting
1138 W. Cambridge Circle, Drive
Kansas City, Kansas 66103
913.317.9500
www.RIC-CONSULT.COM

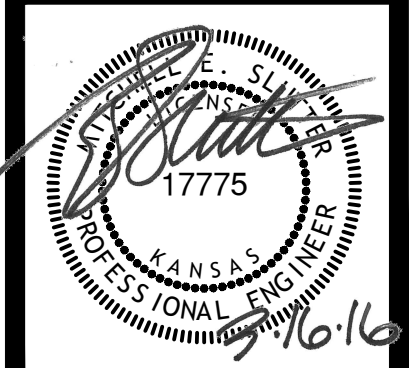

Mar 21, 2016 2:59pm
Z:\R\C\Design\2015\15-0196 Wichita K96 Strip Center I\DWG\15-0196 PPV-Building Connections.dwg

NO.	BY	DATE	REVISION
4.	JWD	MES 3/16/16	PER SITE CHANGES
3.	JWD	MES 3/10/16	AS PER CITY COMMENTS
2.	JWD	MES 3/09/16	AS PER CITY COMMENTS
1.	JWD	MES 3/02/16	AS PER CITY COMMENTS
	JWD	MES 2/11/16	ORIGINAL SUBMITTAL

Renaissance Infrastructure Consulting
 1138 W. CARROLLWOOD DRIVE
 KANSAS CITY, KANSAS 66103
 913.372.9500
 WWW.RIC-CONSULT.COM



- EXISTING WATER LINE
- TAPPING SLEEVE
- 8" VALVE
- MEGALUG
- 4'9" 8" DICL
- MEGALUG
- 45 DEG. BEND (VERT.)
- MEGALUG
- 33" DICL
- MEGALUG
- 45 DEG. BEND (VERT.)
- MEGALUG
- 5' OF DICL INTO VAULT
- MEGALUG
- VAULT
- 5' OF DICL
- MEGALUG
- 221/2 DEG. BEND(HORZ.)
- 24' OF 8" PVC
- 221/2 DEG. BEND (HORZ.)
- 198.96' OF PVC
- 45 DEG. BEND (HORZ.)
- 48.12' OF PVC
- 45 DEG. BEND (HORZ.)

AS BUILTS

KEMILLER ENGINEERING PA
 117 E. Lewis,
 Wichita, KS 67202 (316)264-0242

NOTE:
 All taps will be completed by the City of Wichita. The contractor shall reimburse the City for said work. The contractor shall set valve box to final grade.

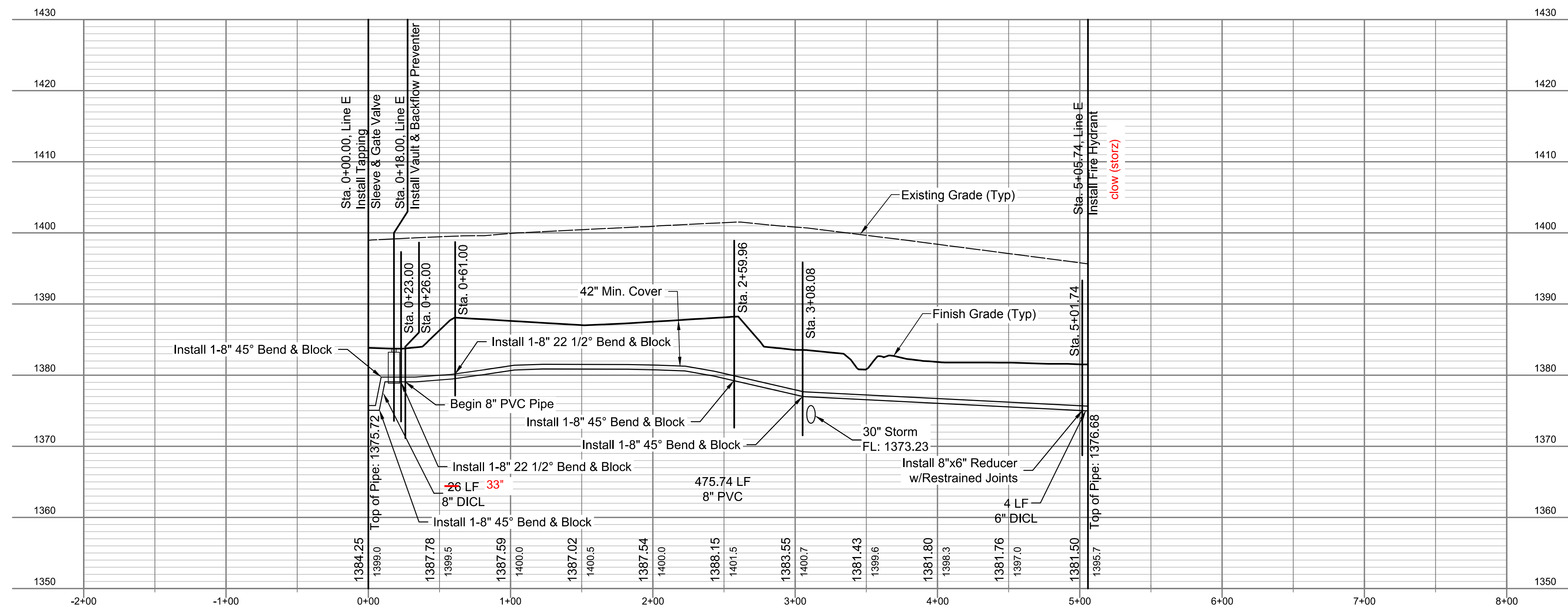
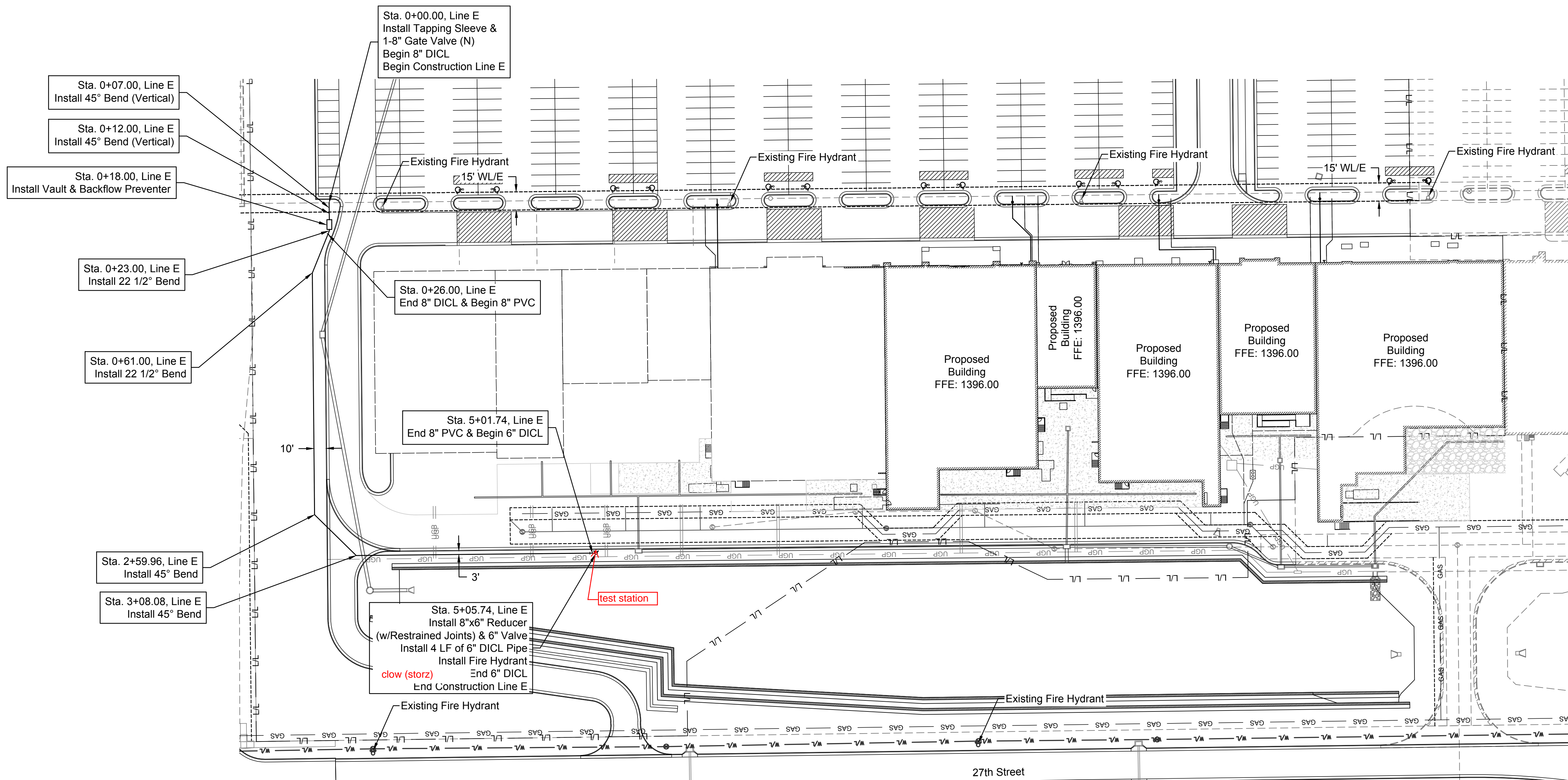
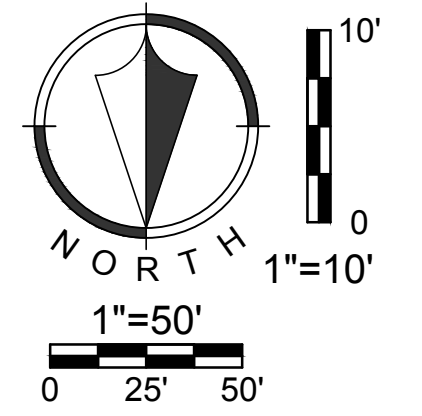

Mar 21, 2016 2:59pm
 Z:\R\C Design\2015\15-0196 Wichita K96 Strip Center ILL\DWG\15-0196 PPV-Building Connections.dwg

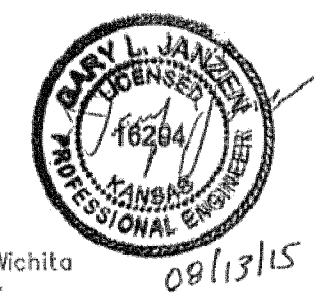
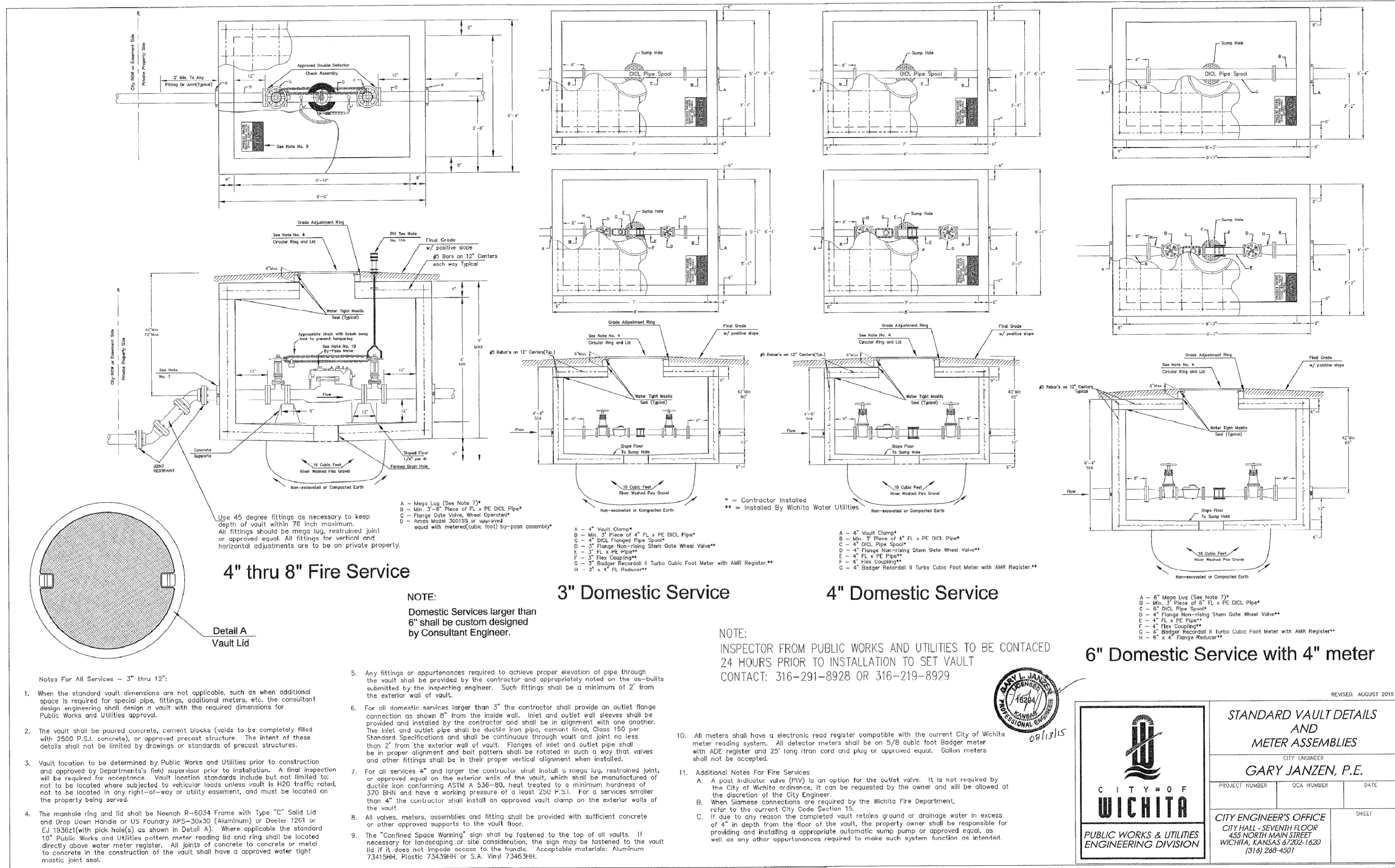

REVISÉ: AUGUST 2015

STANDARD VAULT DETAILS AND METER ASSEMBLIES

CITY ENGINEER
GARY JANZEN, P.E.

PROJECT NUMBER	OCA NUMBER	DATE

CITY ENGINEER'S OFFICE
CITY HALL - SEVENTH FLOOR
455 NORTH MAIN STREET
WICHITA, KANSAS 67202-1620
(316) 268-4501

SHEET

NO.	BY	DATE	REVISION
3.	JWO	MES 3/10/16	AS PER CITY COMMENTS
2.	JWO	MES 13/09/16	AS PER CITY COMMENTS
1.	JWO	MES 3/02/16	AS PER CITY COMMENTS
			ORIGINAL SUBMITTAL

Renaissance Infrastructure Consulting

913.317.9500
WWW.RIC-CONSULT.COM

1138 W. CARBIDE CIRCLE DRIVE
KANSAS CITY, KANSAS 64103

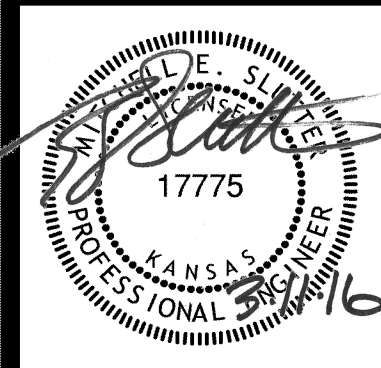

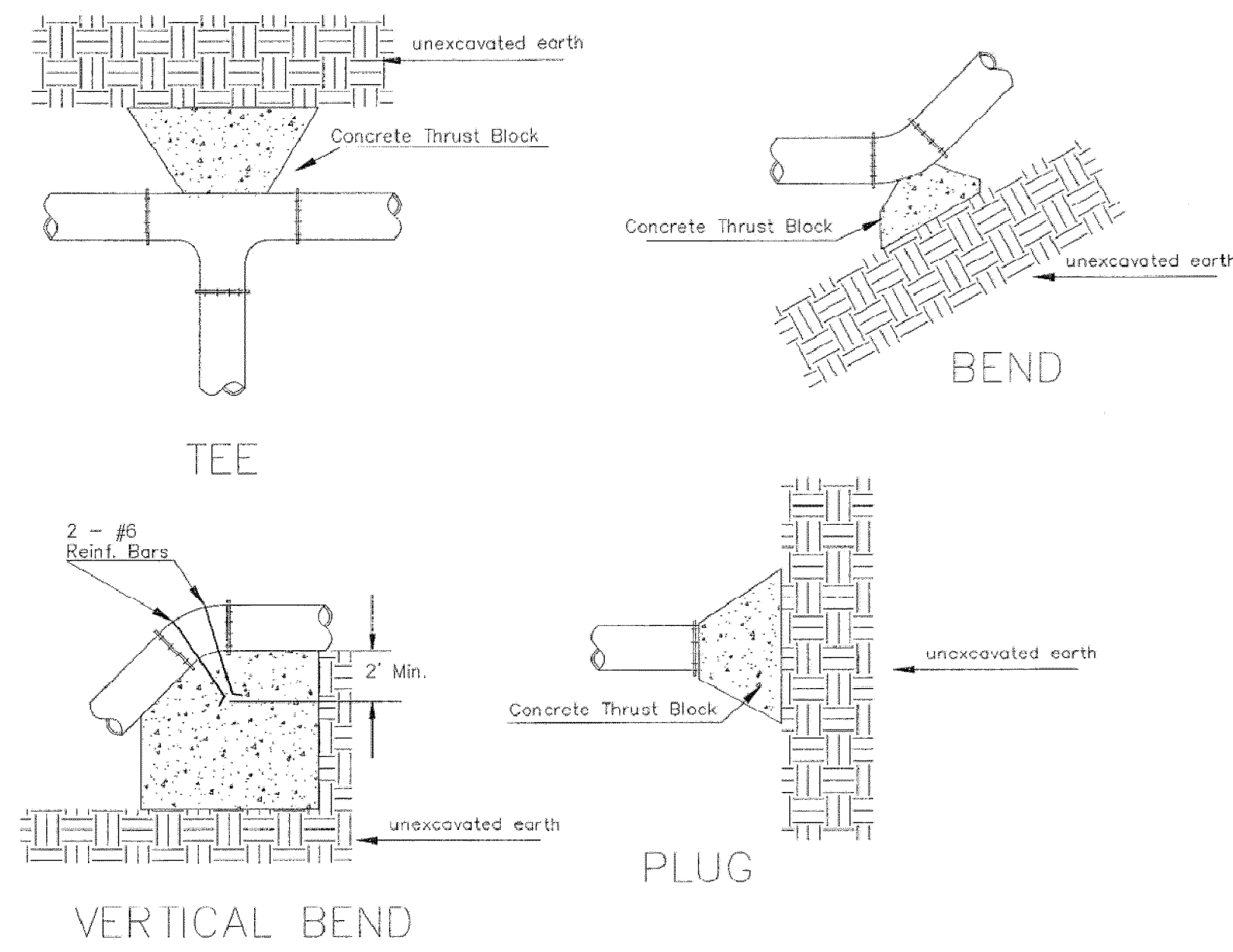

PIPE SIZE	THRUST AT FITTINGS IN TONS--AT 150#/IN ² P					
	PLUG	90°	45°	22 1/2°	11 1/4°	TEE
6"	2.8	3.95	2.15	1.09	.55	2.8
8"	4.9	6.95	3.75	1.90	.96	4.9
12"	11.4	16.1	8.75	4.45	2.25	11.4
16"	20.15	28.5	15.4	7.85	3.95	20.15
20"	31.15	44.0	23.85	12.15	6.10	31.15
24"	44.55	63.0	34.1	17.4	8.75	44.55

TYPICAL THRUST BLOCKS

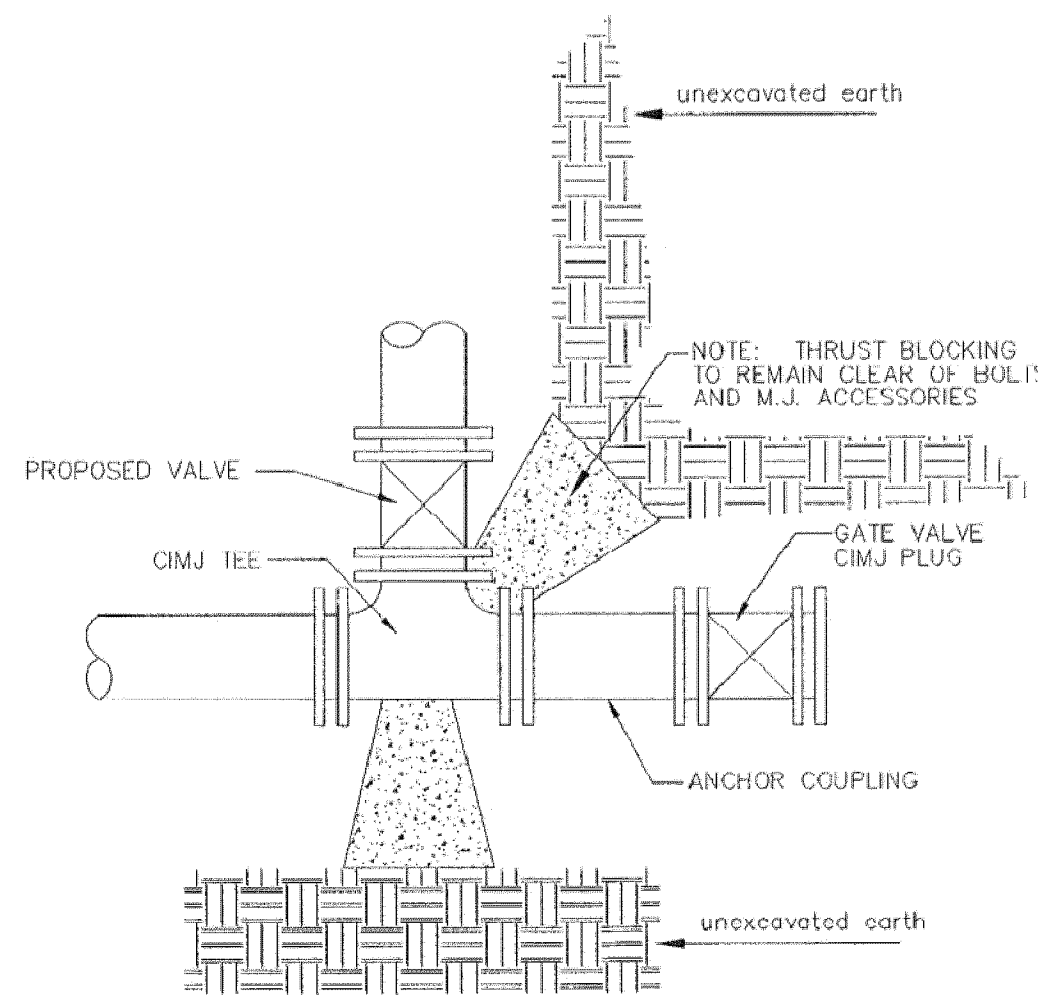

* PLANS GOVERN
UNLESS OTHERWISE NOTED ON PLANS

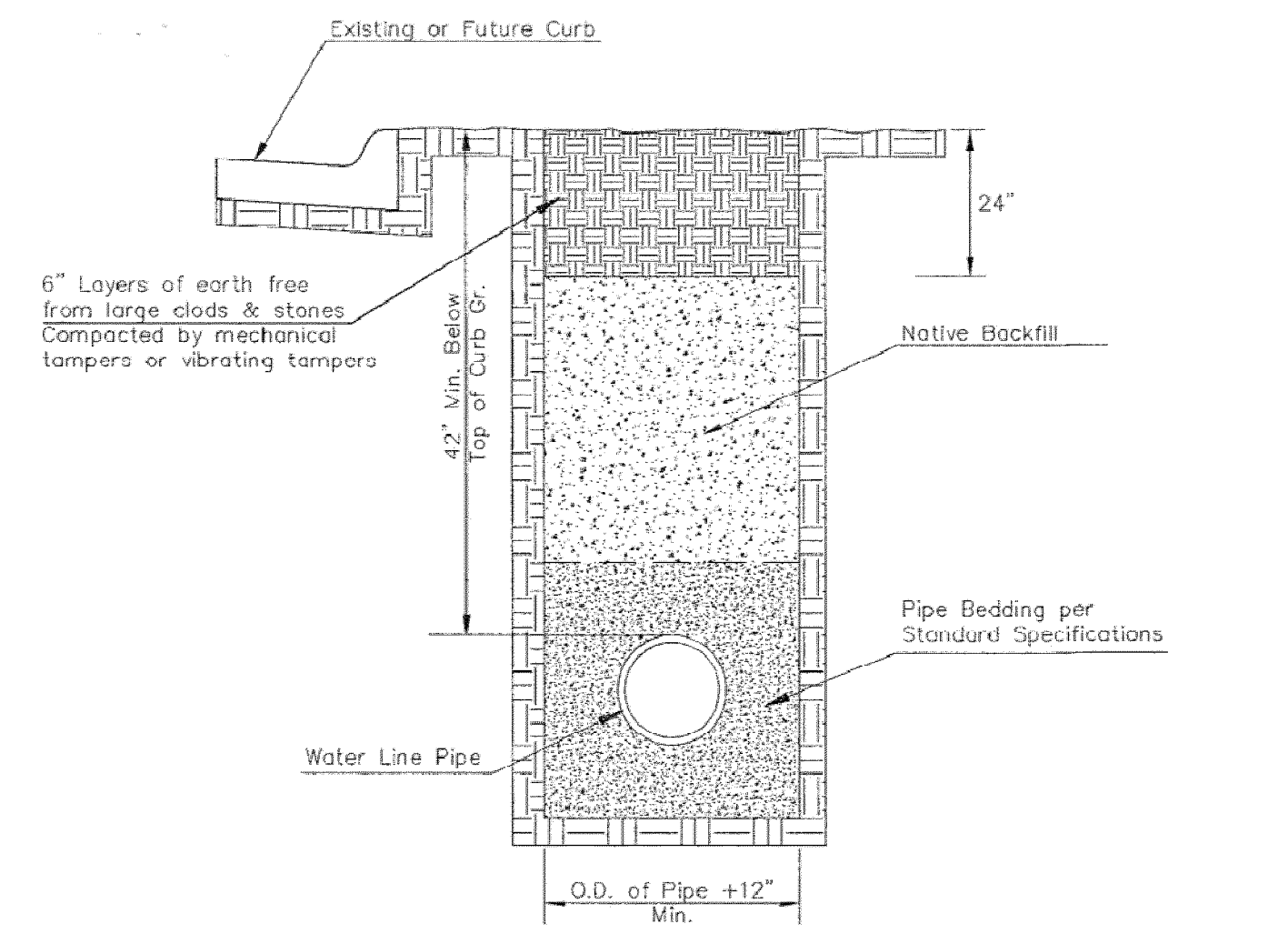

TRENCH COMPACTION IN ROAD RIGHT-OF-WAY

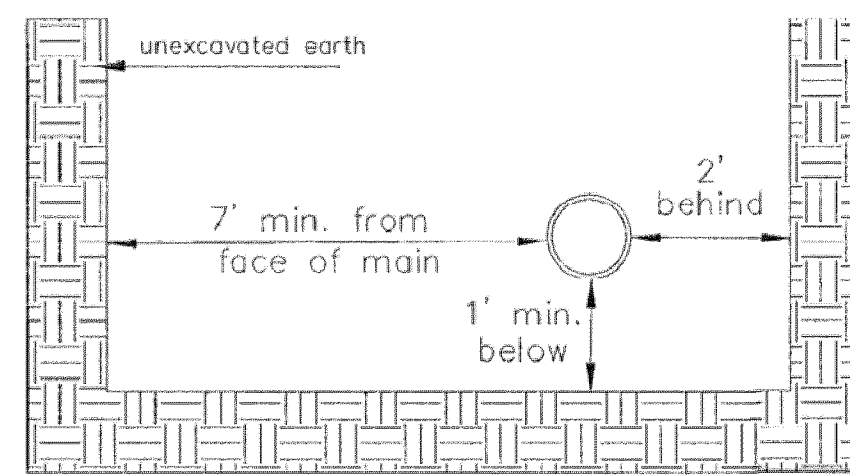

Note: When shoring is required it is to be per The City of Wichita Standard Specifications.

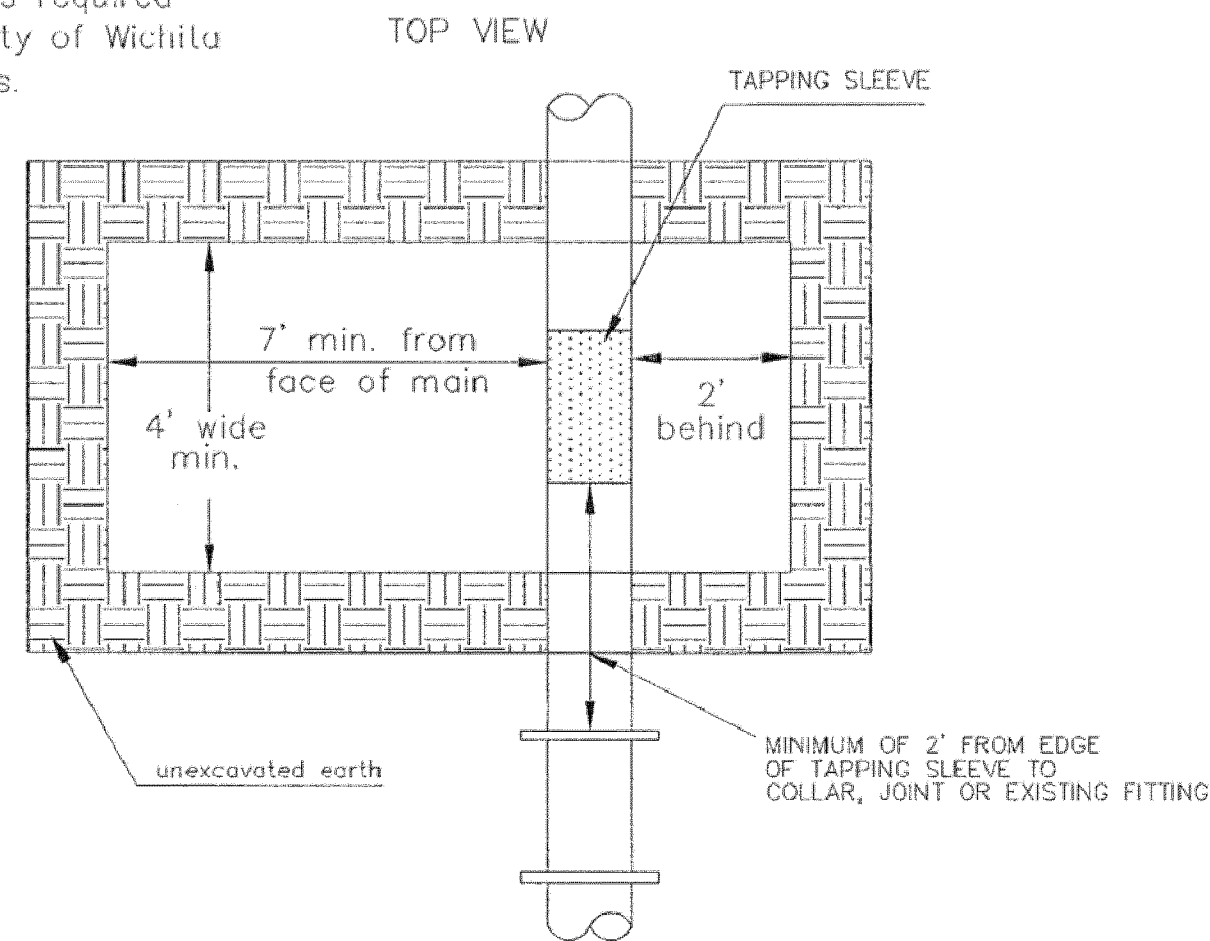

EXCAVATION FOR WET TAP

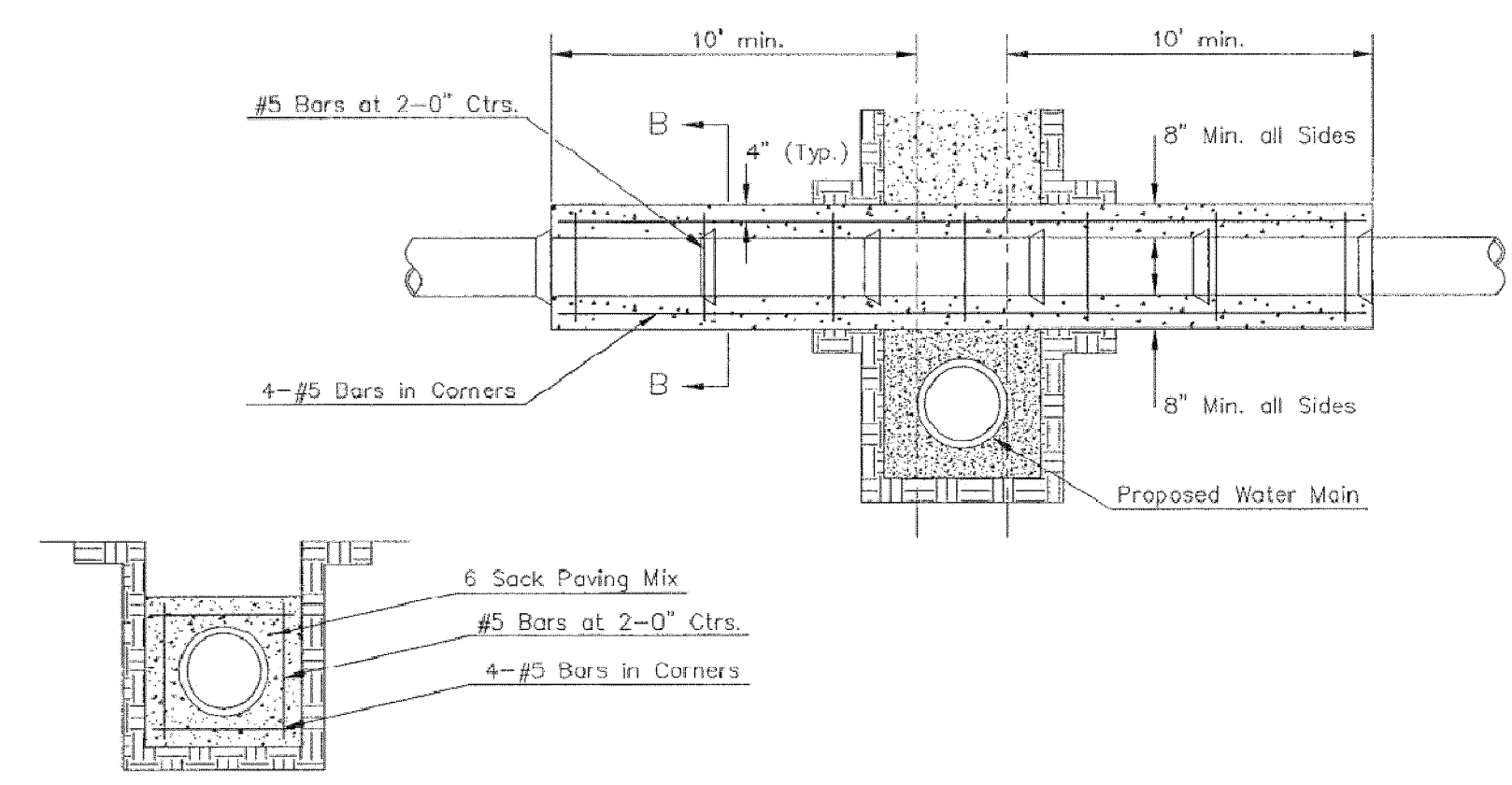

Note: Encasement to begin and end at a Bell on Sanitary Sewer Pipe.

REINFORCED CONCRETE ENCASEMENT OF SANITARY SEWER

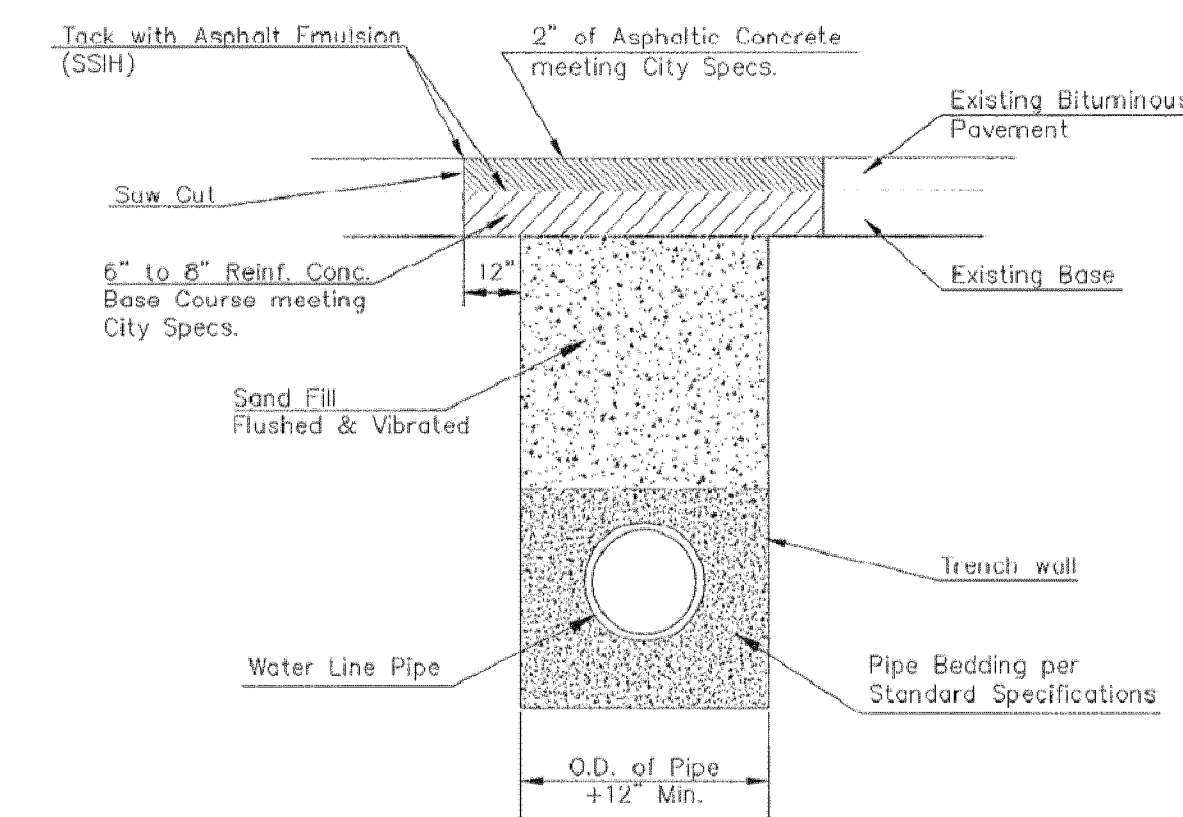

PAVEMENT REPLACEMENT & TRENCH COMPACTION UNDER EXISTING AND PROPOSED CITY ROADS

REVISED: JULY 2015

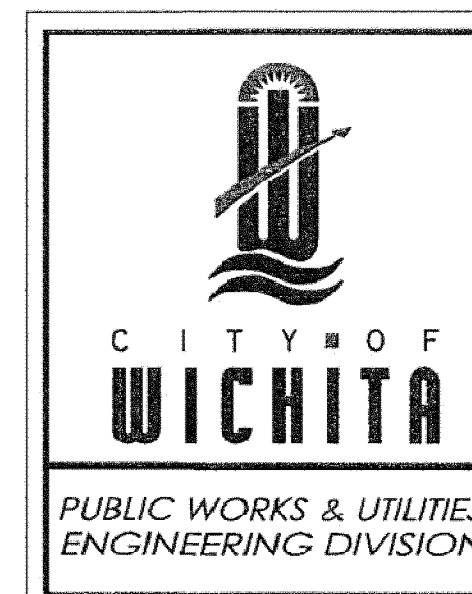
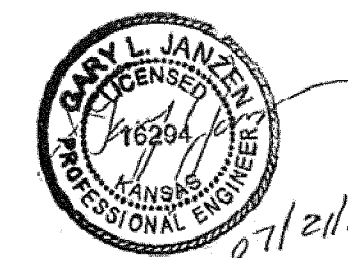

MISCELLANEOUS WATER DETAILS

CITY ENGINEER
GARY JANZEN, P.E.

PROJECT NUMBER	OCA NUMBER	DATE
CITY ENGINEER'S OFFICE		SHEET
CITY HALL - SEVENTH FLOOR 455 NORTH MAIN STREET WICHITA, KANSAS 67202-1620 (316) 268-4501		

WL-104

NO.	BY	DATE	REVISION
3.	JMD	MES 3/10/16	AS PER CITY COMMENTS
2.	JMD	MES 3/09/16	AS PER CITY COMMENTS
1.	JMD	MES 3/02/16	AS PER CITY COMMENTS
			ORIGINAL SUBMITTAL

Renaissance Infrastructure Consulting
913.317.9500
WWW.RIC-CONSULT.COM
1138 W. CARBIDE CIRCLE DRIVE
KANSAS CITY, KANSAS 64103

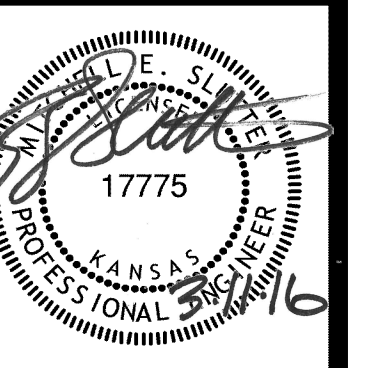

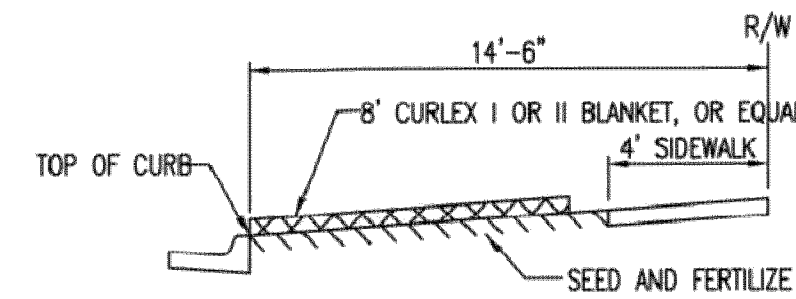

SECTION B-B

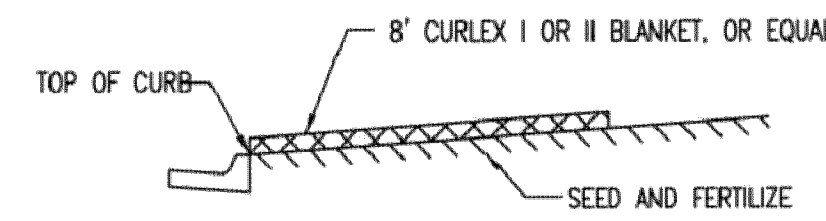

SECTION A-A

INSTALL 8" WIDE CURLEX I OR II EXCELSIOR BLANKET, OR EQUAL, ON PREPARED SURFACE BACK OF CURB. EDGE OF BLANKET WILL BE AT BACK OF CURB. INSTALL PER MANUFACTURERS RECOMMENDATION, INCLUDING STAPLES. (SEE DETAIL)

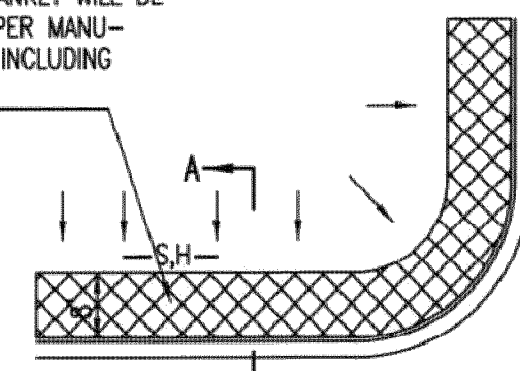

SOUTH STREET

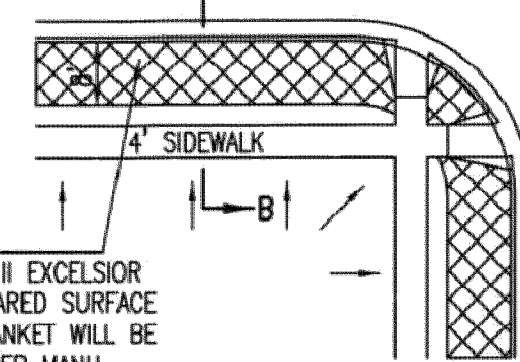

INSTALL 8" WIDE CURLEX I OR II EXCELSIOR BLANKET, OR EQUAL, ON PREPARED SURFACE BACK OF CURB. EDGE OF BLANKET WILL BE AT BACK OF CURB. INSTALL PER MANUFACTURERS RECOMMENDATION, INCLUDING STAPLES. (SEE DETAIL)

GENERAL NOTES

- EXCELSIOR MAT TO BE INSTALLED WHEN SOD IS NOT SPECIFIED ON PROJECT.
- EXCELSIOR BLANKET TO BE INSTALLED OVER SEED AND FERTILIZER, AS SPECIFIED IN THE PROJECT SPECIFICATIONS.
- AFTER INSTALLATION OF EXCELSIOR BLANKET, AT LOCATIONS WHERE CONCENTRATED FLOW CARRIES SEDIMENT OVER THE CURB AND INTO THE CUTTER, SUPPLEMENTAL EROSION CONTROL DEVICES WILL BE INSTALLED BY THE CONTRACTOR AS NEEDED, TO FIX THE PROBLEM.

BACK OF CURB PROTECTION DETAIL

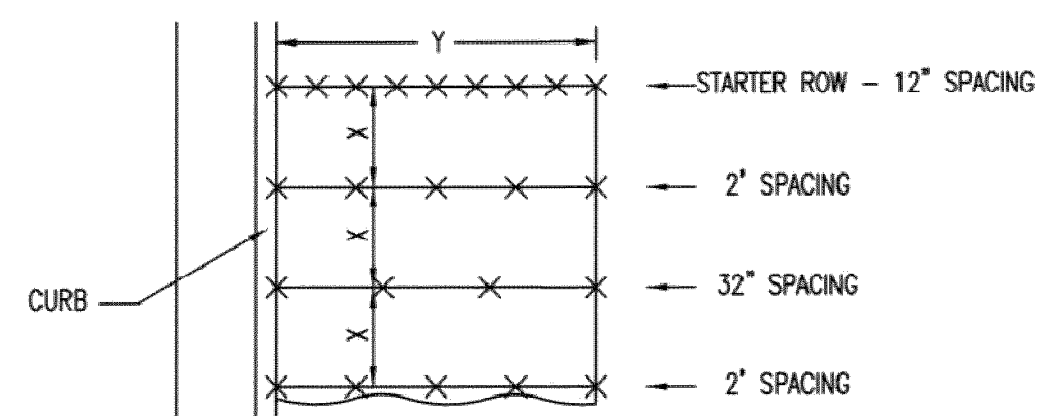

STAPLE PATTERN

NOTES: USE 6" SEAM OVERLAP
(X & Y = RECOMMENDED BY MANUFACTURE)

DETAILS FOR APPROVED EROSION CONTROL MAT

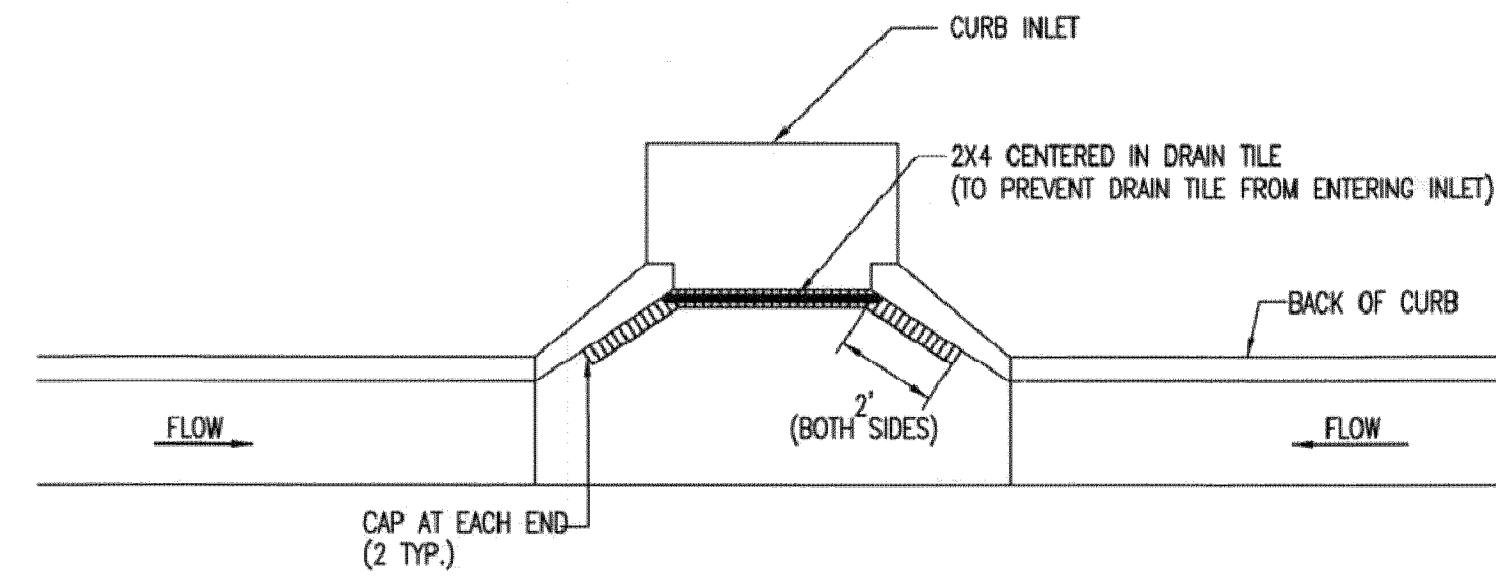

NOTE: PLACE 4" PERFORATED PVC PIPE, FILLED WITH 1/2"-1" DIA. GRAVEL, IN FRONT OF CURB INLET AS SHOWN.

2X4 LENGTH	INLET TYPE	INLET OPENING
5'-6"	1-A	5'-0"
10'-6"	1-A	10'-0"
15'-6"	1-A	15'-0"

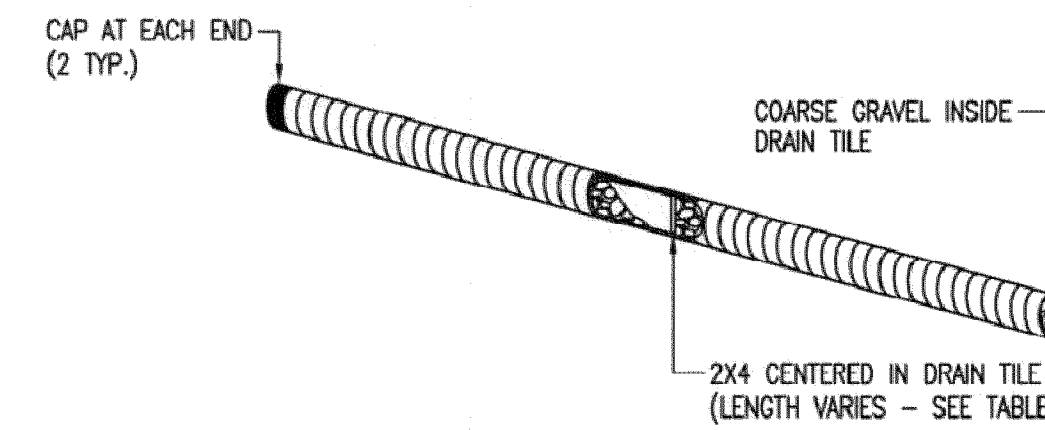

CURB INLET PROTECTION
4" PERFORATED PIPE W/ GRAVEL

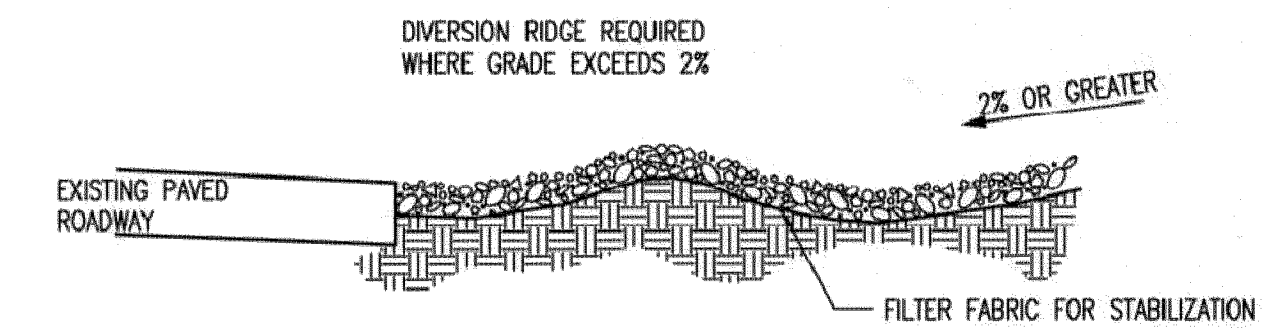

SECTION C-C

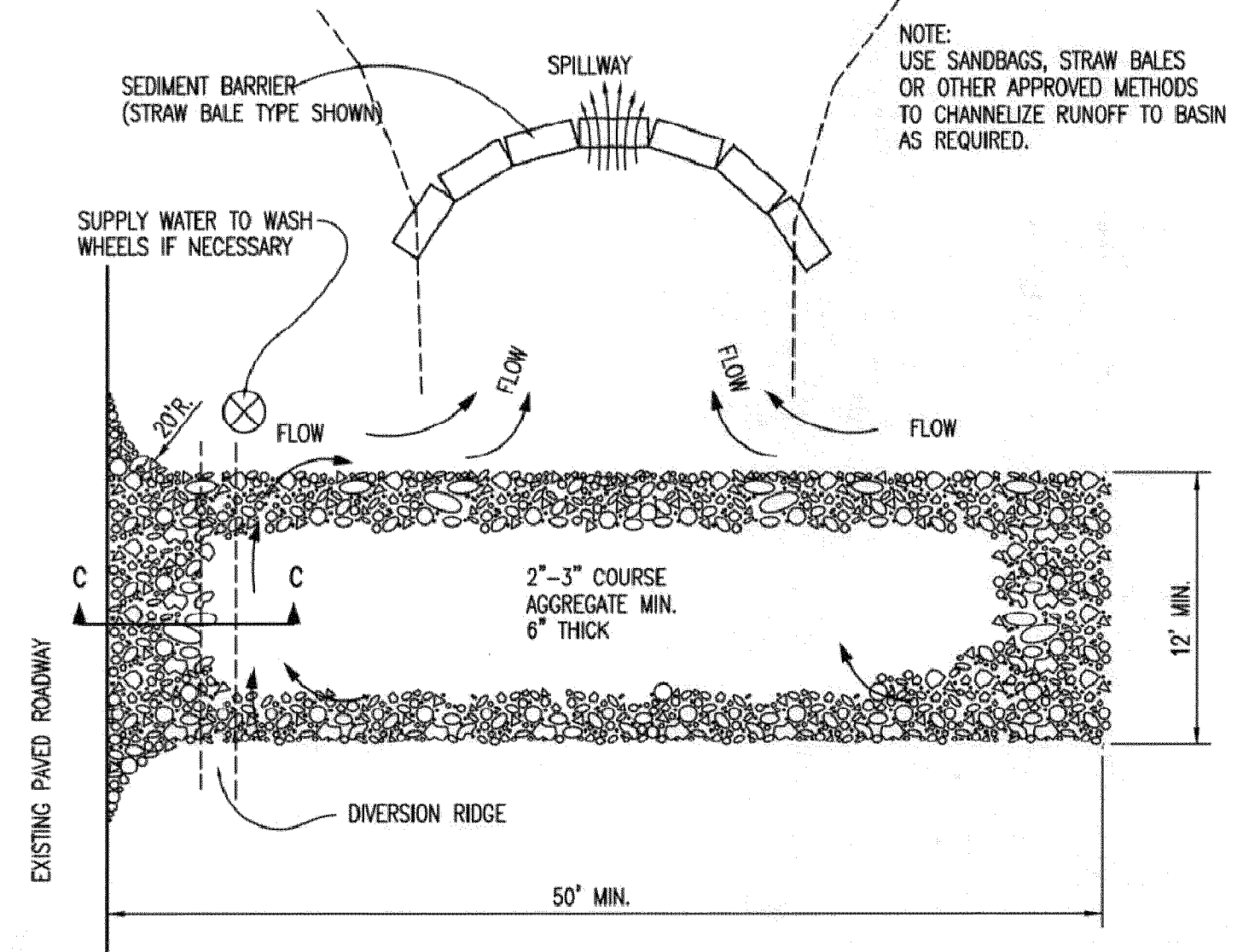

STABILIZED CONSTRUCTION ENTRANCE

GENERAL NOTES

- THE ENTRANCE SHALL BE MAINTAINED IN A CONDITION THAT WILL PREVENT TRACKING OR FLOWING OF SEDIMENT ONTO PUBLIC RIGHTS-OF-WAY. THIS MAY REQUIRE TOP DRESSING, REPAIR AND/OR CLEANOUT OF ANY MEASURES USED TO TRAP SEDIMENT.
- WHEN NECESSARY, WHEELS SHALL BE CLEANED PRIOR TO ENTRANCE ONTO PUBLIC RIGHT-OF-WAY.
- WHEN WASHING IS REQUIRED, IT SHALL BE DONE ON AN AREA STABILIZED WITH CRUSHED STONE THAT DRAINS INTO AN APPROVED SEDIMENT TRAP OR SEDIMENT BASIN, AS SHOWN ABOVE.
- DRIVE ENTRANCES ONTO RESIDENTIAL LOTS WILL NOT BE REQUIRED TO HAVE THE SEDIMENT BARRIER SHOWN, BUT WHEEL WASHING MAY BE REQUIRED IF STABILIZED ENTRANCE IS NOT SUFFICIENT TO KEEP MUD FROM BEING TRACKED ONTO ADJACENT STREET. ENTRANCE SHALL EXTEND FROM BACK OF CURB TO DWELLING.

REVISION DATE: MAY 2013

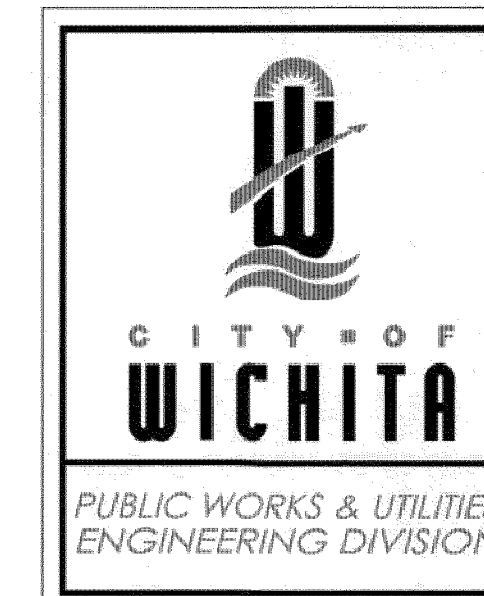

BACK OF CURB PROTECTION,
CURB INLET PROTECTION AND
CONSTRUCTION ENTRANCE

CITY ENGINEER
GARY JANZEN, P.E.

PROJECT NUMBER OCA NUMBER DATE

CITY ENGINEER'S OFFICE SHEET

CITY HALL - SEVENTH FLOOR
455 NORTH MAIN STREET
WICHITA, KANSAS 67202-1620
(316) 268-4501

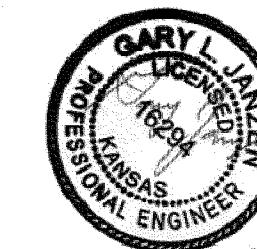

05/20/13

SW-501

Renaissance
Infrastructure
Consulting

913.317.9500
WWW.RIC-CONSULT.COM

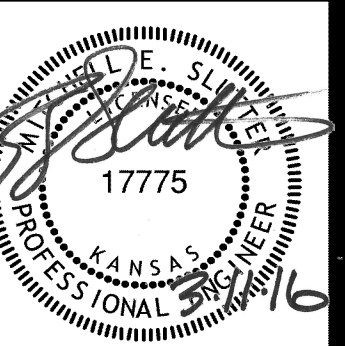
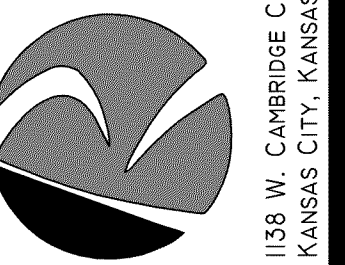

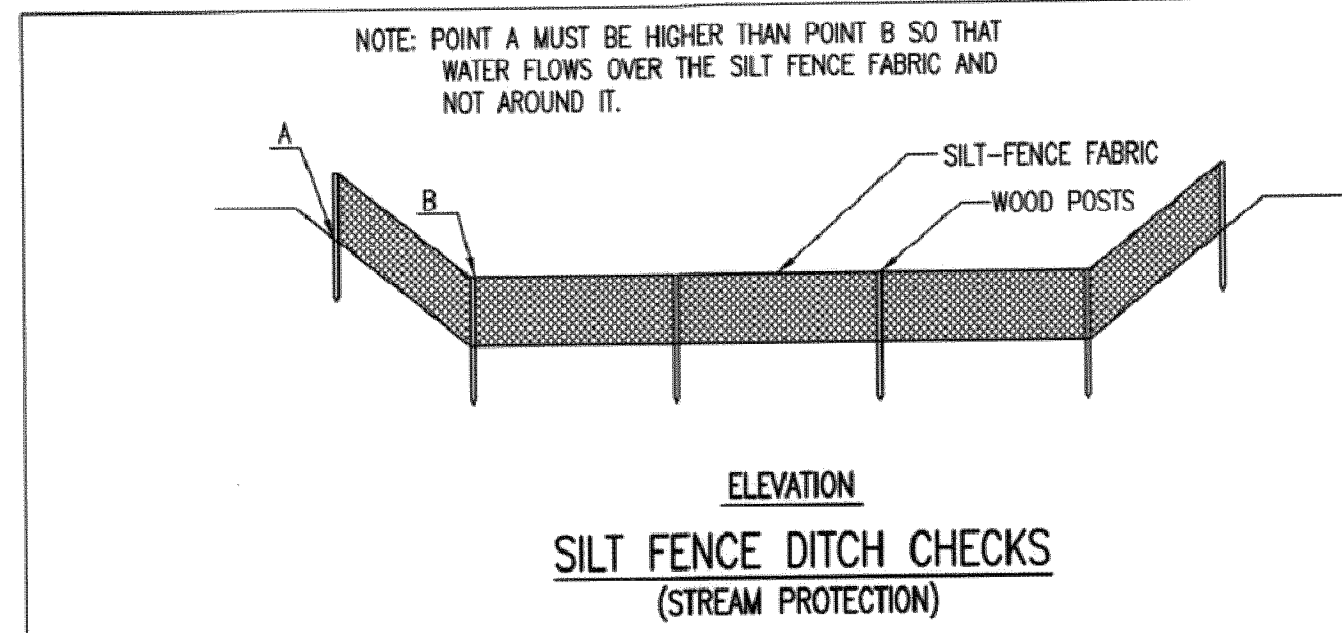

MATERIAL SPECIFICATION:

SILT FENCE FABRIC SHOULD CONFORM TO THE AASHTO M288 96 SILT FENCE SPECIFICATION. THE POSTS USED TO SUPPORT THE SILT FENCE FABRIC SHOULD BE A HARDWOOD MATERIAL WITH THE FOLLOWING MINIMUM DIMENSIONS: 2" SQUARE (NOMINAL) BY 4' LONG. SILT FENCE FABRIC SHOULD BE ATTACHED TO THE WOODEN POSTS WITH STAPLES, WIRE, ZIP TIES, OR NAILS.

PLACEMENT:

PLACE SILT FENCE IN DITCHES WHERE IT IS UNLIKELY THAT IT WILL BE OVERTOPPED. WATER SHOULD FLOW THROUGH A SILT FENCE DITCH CHECK, NOT OVER IT. SILT FENCE DITCH CHECKS OFTEN FAIL WHEN OVERTOPPED. SILT FENCE DITCH CHECKS SHOULD BE PLACED PERPENDICULAR TO THE FLOWLINE OF THE DITCH. THE SILT FENCE SHOULD EXTEND FAR ENOUGH SO THAT THE GROUND LEVEL AT THE ENDS OF THE FENCE IS HIGHER THAN THE TOP OF THE LOW POINT OF THE FENCE. THIS PREVENTS WATER FROM FLOWING AROUND THE CHECK. SILT FENCE DITCH CHECKS SHOULD NOT BE PLACED IN DITCHES WHERE HIGH FLOWS ARE EXPECTED. ROCK CHECKS SHOULD BE USED INSTEAD. SILT FENCE SHOULD BE PLACED IN DITCHES WITH SLOPES OF 6% OR LESS. FOR SLOPES STEEPER THAN 6%, ROCK CHECKS SHOULD BE USED.

THE FOLLOWING TABLE PROVIDES CHECK SPACING FOR A GIVEN DITCH GRADE:

DITCH CHECK DITCH GRADE (%)	SPACING CHECK SPACING (FEET)
0.5	200
1.0	200
2.0	100
3.0	65
4.0	50
5.0	40
6.0	30

PROPER INSTALLATION METHOD:

EXCAVATE A TRENCH PERPENDICULAR TO THE DITCH FLOWLINE THAT IS AT LEAST 12" DEEP BY 6" WIDE. EXTEND THE TRENCH IN A STRAIGHT LINE ALONG THE ENTIRE LENGTH OF THE PROPOSED DITCH CHECK. PLACE THE SOIL ON THE UPSTREAM SIDE OF THE TRENCH FOR LATER USE. ROLL OUT A CONTINUOUS LENGTH OF SILT FENCE FABRIC ON THE DOWNSTREAM SIDE OF THE TRENCH. PLACE THE EDGE OF THE FABRIC IN THE TRENCH STARTING AT THE TOP UPSTREAM EDGE OF THE TRENCH. LINE TWO SIDES OF THE TRENCH WITH THE FABRIC AS SHOWN ON DETAIL. BACKFILL OVER THE FABRIC IN THE TRENCH WITH THE EXCAVATED SOIL AND COMPACT. AFTER FILLING THE TRENCH, APPROXIMATELY 24" TO 36" OF SILT FENCE FABRIC SHOULD REMAIN EXPOSED. LAY THE EXPOSED SILT FENCE ON THE UPSTREAM SIDE OF THE TRENCH TO CLEAR AN AREA FOR DRIVING IN THE POSTS. JUST DOWNSTREAM OF THE TRENCH, DRIVE POSTS INTO THE GROUND TO A DEPTH OF AT LEAST 24". PLACE POSTS NO MORE THAN 4' APART. ATTACH THE SILT FENCE TO THE ANCHORED POST WITH STAPLES, WIRE, ZIP TIES, OR NAILS.

LIST OF COMMON PLACEMENT/INSTALLATION MISTAKES TO AVOID:

WATER SHOULD FLOW THROUGH A SILT FENCE DITCH CHECK—NOT OVER IT. PLACE SILT FENCE IN DITCHES WHERE IT IS UNLIKELY THAT IT WILL BE OVERTOPPED. SILT FENCE INSTALLATIONS QUICKLY DETERIORATE WHEN WATER OVERTOPS THEM. DO NOT PLACE SILT FENCE POSTS ON THE UPSTREAM SIDE OF THE SILT FENCE FABRIC. IN THIS CONFIGURATION, THE FORCE OF THE WATER IS NOT RESTRICTED BY THE POSTS, BUT ONLY BY THE STAPLES (WIRE, ZIP TIES, NAILS, ETC.). THE SILT FENCE WILL RIP AND FAIL. DO NOT PLACE A SILT FENCE DITCH CHECK DIRECTLY IN FRONT OF A CULVERT OUTLET. IT WILL NOT STAND UP TO THE CONCENTRATED FLOW. DO NOT PLACE SILT FENCE DITCH CHECKS IN DITCHES THAT WILL LIKELY EXPERIENCE HIGH FLOWS. THEY WILL NOT STAND UP TO CONCENTRATED FLOW. FOLLOW PRESCRIBED DITCH CHECK SPACING GUIDELINES. IF SPACING GUIDELINES ARE EXCEEDED, EROSION WILL OCCUR BETWEEN THE DITCH CHECKS. DO NOT ALLOW WATER TO FLOW AROUND THE DITCH CHECK. MAKE SURE THAT THE DITCH CHECK IS LONG ENOUGH SO THAT THE GROUND LEVEL AT THE ENDS OF THE FENCE IS HIGHER THAN THE LOW POINT ON THE TOP OF THE FENCE. DO NOT PLACE SILT FENCE DITCH CHECKS IN CHANNELS WITH SHALLOW SOILS UNDERLAIN BY ROCK. IF THE CHECK IS NOT ANCHORED SUFFICIENTLY, IT WILL WASH OUT.

INSPECTION AND MAINTENANCE:

SILT FENCE DITCH CHECKS SHOULD BE INSPECTED EVERY 7 DAYS AND WITHIN 24 HOURS OF A RAINFALL OF 1/2" OR MORE. THE FOLLOWING IS A LIST OF QUESTIONS THAT SHOULD BE ADDRESSED DURING EACH INSPECTION:

- DOES WATER FLOW AROUND THE DITCH CHECK?
- DOES WATER FLOW UNDER THE DITCH CHECK?
- DOES THE SILT FENCE SAG EXCESSIVELY?
- HAS THE SILT FENCE TORN OR BECOME DETACHED FROM THE POSTS?
- DOES SEDIMENT NEED TO BE REMOVED FROM BEHIND THE DITCH CHECK?

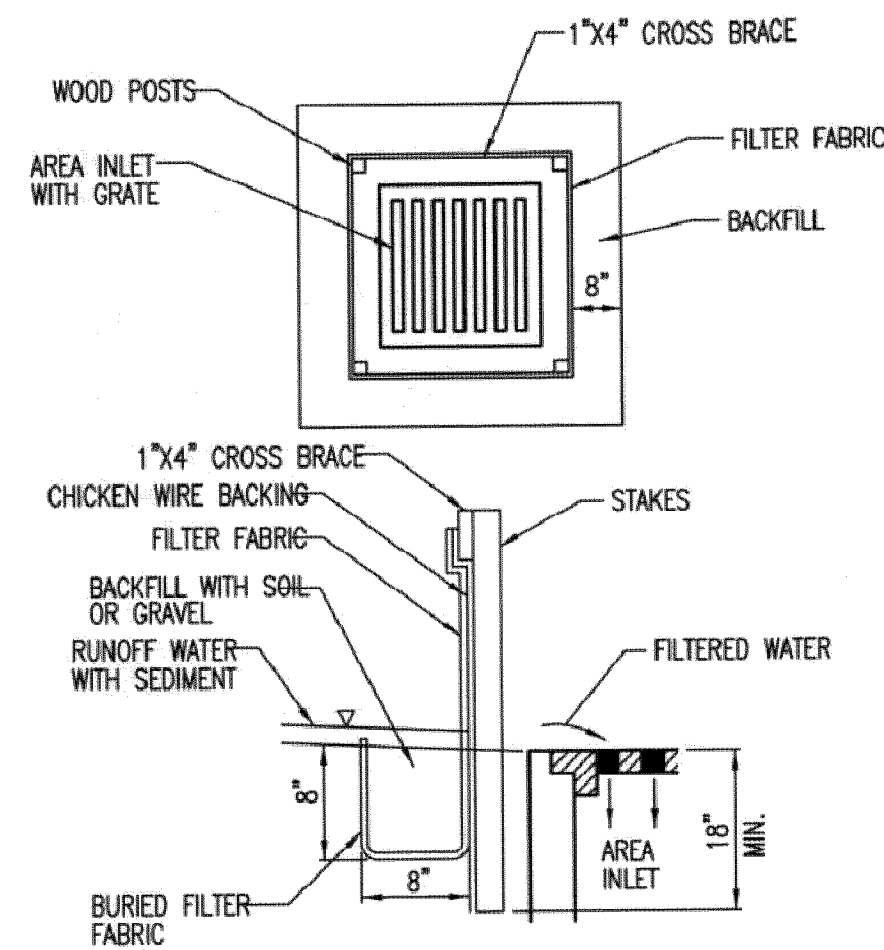
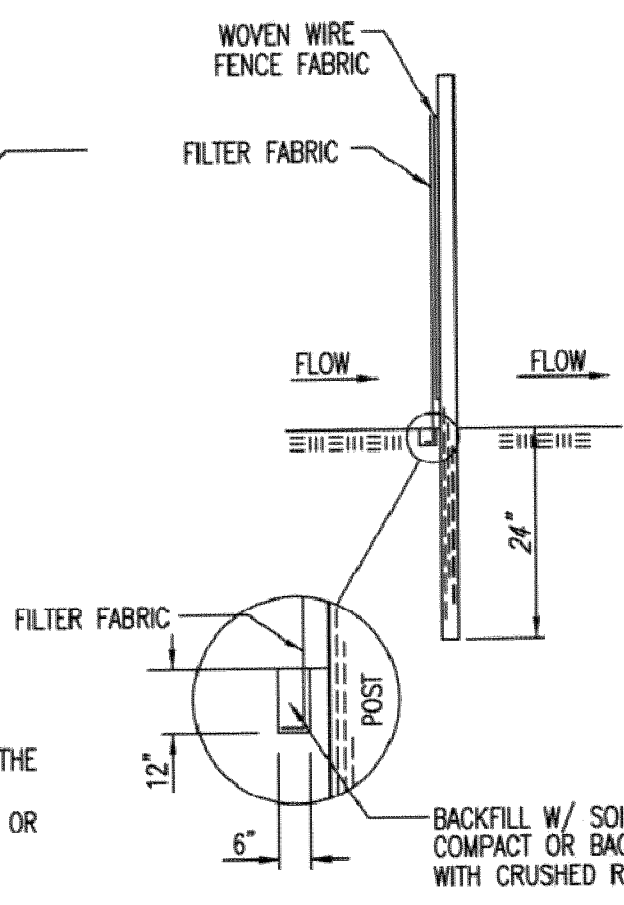

MATERIAL SPECIFICATION:

PLACE A SILT FENCE DROP INLET BARRIER IN A LOCATION WHERE IT IS UNLIKELY TO BE OVERTOPPED. WATER SHOULD FLOW THROUGH SILT FENCE, NOT OVER IT. SILT FENCE BARRIERS FOR AREA INLETS OFTEN FAIL WHEN REPEATEDLY OVERTOPPED. WHEN USED AS A BARRIER FOR AREA INLETS, SILT FENCE FABRIC AND POSTS MUST BE SUPPORTED AT THE TOP BY A WOODEN FRAME. WHEN A SILT FENCE BARRIER FOR AREA INLETS IS LOCATED NEAR AN INLET THAT HAS STEEP APPROACH SLOPES, THE STORAGE CAPACITY BEHIND THE BARRIER IS DRASTICALLY REDUCED. TIMELY REMOVAL OF SEDIMENT MUST OCCUR FOR A BARRIER TO OPERATE PROPERLY IN THIS LOCATION.

PLACEMENT:

EXCAVATE A TRENCH AROUND THE PERIMETER OF THE AREA INLET THAT IS AT LEAST 8" DEEP BY 8" WIDE. DRIVE POSTS TO A DEPTH OF AT LEAST 18" AROUND THE PERIMETER OF THE AREA INLET. THE DISTANCE BETWEEN POSTS SHOULD BE 4' OR LESS. IF THE DISTANCE BETWEEN TWO ADJACENT CORNER POSTS IS MORE THAN 4', ADD ANOTHER POST(S) BETWEEN THEM. CONNECT THE TOPS OF ALL THE POSTS WITH A WOODEN FRAME MADE OF 1" BY 4" BOARDS. USE NAILS OR SCREWS FOR FASTENING. ATTACH THE WIRE OR POLYMERIC-MESH BACKING TO THE OUTSIDE OF THE POST/FRAME STRUCTURE WITH STAPLES, WIRE, ZIP TIES, OR NAILS. ROLL OUT A CONTINUOUS LENGTH OF SILT FENCE FABRIC LONG ENOUGH TO WRAP AROUND THE PERIMETER OF THE AREA INLET. ADD MORE LENGTH FOR OVERLAPPING THE FABRIC JOINT. PLACE THE EDGE OF THE FABRIC IN THE TRENCH, STARTING AT THE OUTSIDE EDGE OF THE TRENCH. LINE ALL THREE SIDES OF THE TRENCH WITH THE FABRIC. BACKFILL OVER THE FABRIC IN THE TRENCH WITH THE EXCAVATED SOIL AND COMPACT. AFTER FILLING THE TRENCH, APPROXIMATELY 24" TO 36" OF SILT FENCE FABRIC SHOULD REMAIN EXPOSED. ATTACH THE SILT FENCE TO THE OUTSIDE OF THE POST/FRAME STRUCTURE WITH STAPLES, WIRE, ZIP TIES, OR NAILS. THE JOINT SHOULD BE OVERLAPPED TO THE NEXT POST.

PROPER INSTALLATION METHOD:

EXCAVATE A TRENCH AROUND THE PERIMETER OF THE AREA INLET THAT IS AT LEAST 8" DEEP BY 8" WIDE. DRIVE POSTS TO A DEPTH OF AT LEAST 18" AROUND THE PERIMETER OF THE AREA INLET. THE DISTANCE BETWEEN POSTS SHOULD BE 4' OR LESS. IF THE DISTANCE BETWEEN TWO ADJACENT CORNER POSTS IS MORE THAN 4', ADD ANOTHER POST(S) BETWEEN THEM. CONNECT THE TOPS OF ALL THE POSTS WITH A WOODEN FRAME MADE OF 1" BY 4" BOARDS. USE NAILS OR SCREWS FOR FASTENING. ATTACH THE WIRE OR POLYMERIC-MESH BACKING TO THE OUTSIDE OF THE POST/FRAME STRUCTURE WITH STAPLES, WIRE, ZIP TIES, OR NAILS. ROLL OUT A CONTINUOUS LENGTH OF SILT FENCE FABRIC LONG ENOUGH TO WRAP AROUND THE PERIMETER OF THE AREA INLET. ADD MORE LENGTH FOR OVERLAPPING THE FABRIC JOINT. PLACE THE EDGE OF THE FABRIC IN THE TRENCH, STARTING AT THE OUTSIDE EDGE OF THE TRENCH. LINE ALL THREE SIDES OF THE TRENCH WITH THE FABRIC. BACKFILL OVER THE FABRIC IN THE TRENCH WITH THE EXCAVATED SOIL AND COMPACT. AFTER FILLING THE TRENCH, APPROXIMATELY 24" TO 36" OF SILT FENCE FABRIC SHOULD REMAIN EXPOSED. ATTACH THE SILT FENCE TO THE OUTSIDE OF THE POST/FRAME STRUCTURE WITH STAPLES, WIRE, ZIP TIES, OR NAILS. THE JOINT SHOULD BE OVERLAPPED TO THE NEXT POST.

PROPER INSTALLATION METHOD:

NOTE: WHEN A SILT FENCE BARRIER FOR AREA INLET IS PLACED IN A SHALLOW MEDIAN DITCH, MAKE SURE THAT THE TOP OF THE BARRIER IS NOT HIGHER THAN THE PAVED ROAD. IN THIS CONFIGURATION, WATER MAY SPREAD ONTO THE ROADWAY CAUSING A HAZARDOUS CONDITION.

LIST OF COMMON PLACEMENT/INSTALLATION MISTAKES TO AVOID:

WATER SHOULD FLOW THROUGH A SILT FENCE BARRIER FOR AREA INLET—NOT OVER IT. PLACE A SILT FENCE BARRIER FOR AREA INLET IN A LOCATION WHERE IT IS UNLIKELY TO BE OVERTOPPED. SILT FENCE BARRIER FOR AREA INLETS OFTEN FAIL WHEN REPEATEDLY OVERTOPPED. DO NOT PLACE POSTS ON THE OUTSIDE OF THE SILT FENCE BARRIER FOR AREA INLET. IN THIS CONFIGURATION, THE FORCE OF THE WATER IS NOT RESTRICTED BY THE POSTS, BUT ONLY BY THE STAPLES (WIRE, ZIP TIES, NAILS, ETC.). THE SILT FENCE WILL RIP AND FAIL. DO NOT INSTALL SILT FENCE BARRIER FOR AREA INLETS WITHOUT FRAMING THE TOP OF THE POSTS. THE CORNER POSTS AROUND AREA INLETS ARE STRESSED IN TWO DIRECTIONS WHEREAS A NORMAL SILT FENCE IS ONLY STRESSED IN ONE DIRECTION. THIS ADDED STRESS REQUIRES MORE SUPPORT.

INSPECTION AND MAINTENANCE:

SILT FENCE BARRIER FOR AREA INLETS SHOULD BE INSPECTED EVERY 7 DAYS AND WITHIN 24 HOURS OF A RAINFALL OF 1/2" OR MORE. THE FOLLOWING IS A LIST OF QUESTIONS THAT SHOULD BE ADDRESSED DURING EACH INSPECTION:

- DOES WATER FLOW UNDER THE SILT FENCE?
- DOES THE SILT FENCE SAG EXCESSIVELY?
- HAS THE SILT FENCE TORN OR BECOME DETACHED FROM THE POSTS?
- DOES SEDIMENT NEED TO BE REMOVED FROM BEHIND THE AREA INLET BARRIER?

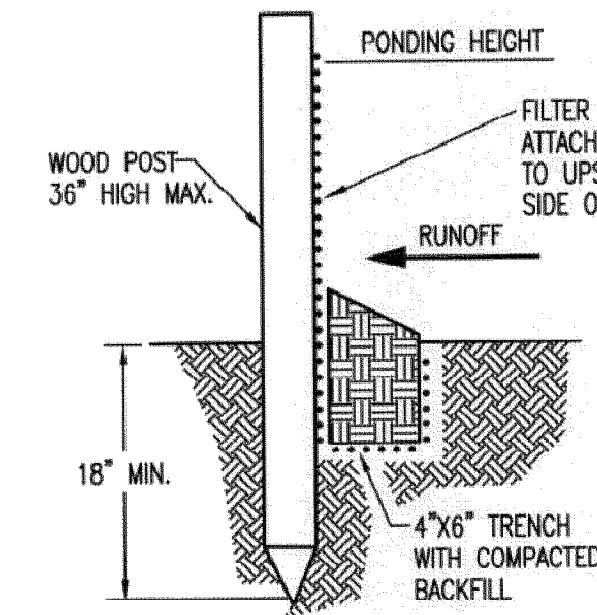

MATERIAL SPECIFICATION:

SILT FENCE FABRIC SHOULD CONFORM TO THE AASHTO M288 96 SILT FENCE SPECIFICATION. THE POSTS USED TO SUPPORT THE SILT FENCE FABRIC SHOULD BE A HARDWOOD MATERIAL WITH THE FOLLOWING MINIMUM DIMENSIONS: 2" SQUARE (NOMINAL) BY 4' LONG. SILT FENCE FABRIC SHOULD BE ATTACHED TO THE WOODEN POSTS WITH STAPLES, WIRE, ZIP TIES, OR NAILS.

PLACEMENT:

A SLOPE BARRIER SHOULD BE USED AT THE TOE OF A SLOPE WHEN A DITCH DOES NOT EXIST. THE SLOPE BARRIER SHOULD BE PLACED ON NEARLY LEVEL GROUND 5' TO 10' AWAY FROM THE TOE OF A SLOPE. THE BARRIER IS PLACED AWAY FROM THE TOE OF THE SLOPE TO PROVIDE ADEQUATE STORAGE FOR SETTLING OUT SEDIMENT. WHEN PRACTICABLE, SILT FENCE SLOPE BARRIERS SHOULD BE PLACED ALONG CONTOURS TO AVOID A CONCENTRATION OF FLOW. SILT FENCE SLOPE BARRIERS CAN ALSO BE PLACED ALONG RIGHT-OF-WAY FENCE LINES TO KEEP SEDIMENT FROM CROSSING ONTO ADJACENT PROPERTY. WHEN PLACED IN THIS MANNER, THE SLOPE BARRIER WILL NOT LIKELY FOLLOW CONTOURS.

PROPER INSTALLATION METHOD:

EXCAVATE A TRENCH THE LENGTH OF THE PLANNED SLOPE BARRIER THAT IS 6" DEEP BY 4" WIDE. MAKE SURE THAT THE TRENCH IS EXCAVATED ALONG A SINGLE CONTOUR. WHEN PRACTICABLE, SLOPE BARRIERS SHOULD BE PLACED ALONG CONTOURS TO AVOID A CONCENTRATION OF FLOW. PLACE THE SOIL ON THE UPSLOPE SIDE OF THE TRENCH FOR LATER USE. ROLL OUT A CONTINUOUS LENGTH OF SILT FENCE FABRIC ON THE DOWNSLOPE SIDE OF THE TRENCH. PLACE THE EDGE OF THE FABRIC IN THE TRENCH STARTING AT THE TOP UPSLOPE EDGE. LINE ALL THREE SIDES OF THE TRENCH WITH THE FABRIC. BACKFILL OVER THE FABRIC IN THE TRENCH WITH THE EXCAVATED SOIL AND COMPACT. AFTER FILLING THE TRENCH, APPROXIMATELY 24" TO 36" OF SILT-FENCE FABRIC SHOULD REMAIN EXPOSED. LAY THE EXPOSED SILT FENCE UPSLOPE OF THE TRENCH TO CLEAR AN AREA FOR DRIVING IN THE POSTS. JUST DOWNSLOPE OF THE TRENCH, DRIVE POSTS INTO THE GROUND TO A DEPTH OF AT LEAST 18". PLACE POSTS NO MORE THAN 4' APART. ATTACH THE SILT FENCE TO THE ANCHORED POST WITH STAPLES, WIRE, ZIP TIES, OR NAILS.

LIST OF COMMON PLACEMENT/INSTALLATION MISTAKES TO AVOID:

WHEN PRACTICABLE, DO NOT PLACE SILT FENCE SLOPE BARRIERS ACROSS CONTOURS. SLOPE BARRIERS SHOULD BE PLACED ALONG CONTOURS TO AVOID A CONCENTRATION OF FLOW. WHEN THE FLOW CONCENTRATES, IT OVERTOPS THE BARRIER AND THE SILT FENCE SLOPE BARRIER QUICKLY DETERIORATES. DO NOT PLACE SILT-FENCE POSTS ON THE UPSLOPE SIDE OF THE SILT FENCE FABRIC. IN THIS CONFIGURATION, THE FORCE OF THE WATER IS NOT RESTRICTED BY THE POSTS, BUT ONLY BY THE STAPLES (WIRE, ZIP TIES, NAILS, ETC.). THE SILT FENCE WILL RIP AND FAIL. DO NOT PLACE SILT FENCE SLOPE BARRIERS IN AREAS WITH SHALLOW SOILS UNDERLAIN BY ROCK. IF THE BARRIER IS NOT SUFFICIENTLY ANCHORED, IT WILL WASH OUT. SILT FENCE SLOPE BARRIERS MUST BE DUG INTO THE GROUND—SILT FENCE AT GROUND LEVEL DOES NOT WORK BECAUSE WATER WILL FLOW UNDERNEATH.

INSPECTION AND MAINTENANCE:

SILT FENCE SLOPE BARRIERS SHOULD BE INSPECTED EVERY 7 DAYS AND WITHIN 24 HOURS OF A RAINFALL OF 1/2" OR MORE. THE FOLLOWING IS A LIST OF QUESTIONS THAT SHOULD BE ADDRESSED DURING EACH INSPECTION:

- ARE THERE ANY POINTS ALONG THE SLOPE BARRIER WHERE WATER IS CONCENTRATING?
- DOES WATER FLOW UNDER THE SLOPE BARRIER?
- DO THE SILT FENCES SAG EXCESSIVELY?
- HAS THE SILT FENCE TORN OR BECOME DETACHED FROM THE POSTS?
- DOES SEDIMENT NEED TO BE REMOVED FROM BEHIND THE SLOPE BARRIER?

REVISION DATE: MAY 2013

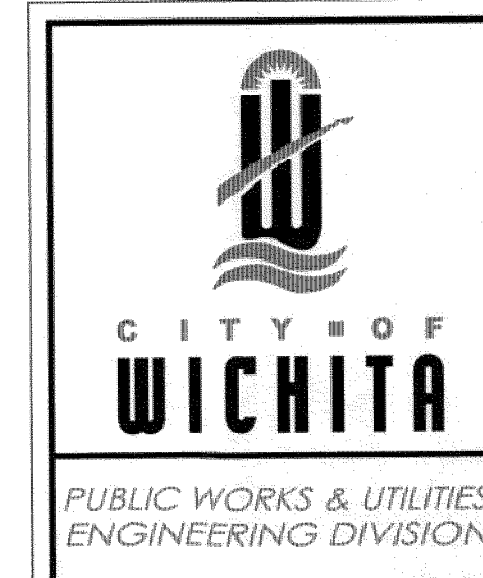

SILT FENCE DITCH CHECK AND BARRIER DETAILS

CITY ENGINEER
GARY JANZEN, P.E.

PROJECT NUMBER OCA NUMBER DATE

CITY ENGINEER'S OFFICE
CITY HALL - SEVENTH FLOOR
455 NORTH MAIN STREET
WICHITA, KANSAS 67202-1620
(316) 268-4501

SW-502

Renaissance
Infrastructure
Consulting

913.317.9500
WWW.RIC-CONSULT.COM

1138 W. CARBONDALE DRIVE
KANSAS CITY, KANSAS 64103

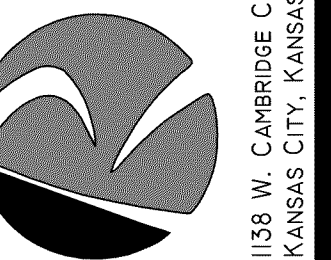

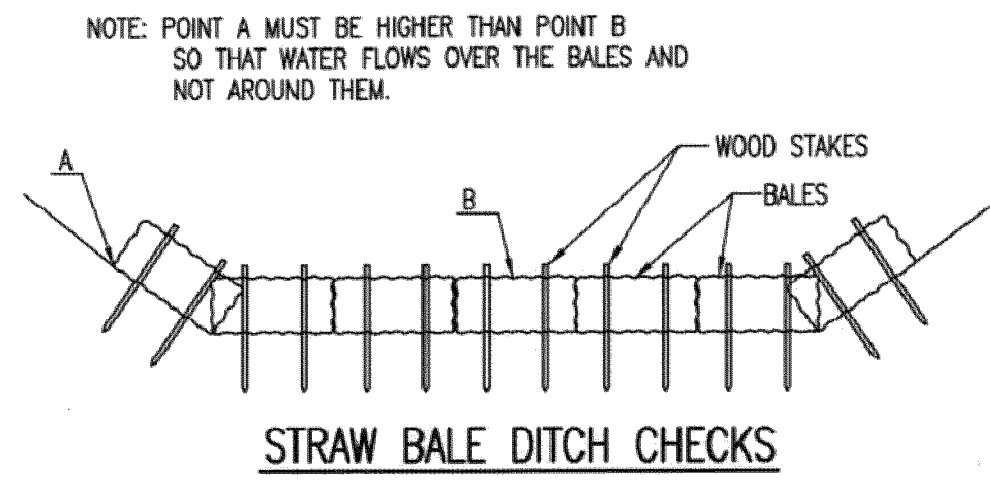

STRAW BALE DITCH CHECKS

MATERIAL SPECIFICATION:
BALE DITCH CHECKS MAY BE CONSTRUCTED OF WHEAT STRAW, OAT STRAW, PRAIRIE HAY, OR BROMEGRASS HAY THAT IS FREE OF WEEDS DECLARED NOXIOUS BY THE KANSAS STATE BOARD OF AGRICULTURE. THE STAKES USED TO ANCHOR THE BALES SHOULD BE A HARDWOOD MATERIAL WITH THE FOLLOWING MINIMUM DIMENSIONS: 2" SQUARE (NOMINAL) BY 4' LONG. OPTIONAL: THE DOWNSTREAM SCOUR APRON SHOULD BE CONSTRUCTED OF A DOUBLE-NETTED STRAW EROSION-CONTROL BLANKET AT LEAST 6' WIDE. OPTIONAL: THE METAL LANDSCAPE STAPLES USED TO ANCHOR THE EROSION-CONTROL BLANKET SHOULD BE AT LEAST 8" LONG.

PLACEMENT:
BALE DITCH CHECKS SHOULD BE PLACED PERPENDICULAR TO THE FLOWLINE OF THE DITCH. THE DITCH CHECK SHOULD EXTEND FAR ENOUGH SO THAT THE GROUND LEVEL AT THE ENDS OF THE CHECK IS HIGHER THAN THE TOP OF THE LOWEST CENTER BALE. THIS PREVENTS WATER FROM FLOWING AROUND THE CHECK. STRAW BALE DITCH CHECKS SHOULD NOT BE PLACED IN DITCHES WHERE HIGH FLOWS ARE EXPECTED. ROCK CHECKS SHOULD BE USED INSTEAD. BALES SHOULD BE PLACED IN DITCHES WITH SLOPES OF 6% OR LESS. FOR SLOPES STEEPER THAN 6%, ROCK CHECKS SHOULD BE USED. THE FOLLOWING TABLE PROVIDES CHECK SPACING FOR A GIVEN DITCH GRADE:

DITCH GRADE (%)	CHECK SPACING (FEET)
0.5	200
1.0	200
2.0	100
3.0	65
4.0	50
5.0	40
6.0	30

PROPER INSTALLATION METHOD:
EXCAVATE A TRENCH PERPENDICULAR TO THE DITCH FLOWLINE THAT IS 4" DEEP AND A BALE'S WIDTH WIDE. EXTEND THE TRENCH IN A STRAIGHT LINE ALONG THE ENTIRE LENGTH OF THE PROPOSED DITCH CHECK. PLACE THE SOIL ON THE UPSTREAM SIDE OF THE TRENCH-IT WILL BE USED LATER. OPTIONAL: ON THE DOWNSTREAM SIDE OF THE TRENCH, ROLL OUT A LENGTH OF EROSION-CONTROL BLANKET (SCOUR APRON) EQUAL TO THE LENGTH OF THE TRENCH. PLACE THE UPSTREAM EDGE OF THE EROSION-CONTROL BLANKET ALONG THE BOTTOM UPSTREAM EDGE OF THE TRENCH. THE EROSION CONTROL BLANKET SHOULD BE ANCHORED IN THE TRENCH WITH ONE ROW OF 8" LANDSCAPE STAPLES PLACED ON 18" CENTERS. THE REMAINDER OF THE EROSION-CONTROL BLANKET (THE PORTION THAT IS NOT LYING IN THE TRENCH) WILL SERVE AS THE DOWNSTREAM SCOUR APRON. THIS SECTION OF THE BLANKET SHOULD BE ANCHORED TO THE GROUND WITH 8" LANDSCAPE STAPLES PLACED AROUND THE PERIMETER OF THE BLANKET ON 18" CENTERS. THE REMAINDER OF THE BLANKET SHOULD BE ANCHORED USING TWO EVENLY SPACED ROWS OF 8" LANDSCAPE STAPLES ON 18" CENTERS PLACED PERPENDICULAR TO THE FLOWLINE OF THE DITCH. PLACE THE BALES IN THE TRENCH, MAKING SURE THAT THEY ARE BUTTED TIGHTLY. TWO STAKES SHOULD BE DRIVEN THROUGH EACH BALE ALONG THE CENTERLINE OF THE DITCH CHECK, APPROXIMATELY 6" TO 8" IN FROM THE BALE ENDS. STAKES SHOULD BE DRIVEN AT LEAST 12" INTO THE GROUND. ONCE ALL THE BALES HAVE BEEN INSTALLED AND ANCHORED, PLACE THE EXCAVATED SOIL AGAINST THE UPSTREAM SIDE OF THE CHECK AND COMPACT IT. THE COMPACTED SOIL SHOULD BE NO MORE THAN 3" TO 4" DEEP AND EXTEND UPSTREAM NO MORE THAN 24".

LIST OF COMMON PLACEMENT/INSTALLATION MISTAKES TO AVOID:
DO NOT PLACE A BALE DITCH CHECK DIRECTLY IN FRONT OF A CULVERT OUTLET. IT WILL NOT STAND UP TO THE CONCENTRATED FLOW.
DO NOT PLACE BALE DITCH CHECKS IN DITCHES THAT WILL LIKELY EXPERIENCE HIGH FLOWS. THEY WILL NOT STAND UP TO CONCENTRATED FLOW.
FOLLOW PRESCRIBED DITCH-CHECK SPACING GUIDELINES. IF SPACING GUIDELINES ARE EXCEEDED, EROSION WILL OCCUR BETWEEN THE DITCH CHECKS.
DO NOT ALLOW WATER TO FLOW AROUND THE DITCH CHECK. MAKE SURE THAT THE DITCH CHECK IS LONG ENOUGH SO THAT THE GROUND LEVEL AT THE ENDS OF THE CHECK IS HIGHER THAN THE TOP OF THE LOWEST CENTER BALE.
DO NOT PLACE BALE DITCH CHECKS IN CHANNELS WITH SHALLOW SOILS UNDERLAIN BY ROCK. IF THE CHECK IS NOT ANCHORED SUFFICIENTLY, IT WILL WASH OUT.
BALE DITCH CHECKS MUST BE DUG INTO THE GROUND. BALES AT GROUND LEVEL DO NOT WORK BECAUSE THEY ALLOW WATER TO FLOW UNDER THE CHECK.

INSPECTION AND MAINTENANCE:
BALE DITCH CHECKS SHOULD BE INSPECTED EVERY 7 DAYS AND WITHIN 24 HOURS OF A RAINFALL OF 1/2" OR MORE. THE FOLLOWING IS A LIST OF QUESTIONS THAT SHOULD BE ADDRESSED DURING EACH INSPECTION:

- DOES WATER FLOW AROUND THE DITCH CHECK?
- DOES WATER FLOW UNDER THE DITCH CHECK?
- DOES WATER FLOW THROUGH SPACES BETWEEN ABUTTING BALES?
- ARE ANY BALES AND/OR SCOUR APRONS (OPTIONAL) DISLODGED?
- ARE BALES DECOMPOSING DUE TO AGE AND/OR WATER DAMAGE?
- DOES SEDIMENT NEED TO BE REMOVED FROM BEHIND THE DITCH CHECK?

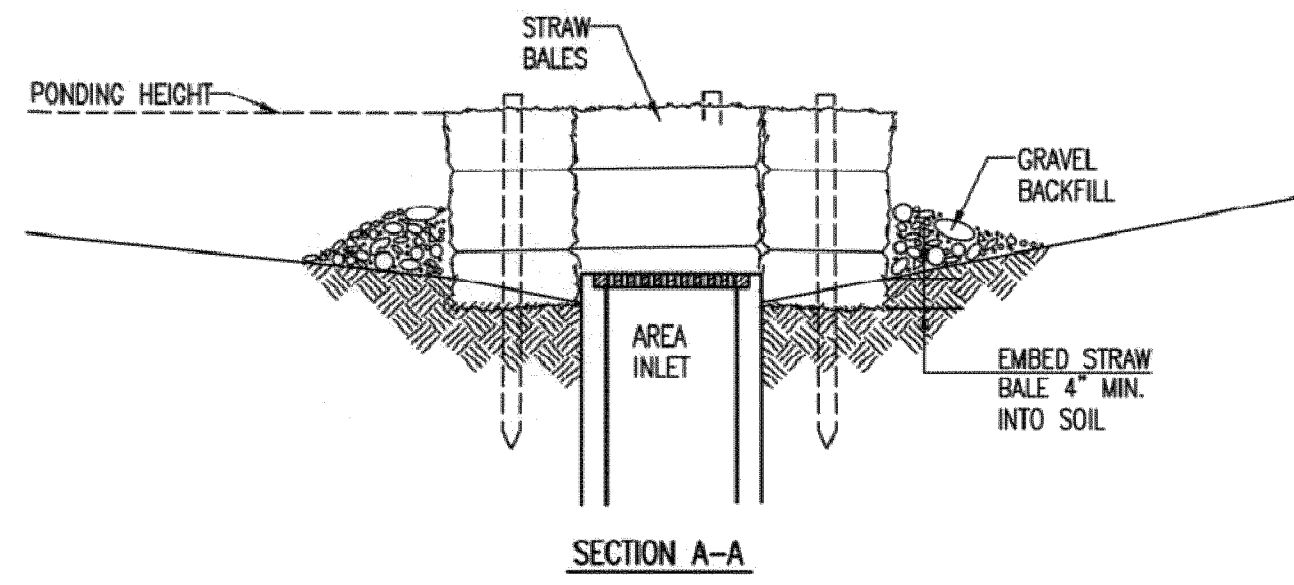

SECTION A-A

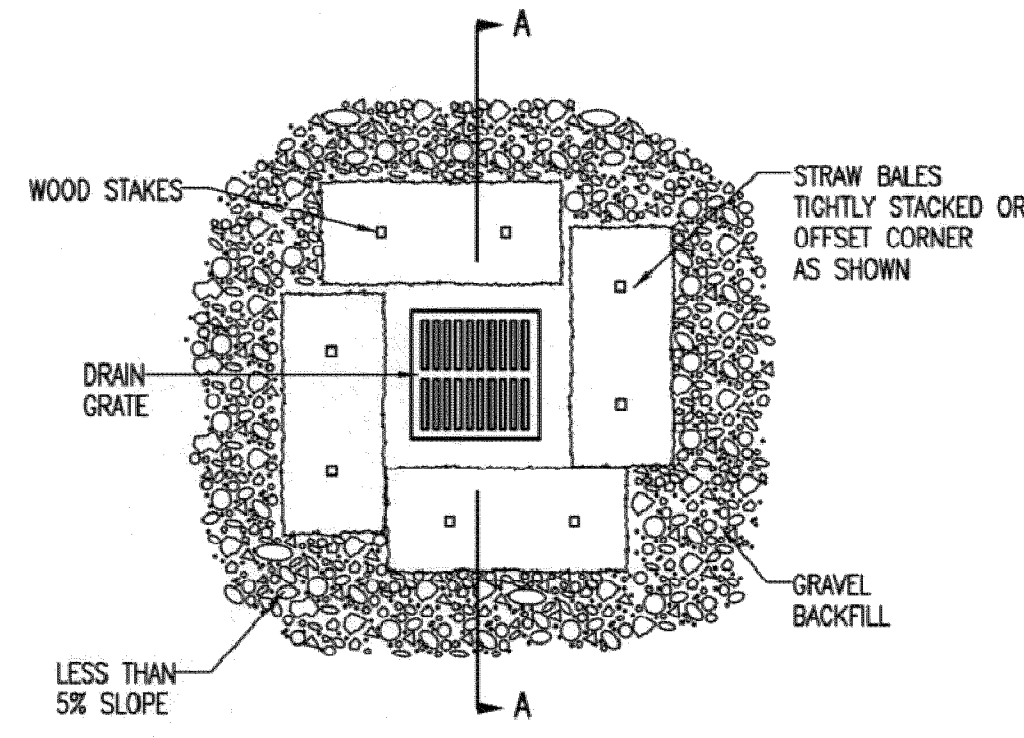

STRAW BALE BARRIERS FOR AREA INLETS
(INLET PROTECTION)

MATERIAL SPECIFICATION:
BALE AREA INLET BARRIERS SHOULD BE CONSTRUCTED OF WHEAT STRAW, OAT STRAW, PRAIRIE HAY, OR BROMEGRASS HAY THAT IS FREE OF WEEDS DECLARED NOXIOUS BY THE KANSAS STATE BOARD OF AGRICULTURE. THE STAKES USED TO ANCHOR THE BALES SHOULD BE A HARDWOOD MATERIAL WITH THE FOLLOWING MINIMUM DIMENSIONS: 2" SQUARE (NOMINAL) BY 4' LONG. TWINE SHOULD BE USED TO BIND BALES. THE USE OF WIRE BINDING IS PROHIBITED BECAUSE IT DOES NOT BIODEGRADE READILY.

PLACEMENT:
BALE AREA INLET BARRIERS SHOULD BE PLACED DIRECTLY AROUND THE PERIMETER OF A DROP INLET. WHEN A BALE AREA INLET BARRIER IS LOCATED NEAR AN INLET THAT HAS STEEP APPROACH SLOPES, THE STORAGE CAPACITY BEHIND THE BARRIER IS DRASTICALLY REDUCED. TIMELY REMOVAL OF SEDIMENT MUST OCCUR FOR A BARRIER TO OPERATE PROPERLY IN THIS LOCATION.

PROPER INSTALLATION METHOD:
EXCAVATE A TRENCH AROUND THE PERIMETER OF THE AREA INLET THAT IS AT LEAST 4" DEEP BY A BALE'S WIDTH WIDE. PLACE THE BALES IN THE TRENCH, MAKING SURE THAT THEY ARE BUTTED TIGHTLY. SOME BALES MAY NEED TO BE SHORTENED TO FIT INTO THE TRENCH AROUND THE AREA INLET. TWO STAKES SHOULD BE DRIVEN THROUGH EACH BALE, APPROXIMATELY 6" TO 8" IN FROM THE BALE ENDS. STAKES SHOULD BE DRIVEN AT LEAST 12" INTO THE GROUND. ONCE ALL THE BALES HAVE BEEN INSTALLED AND ANCHORED, PLACE THE EXCAVATED SOIL AGAINST THE RECEIVING SIDE OF THE BARRIER AND COMPACT IT. THE COMPACTED SOIL SHOULD BE NO MORE THAN 3" TO 4" DEEP. NOTE: WHEN A BALE AREA INLET BARRIER IS PLACED IN A SHALLOW MEDIAN DITCH, MAKE SURE THAT THE TOP OF THE BARRIER IS NOT HIGHER THAN THE PAVED ROAD. IN THIS CONFIGURATION, WATER MAY SPREAD ONTO THE ROADWAY CAUSING A HAZARDOUS CONDITION.

LIST OF COMMON PLACEMENT/INSTALLATION MISTAKES TO AVOID:
BALES SHOULD BE PLACED DIRECTLY AGAINST THE PERIMETER OF THE AREA INLET. THIS ALLOWS OVERTOPPING WATER TO FLOW DIRECTLY INTO THE INLET INSTEAD OF ONTO NEARBY SOIL CAUSING SCOUR. BALE AREA INLET BARRIERS MUST BE DUG INTO THE GROUND. BALES AT GROUND LEVEL DO NOT WORK BECAUSE THEY ALLOW WATER TO FLOW UNDER THE BARRIER.

INSPECTION AND MAINTENANCE:
BALE AREA INLET BARRIERS SHOULD BE INSPECTED EVERY 7 DAYS AND WITHIN 24 HOURS OF A RAINFALL 1/2" OR MORE. THE FOLLOWING IS A LIST OF QUESTIONS THAT SHOULD BE ADDRESSED DURING EACH INSPECTION:

- DOES WATER FLOW UNDER THE AREA INLET BARRIER?
- DOES WATER FLOW THROUGH SPACES BETWEEN ABUTTING BALES?
- ARE ANY BALES DISLODGED?
- ARE BALES DECOMPOSING DUE TO AGE AND/OR WATER DAMAGE?
- DOES SEDIMENT NEED TO BE REMOVED FROM BEHIND THE AREA INLET BARRIER?

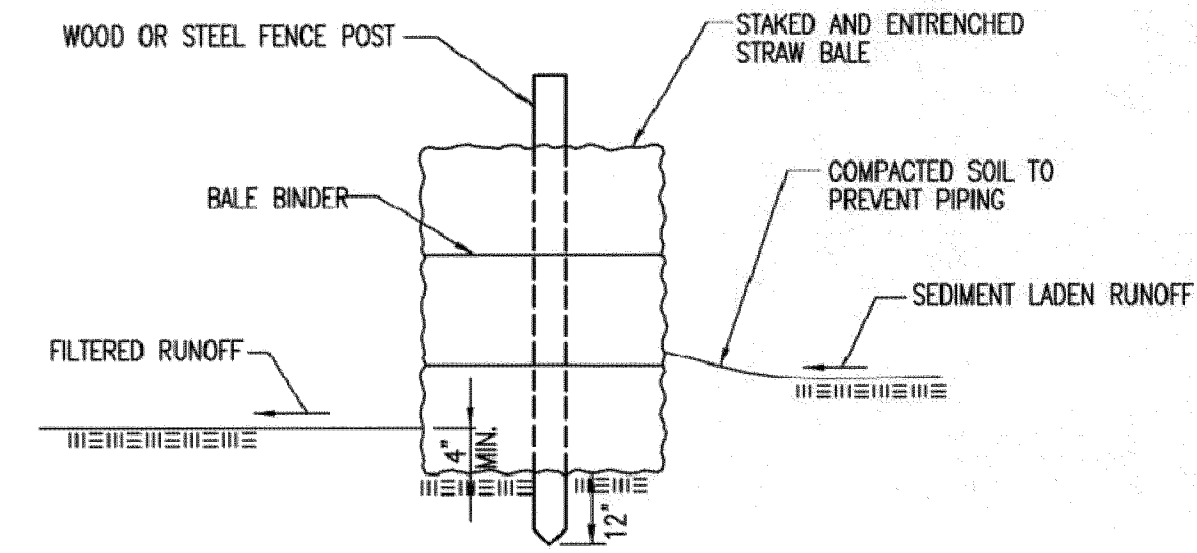

STRAW BALE BARRIERS

MATERIAL SPECIFICATION:
BALE SLOPE BARRIERS MAY BE CONSTRUCTED OF WHEAT STRAW, OAT STRAW, PRAIRIE HAY, OR BROMEGRASS HAY THAT IS FREE OF WEEDS DECLARED NOXIOUS BY THE KANSAS STATE BOARD OF AGRICULTURE. THE STAKES USED TO ANCHOR THE BALES SHOULD BE A HARDWOOD MATERIAL WITH THE FOLLOWING MINIMUM DIMENSIONS: 2" SQUARE (NOMINAL) BY 4' LONG. TWINE SHOULD BE USED TO BIND BALES. THE USE OF WIRE BINDING IS PROHIBITED BECAUSE IT DOES NOT BIODEGRADE READILY.

PLACEMENT:
A SLOPE BARRIER SHOULD BE USED AT THE TOE OF A SLOPE WHEN A DITCH DOES NOT EXIST. THE SLOPE BARRIER SHOULD BE PLACED ON NEARLY LEVEL GROUND 5' TO 10' AWAY FROM THE TOE OF A SLOPE. THE BARRIER IS PLACED AWAY FROM THE TOE OF THE SLOPE TO PROVIDE ADEQUATE STORAGE FOR SETTLING OUT SEDIMENT. WHEN PRACTICABLE, BALE SLOPE BARRIERS SHOULD BE PLACED ALONG CONTOURS TO AVOID A CONCENTRATION OF FLOW. BALE SLOPE BARRIERS CAN ALSO BE PLACED ALONG RIGHT-OF-WAY FENCE LINES TO KEEP SEDIMENT FROM CROSSING ONTO ADJACENT PROPERTY. WHEN PLACED IN THIS MANNER, THE SLOPE BARRIER WILL NOT LIKELY FOLLOW CONTOURS.

PROPER INSTALLATION METHOD:
EXCAVATE A TRENCH THE LENGTH OF THE PLANNED SLOPE BARRIER THAT IS 4" DEEP AND A BALE'S WIDTH WIDE. MAKE SURE THAT THE TRENCH IS EXCAVATED ALONG A SINGLE CONTOUR. WHEN PRACTICABLE, SLOPE BARRIERS SHOULD BE PLACED ALONG CONTOURS TO AVOID A CONCENTRATION OF FLOW. PLACE THE SOIL ON THE UPSLOPE SIDE OF THE TRENCH FOR LATER USE. PLACE THE BALES IN THE TRENCH, MAKING SURE THAT THEY ARE BUTTED TIGHTLY. TWO STAKES SHOULD BE DRIVEN THROUGH EACH BALE ALONG THE CENTERLINE OF THE DITCH CHECK, APPROXIMATELY 6" TO 8" IN FROM THE BALE ENDS. STAKES SHOULD BE DRIVEN AT LEAST 12" INTO THE GROUND. ONCE ALL THE BALES HAVE BEEN INSTALLED AND ANCHORED, PLACE THE EXCAVATED SOIL AGAINST THE UPSLOPE SIDE OF THE CHECK AND COMPACT IT. THE COMPACTED SOIL SHOULD BE NO MORE THAN 3" TO 4" DEEP.

LIST OF COMMON PLACEMENT/INSTALLATION MISTAKES TO AVOID:
WHEN PRACTICAL, DO NOT PLACE BALE SLOPE BARRIERS ACROSS CONTOURS. SLOPE BARRIERS SHOULD BE PLACED ALONG CONTOURS TO AVOID A CONCENTRATION OF FLOW. CONCENTRATED FLOW OVER A SLOPE BARRIER CREATES A SCOUR HOLE ON THE DOWNSLOPE SIDE OF THE BARRIER. THE SCOUR HOLE EVENTUALLY UNDERMINES THE BALES AND THE BARRIER FAILS. DO NOT PLACE BALE SLOPE BARRIERS IN AREAS WITH SHALLOW SOILS UNDERLAIN BY ROCK. IF THE BARRIER IS NOT ANCHORED SUFFICIENTLY, IT WILL WASH OUT. BALE SLOPE BARRIERS MUST BE DUG INTO THE GROUND. BALES AT GROUND LEVEL DO NOT WORK BECAUSE THEY ALLOW WATER TO FLOW UNDER THE BARRIER.

INSPECTION AND MAINTENANCE:
BALE SLOPE BARRIERS SHOULD BE INSPECTED EVERY 7 DAYS AND WITHIN 24 HOURS OF A RAINFALL OF 1/2" OR MORE. THE FOLLOWING IS A LIST OF QUESTIONS THAT SHOULD BE ADDRESSED DURING EACH INSPECTION:

- ARE THERE ANY POINTS ALONG THE SLOPE BARRIER WHERE WATER IS CONCENTRATING?
- DOES WATER FLOW UNDER THE SLOPE BARRIER?
- DOES WATER FLOW THROUGH SPACES BETWEEN ABUTTING BALES?
- ARE ANY BALES DISLODGED?
- ARE BALES DECOMPOSING DUE TO AGE AND/OR WATER DAMAGE?
- DOES SEDIMENT NEED TO BE REMOVED FROM BEHIND THE SLOPE BARRIER?

REVISION DATE: MAY 2013

<p>CITY OF WICHITA PUBLIC WORKS & UTILITIES ENGINEERING DIVISION</p>		<p>STRAW BALE DITCH CHECK AND BARRIER DETAILS</p>	
		<p>CITY ENGINEER GARY JANZEN, P.E.</p>	
PROJECT NUMBER	OCA NUMBER	DATE	
CITY ENGINEER'S OFFICE		SHEET	
<p>CITY HALL - SEVENTH FLOOR 455 NORTH MAIN STREET WICHITA, KANSAS 67202-1620 (316) 268-4301</p>			

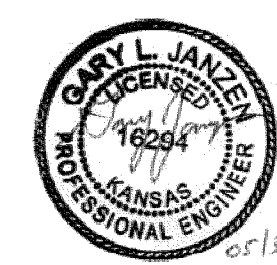

SW-503

NO.	BY	DATE	REVISION
3.	JWO	MES 3/10/16	AS PER CITY COMMENTS
2.	JWO	MES 10/09/16	AS PER CITY COMMENTS
1.	JWO	MES 3/02/16	AS PER CITY COMMENTS
			ORIGINAL SUBMITTAL

Renaissance Infrastructure Consulting
913.317.9500
WWW.RIC-CONSULT.COM
1138 W. CARBIDE CIRCLE DRIVE
KANSAS CITY, KANSAS 64103

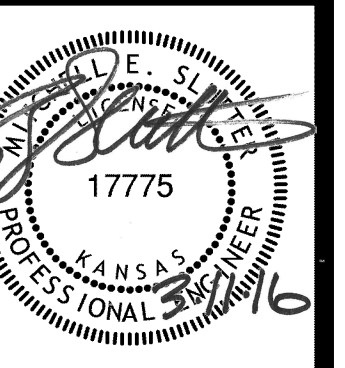

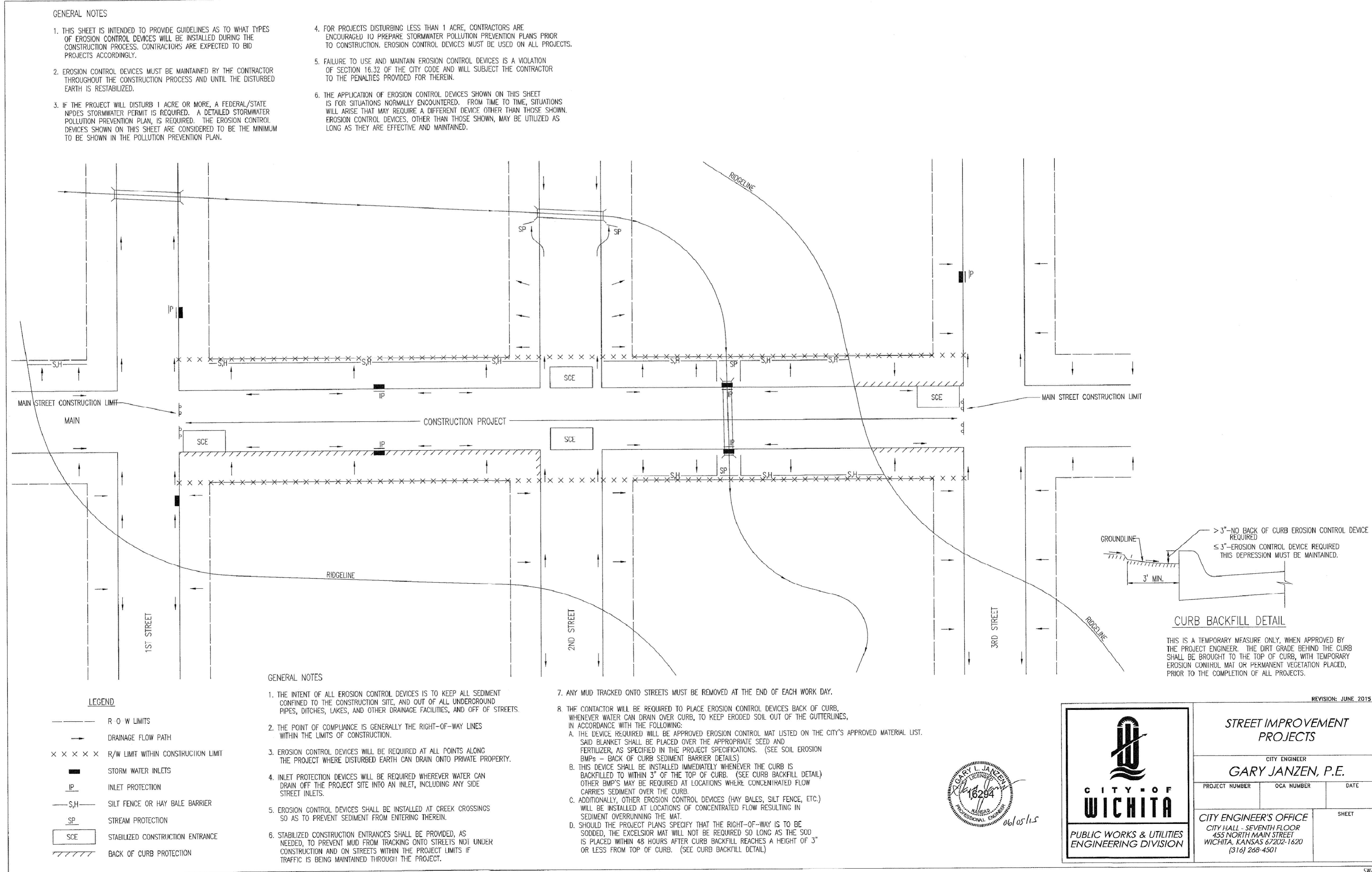

- GENERAL NOTES**
- THIS SHEET IS INTENDED TO PROVIDE GUIDELINES AS TO WHAT TYPES OF EROSION CONTROL DEVICES WILL BE INSTALLED DURING THE CONSTRUCTION PROCESS. CONTRACTORS ARE EXPECTED TO BID PROJECTS ACCORDINGLY.
 - EROSION CONTROL DEVICES MUST BE MAINTAINED BY THE CONTRACTOR THROUGHOUT THE CONSTRUCTION PROCESS AND UNTIL THE DISTURBED EARTH IS RESTABILIZED.
 - IF THE PROJECT WILL DISTURB 1 ACRE OR MORE, A FEDERAL/STATE NPDES STORMWATER PERMIT IS REQUIRED. A DETAILED STORMWATER POLLUTION PREVENTION PLAN, IS REQUIRED. THE EROSION CONTROL DEVICES SHOWN ON THIS SHEET ARE CONSIDERED TO BE THE MINIMUM TO BE SHOWN IN THE POLLUTION PREVENTION PLAN.
 - FOR PROJECTS DISTURBING LESS THAN 1 ACRE, CONTRACTORS ARE ENCOURAGED TO PREPARE STORMWATER POLLUTION PREVENTION PLANS PRIOR TO CONSTRUCTION. EROSION CONTROL DEVICES MUST BE USED ON ALL PROJECTS.
 - FAILURE TO USE AND MAINTAIN EROSION CONTROL DEVICES IS A VIOLATION OF SECTION 16.32 OF THE CITY CODE AND WILL SUBJECT THE CONTRACTOR TO THE PENALTIES PROVIDED FOR THEREIN.
 - THE APPLICATION OF EROSION CONTROL DEVICES SHOWN ON THIS SHEET IS FOR SITUATIONS NORMALLY ENCOUNTERED. FROM TIME TO TIME, SITUATIONS WILL ARISE THAT MAY REQUIRE A DIFFERENT DEVICE OTHER THAN THOSE SHOWN. EROSION CONTROL DEVICES, OTHER THAN THOSE SHOWN, MAY BE UTILIZED AS LONG AS THEY ARE EFFECTIVE AND MAINTAINED.

- LEGEND**
- R O W LIMITS
 - DRAINAGE FLOW PATH
 - x x x x x R/W LIMIT WITHIN CONSTRUCTION LIMIT
 - STORM WATER INLETS
 - IP INLET PROTECTION
 - S.H SILT FENCE OR HAY BALE BARRIER
 - SP STREAM PROTECTION
 - SCE STABILIZED CONSTRUCTION ENTRANCE
 - /// BACK OF CURB PROTECTION

- GENERAL NOTES**
- THE INTENT OF ALL EROSION CONTROL DEVICES IS TO KEEP ALL SEDIMENT CONFINED TO THE CONSTRUCTION SITE, AND OUT OF ALL UNDERGROUND PIPES, DITCHES, LAKES, AND OTHER DRAINAGE FACILITIES, AND OFF OF STREETS.
 - THE POINT OF COMPLIANCE IS GENERALLY THE RIGHT-OF-WAY LINES WITHIN THE LIMITS OF CONSTRUCTION.
 - EROSION CONTROL DEVICES WILL BE REQUIRED AT ALL POINTS ALONG THE PROJECT WHERE DISTURBED EARTH CAN DRAIN ONTO PRIVATE PROPERTY.
 - INLET PROTECTION DEVICES WILL BE REQUIRED WHEREVER WATER CAN DRAIN OFF THE PROJECT SITE INTO AN INLET, INCLUDING ANY SIDE STREET INLETS.
 - EROSION CONTROL DEVICES SHALL BE INSTALLED AT CREEK CROSSINGS SO AS TO PREVENT SEDIMENT FROM ENTERING THEREIN.
 - STABILIZED CONSTRUCTION ENTRANCES SHALL BE PROVIDED, AS NEEDED, TO PREVENT MUD FROM TRACKING ONTO STREETS NOT UNDER CONSTRUCTION AND ON STREETS WITHIN THE PROJECT LIMITS IF TRAFFIC IS BEING MAINTAINED THROUGH THE PROJECT.
 - ANY MUD TRACKED ONTO STREETS MUST BE REMOVED AT THE END OF EACH WORK DAY.
 - THE CONTRACTOR WILL BE REQUIRED TO PLACE EROSION CONTROL DEVICES BACK OF CURB, WHENEVER WATER CAN DRAIN OVER CURB, TO KEEP ERODED SOIL OUT OF THE GUTTERLINES, IN ACCORDANCE WITH THE FOLLOWING:
 - THE DEVICE REQUIRED WILL BE APPROVED EROSION CONTROL MAT LISTED ON THE CITY'S APPROVED MATERIAL LIST. SAID BLANKET SHALL BE PLACED OVER THE APPROPRIATE SEED AND FERTILIZER, AS SPECIFIED IN THE PROJECT SPECIFICATIONS. (SEE SOIL EROSION BMPs - BACK OF CURB SEDIMENT BARRIER DETAILS)
 - THIS DEVICE SHALL BE INSTALLED IMMEDIATELY WHENEVER THE CURB IS BACKFILLED TO WITHIN 3" OF THE TOP OF CURB. (SEE CURB BACKFILL DETAIL) OTHER BMPs MAY BE REQUIRED AT LOCATIONS WHERE CONCENTRATED FLOW CARRIES SEDIMENT OVER THE CURB.
 - ADDITIONALLY, OTHER EROSION CONTROL DEVICES (HAY BALES, SILT FENCE, ETC.) WILL BE INSTALLED AT LOCATIONS OF CONCENTRATED FLOW RESULTING IN SEDIMENT OVERRUNNING THE MAT.
 - SHOULD THE PROJECT PLANS SPECIFY THAT THE RIGHT-OF-WAY IS TO BE SODDED, THE EXCELSIOR MAT WILL NOT BE REQUIRED SO LONG AS THE SOU IS PLACED WITHIN 48 HOURS AFTER CURB BACKFILL REACHES A HEIGHT OF 3" OR LESS FROM TOP OF CURB. (SEE CURB BACKFILL DETAIL)

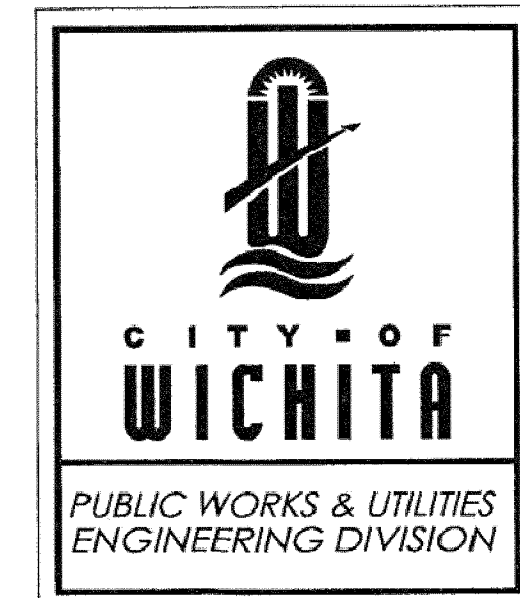

REVISION: JUNE 2015

STREET IMPROVEMENT PROJECTS

CITY ENGINEER
GARY JANZEN, P.E.

PROJECT NUMBER	OCA NUMBER	DATE

CITY ENGINEER'S OFFICE
CITY HALL - SEVENTH FLOOR
455 NORTH MAIN STREET
WICHITA, KANSAS 67202-1620
(316) 268-4501

SHEET

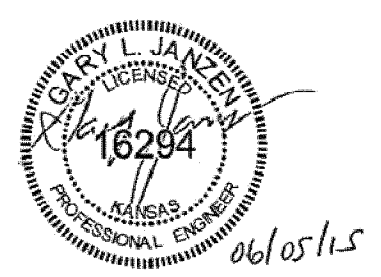

NO.	BY	DATE	REVISION
3.	JWO	MES 3/10/16	AS PER CITY COMMENTS
2.	JWO	MES 13/09/16	AS PER CITY COMMENTS
1.	JWO	MES 3/02/16	AS PER CITY COMMENTS
			ORIGINAL SUBMITTAL

Renaissance Infrastructure Consulting

913.317.9500
WWW.RIC-CONSULT.COM

1138 W. CARBIDE CIRCLE DRIVE
KANSAS CITY, KANSAS 64103

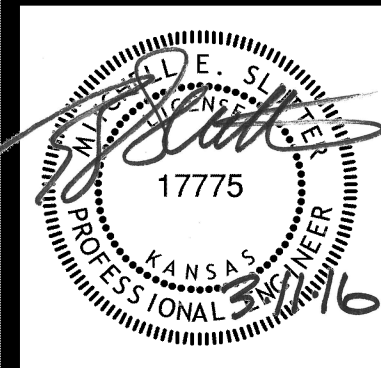

PHASE 1 - INITIAL EARTHWORK AND UTILITIES (EXCEPT STORM SEWER)

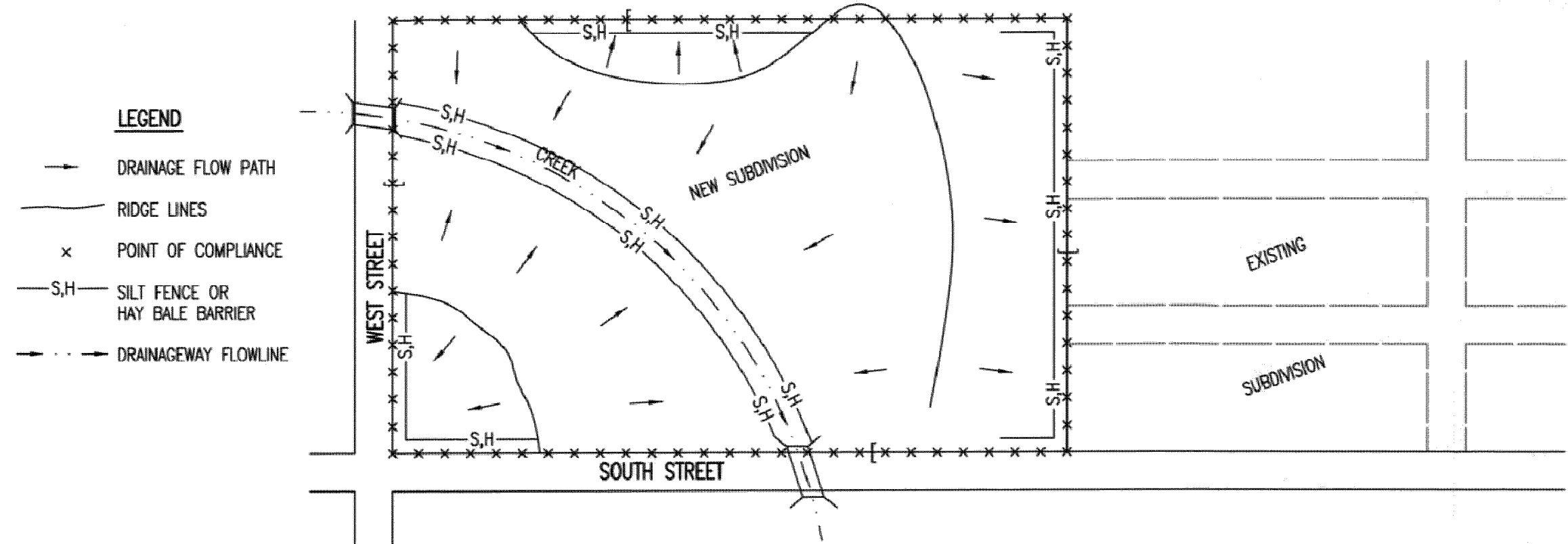

- DURING THIS PHASE OF SUBDIVISION CONSTRUCTION, THE POINTS OF COMPLIANCE ARE THE PERIMETER BOUNDARIES AND ANY DRAINAGE WAYS OR STORM SEWERS DRAINING THROUGH OR FROM THE SITE. SHOULD LAKES BE CONSTRUCTED WITHIN THE SUBDIVISION THAT WILL DISCHARGE DURING STORMS, THEY ARE ALSO A POINT OF COMPLIANCE.
- HAY BALES OR SILT FENCE MUST BE CONSTRUCTED ALONG THE PROPERTY LINE WHERE ON SITE WATER CAN DRAIN OFF THE PROPERTY. THESE EROSION CONTROL DEVICES WILL ALSO BE INSTALLED ALONG ANY DRAINAGE DITCH OR LAKE THAT CAN DISCHARGE.
- SHOULD SILT OR SEDIMENT ENTER THE DITCHES OR STREETS ON THE ADJACENT BOUNDARY STREETS, APPROPRIATE EROSION CONTROL DEVICES WILL BE PLACED WITHIN THE SUBDIVISION TO PREVENT THIS.
- ANY MUD TRACKED ONTO ADJACENT STREETS WILL BE REMOVED WITHIN 48 HOURS OR BY FRIDAY AT 6:00 PM, WHICHEVER IS EARLIER.
- CONTRACTORS WORKING WITHIN THE SITE WILL NOT BE REQUIRED TO USE INDIVIDUAL EROSION CONTROL DEVICES AS LONG AS THOSE SPECIFIED ABOVE ARE IN PLACE AND EFFECTIVE. CONTRACTORS WORKING ON THE BOUNDARY LINE STREETS OR ON ADJACENT PROPERTIES TO EXTEND UTILITIES ARE EXPECTED TO USE EROSION CONTROL DEVICES AT THEIR WORK LOCATIONS, AS NEEDED.
- UTILIZE STABILIZED CONSTRUCTION ENTRANCE AT ENTRANCE AND EXIT ONTO ANY EXISTING PUBLIC STREETS.
- IF THE INITIAL EARTH WORK AND UTILITIES ARE DONE AS PART OF A PUBLIC IMPROVEMENT PROJECT, THESE EROSION CONTROL DEVICES WILL BE INSTALLED BY THE CONTRACTOR AS SPECIFIED IN THE INDIVIDUAL PROJECT CONTRACTS. THE CONTRACTOR WILL MAINTAIN THE DEVICES UNTIL COMPLETION OF THE CONTRACT, AT WHICH TIME THE DEVELOPER WILL ASSUME MAINTENANCE RESPONSIBILITIES. IF THESE CONTRACTS ARE NOT PUBLIC IMPROVEMENT PROJECTS, THE DEVELOPER WILL BE RESPONSIBLE FOR INSTALLING AND MAINTAINING THESE DEVICES.
- WITHIN 14 DAYS OF COMPLETION OF EARTHWORK ACTIVITIES IN ANY GIVEN AREA, THAT AREA SHALL BE TEMPORARILY OR PERMANENTLY SEEDED AND MULCHED.

PHASE 3 - STREET CONSTRUCTION

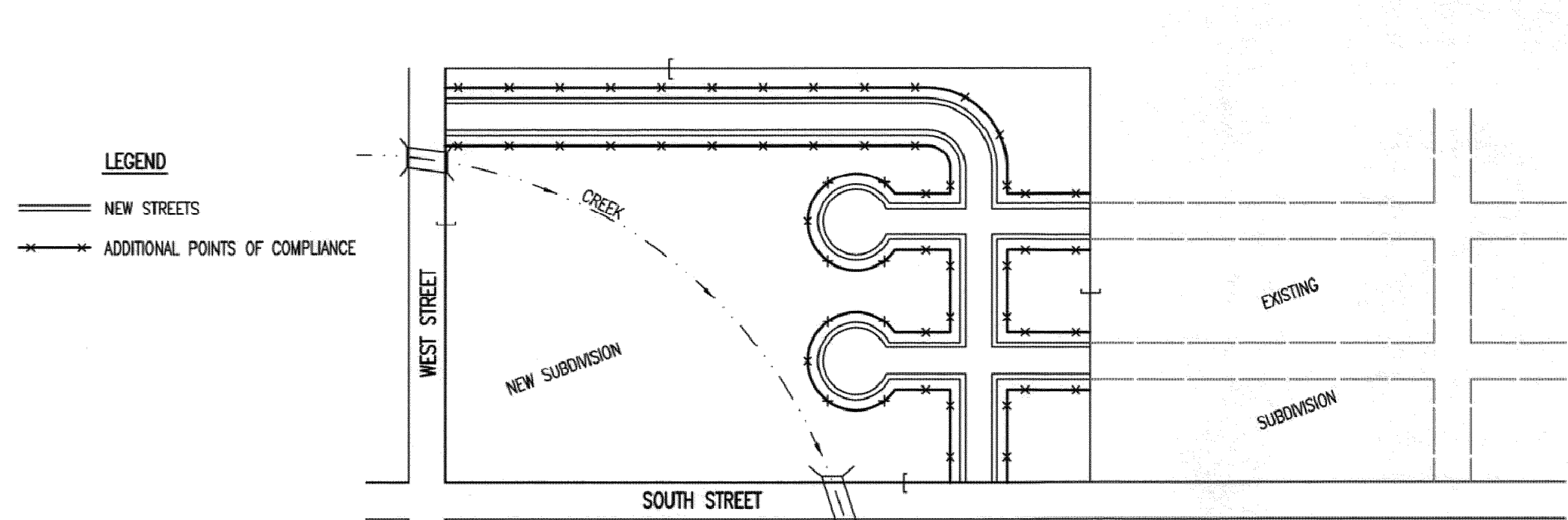

- DURING THIS PHASE OF SUBDIVISION CONSTRUCTION, NEW STREETS ARE INSTALLED. ALL EROSION CONTROL DEVICES INSTALLED DURING PHASE 1 AND 2 MUST STILL BE MAINTAINED. THE POINT OF COMPLIANCE NOW SHIFTS TO THE BACK OF CURB ALONG EACH STREET.
- CURB OPENING INLET PROTECTION:
 - SUMP AREAS - INLET PROTECTION SHALL BE PROVIDED WHEN STREET SUBGRADE WORK IS COMPLETED.
 - NON-SUMP LOCATIONS - PROVIDE INLET PROTECTION AS SOON AS BASE COURSE ASPHALT IS INSTALLED, BEFORE THE SURFACE COURSE LIFT.
- EROSION CONTROL DEVICES WILL BE REQUIRED BACK OF CURB WHEREVER WATER CAN FLOW OVER THE CURB AND THE CURB HAS BEEN BACKFILLED TO WITHIN 3" OR LESS OF THE TOP OF CURB (SEE CURB BACKFILL DETAIL). FOR CURBS NOT YET ENTIRELY BACKFILLED (3" OR MORE BELOW TOP OF CURB), ADDITIONAL DEVICES WILL BE REQUIRED AT POINTS WHERE WATER BREAKS OVER CURB WHICH COULD RESULT IN THE PLACEMENT OF SEDIMENT IN THE GUTTER.
- SEE DETAIL SHEET FOR BACK OF CURB PROTECTION.
- THE BACK OF CURB PROTECTION SPECIFIED ON THIS PLAN MAY HAVE TO BE SUPPLEMENTED WITH HAY BALE OR SILT FENCE EROSION CONTROL DEVICES AT LOCATIONS WHERE CONCENTRATED FLOW RESULTS IN SEDIMENT BEING CARRIED OVER THE EXCELSIOR MATS.
- THE STREET CONTRACTOR WILL BE RESPONSIBLE FOR INSTALLING BACK OF CURB EROSION CONTROL DEVICES.
- THE INDIVIDUAL LOT OWNERS WILL BE RESPONSIBLE FOR MAINTAINING THE BACK OF CURB EROSION CONTROL DEVICES IN FRONT OF THEIR LOTS UNTIL SUCH TIME AS ADJACENT DISTURBED EARTH IS STABILIZED WITH GRASS OR SOD.

PHASE 2 - INSTALLATION OF STORM SEWER

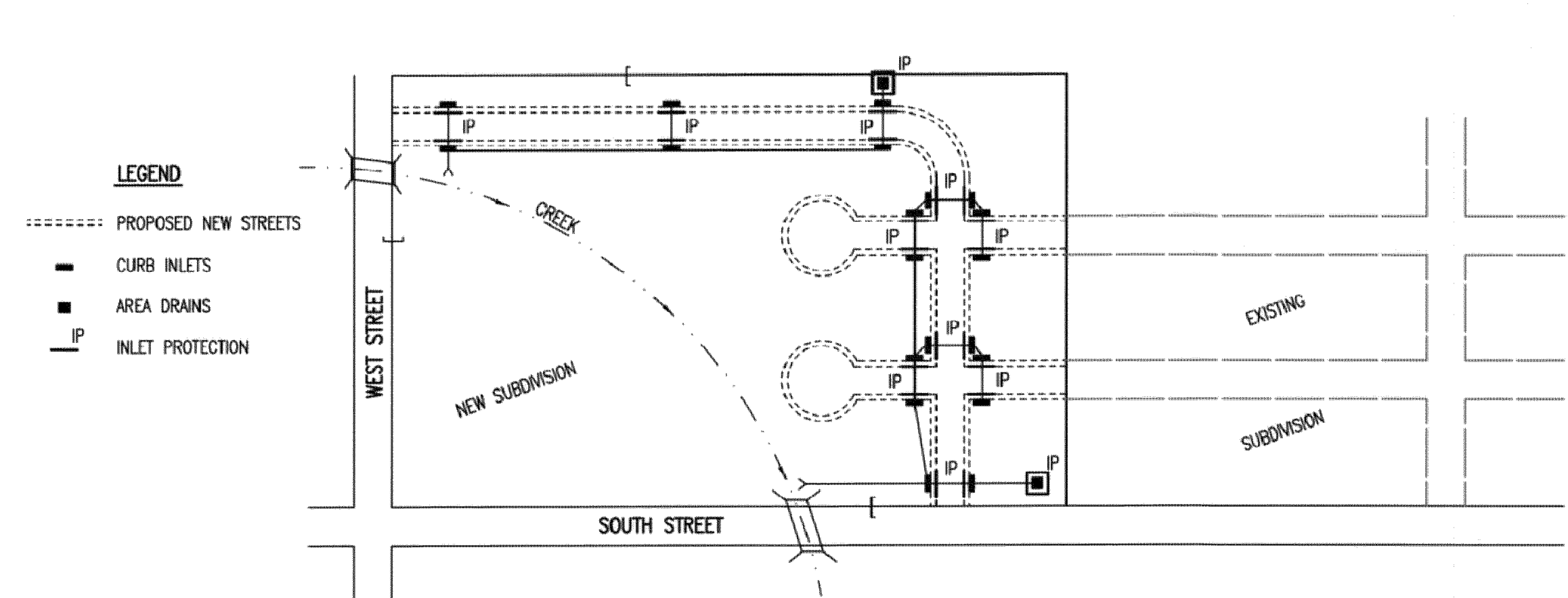

- DURING THIS PHASE OF SUBDIVISION DEVELOPMENT, ALL EROSION CONTROL DEVICES REQUIRED IN PHASE 1 SHALL REMAIN IN PLACE AND BE MAINTAINED.
- AS NEW STORM SEWERS, WITH INLETS, ARE INSTALLED, THE STORM SEWERS MUST NOW BE PROTECTED SO ALL NEW INLETS BECOME POINTS OF COMPLIANCE.
- AREA DRAINS - AS SOON AS WATER CAN FLOW INTO THESE DRAINS, HAY BALE OR SILT FENCE PROTECTION WILL BE INSTALLED AROUND THEM.
- CURB OPENING INLETS - AS SOON AS WATER CAN FLOW INTO THESE DRAINS, INLET PROTECTION DEVICES MUST BE INSTALLED. IF WATER CANNOT FLOW INTO CURB INLETS UNTIL STREET CONSTRUCTION IS COMPLETE, THEN STREET CONTRACTOR WILL INSTALL INLET PROTECTION. SEE PHASE 3 - STREET CONSTRUCTION.
- THE STORM SEWER CONTRACTOR WILL BE RESPONSIBLE FOR INSTALLING THESE DEVICES.
- THE SUBDIVISION DEVELOPER WILL MAINTAIN THESE EROSION CONTROL DEVICES ONCE INSTALLED.
- ALL DISTURBED GROUND WILL BE FINAL GRADED AND TEMPORARILY OR PERMANENTLY SEEDED WITHIN 14 DAYS IF COMPLETION OF WORK IN ANY GIVEN PART OF THE SUBDIVISION.
- ONCE ALL DISTURBED GROUND DRAINING TO AN INLET HAS BEEN RESTABILIZED WITH GRASS OR SOD, THE SUBDIVISION DEVELOPER WILL BE RESPONSIBLE FOR PERMANENTLY REMOVING THE INLET PROTECTION.

GENERAL NOTES

- THE INTENT OF ALL EROSION CONTROL DEVICES IS TO PREVENT ERODED SOIL FROM ENTERING DITCHES, STORM SEWERS, LAKES, STREETS OR ANY OTHER OTHER DRAINAGE FEATURE.
- THIS SHEET IS INTENDED TO PROVIDE GUIDELINES AS TO WHAT TYPE OF EROSION CONTROL DEVICES WILL BE INSTALLED DURING THE CONSTRUCTION PROCESS. CONTRACTORS ARE EXPECTED TO BID PROJECTS ACCORDINGLY.
- EROSION CONTROL DEVICES SHALL BE MAINTAINED DURING THE CONSTRUCTION PROCESS TO REMAIN EFFECTIVE. MAINTENANCE SHALL BE AS INDICATED ON SOIL EROSION BMP'S DETAIL SHEETS.
- PERSONS DESTROYING EROSION CONTROL DEVICES SHALL BE RESPONSIBLE FOR IMMEDIATELY REPAIRING THEM OR INSTALLING SUITABLE REPLACEMENT DEVICES.
- THE DEVELOPMENT OF ANY SUBDIVISION THAT DISTURBS 1 ACRE OR MORE WILL REQUIRE A FEDERAL/STATE NPDES STORMWATER PERMIT. THE PREPARATION OF A STORMWATER POLLUTION PREVENTION PLAN IS REQUIRED. EROSION CONTROL DEVICES ARE REQUIRED. THE DETAILS SHOWN ON THIS SHEET ARE THE MINIMUM STANDARDS TO BE SHOWN ON POLLUTION PREVENTION PLANS.
- FOR SUBDIVISIONS SMALLER THAN 1 ACRE, SOIL EROSION DEVICES ARE REQUIRED. ALSO, DEVELOPERS AND CONTRACTORS ARE ENCOURAGED TO DEVELOP POLLUTION PREVENTION PLANS FOR EACH PROJECT PRIOR TO CONSTRUCTION.
- FAILURE TO USE AND MAINTAIN SOIL EROSION DEVICES IS A VIOLATION OF SECTION 16.32 OF THE CITY CODE AND WILL SUBJECT THE SUBDIVISION DEVELOPER AND CONTRACTORS TO THE PENALTIES PROVIDED THEREIN.
- THE APPLICATION OF EROSION CONTROL DEVICES SHOWN ON THIS SHEET IS FOR SITUATIONS NORMALLY ENCOUNTERED. FROM TIME TO TIME, SITUATIONS WILL ARISE THAT MAY REQUIRE DEVICES OTHER THAN THOSE SHOWN. EROSION CONTROL DEVICES, OTHER THAN THOSE SHOWN, MAY BE UTILIZED SO LONG AS THEY ARE EFFECTIVE AND MAINTAINED.
- A STABILIZED EARTH SURFACE IS DEFINED AS ONE THAT IS HARD SURFACED WITH CONCRETE, ASPHALT, OR THE LIKE, OR ONE ON WHICH 70% OF THE GRASS HAS GERMINATED ON THE ENTIRE SURFACE.

SEE DETAIL SHEET FOR BACK OF CURB PROTECTION DETAIL

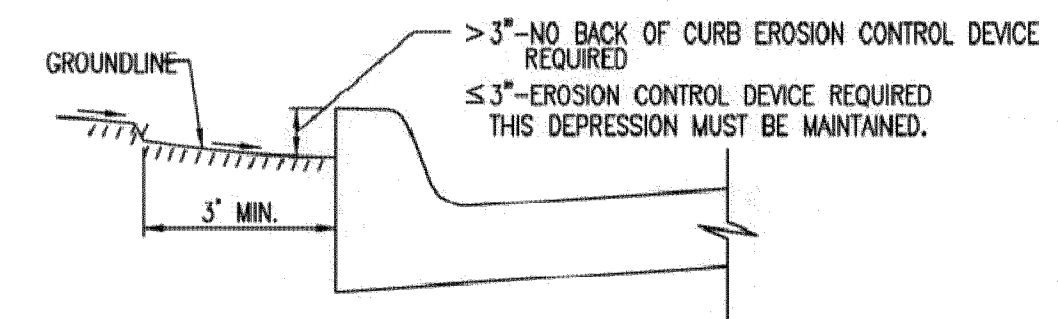

CURB BACKFILL DETAIL (STREET CONSTRUCTION ONLY)

THIS IS A TEMPORARY MEASURE ONLY, WHEN APPROVED BY THE PROJECT ENGINEER. THE DIRT GRADE BEHIND THE CURB SHALL BE BROUGHT TO THE TOP OF CURB, WITH TEMPORARY EROSION CONTROL MAT OR PERMANENT VEGETATION PLACED, PRIOR TO THE COMPLETION OF ALL PROJECTS.

REVISION DATE: MAY 2013

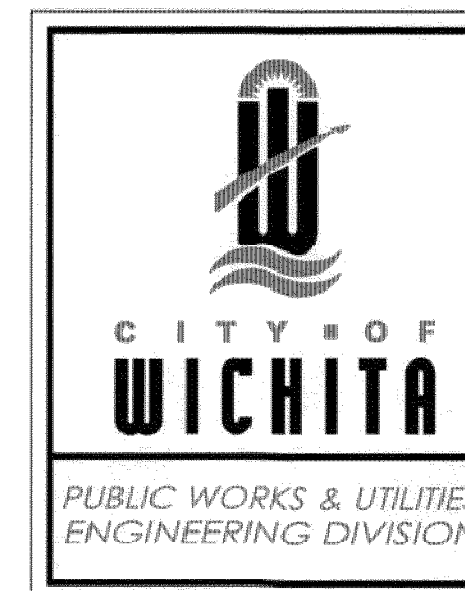
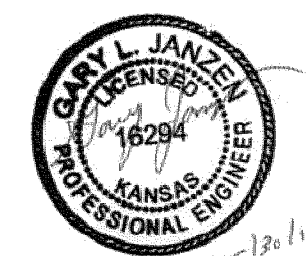

SUBDIVISION DEVELOPMENT PROCESS		
CITY ENGINEER		
GARY JANZEN, P.E.		
PROJECT NUMBER	CCA NUMBER	DATE
CITY ENGINEER'S OFFICE	SHEET	
CITY HALL - SEVENTH FLOOR 455 NORTH MAIN STREET WICHITA, KANSAS 67202-1620 (316) 268-4501		

NO.	BY	DATE	REVISION
3.	JWO	MES 3/10/16	AS PER CITY COMMENTS
2.	JWO	MES 13/09/16	AS PER CITY COMMENTS
1.	JWO	MES 3/02/16	AS PER CITY COMMENTS
			ORIGINAL SUBMITTAL

Renaissance Infrastructure Consulting
913.317.9500
WWW.RIC-CONSULT.COM
1138 W. CARBRIDGE CIRCLE DRIVE
KANSAS CITY, KANSAS 66103

