

CLAY LINER CONSTRUCTION PROCEDURE FOR POND SEALING

* THE TRENCH ZONE INDICATED SHALL BE BACKFILLED ENTIRELY WITH CLAY MATERIAL MEETING THE SAME REQUIREMENTS AS POND LINING. NO GRANULAR BACKFILL WILL BE ALLOWED IN THIS AREA, EXCEPT THAT THE TOP 4" OF BACKFILL SHALL BE ON-SITE TOPSOIL. ANY COSTS ASSOCIATED WITH THIS WORK SHALL BE SUBSIDIARY TO THE PRICE BID FOR 30" RCP

RIPRAP PLAN
(SWS Line No. 1)

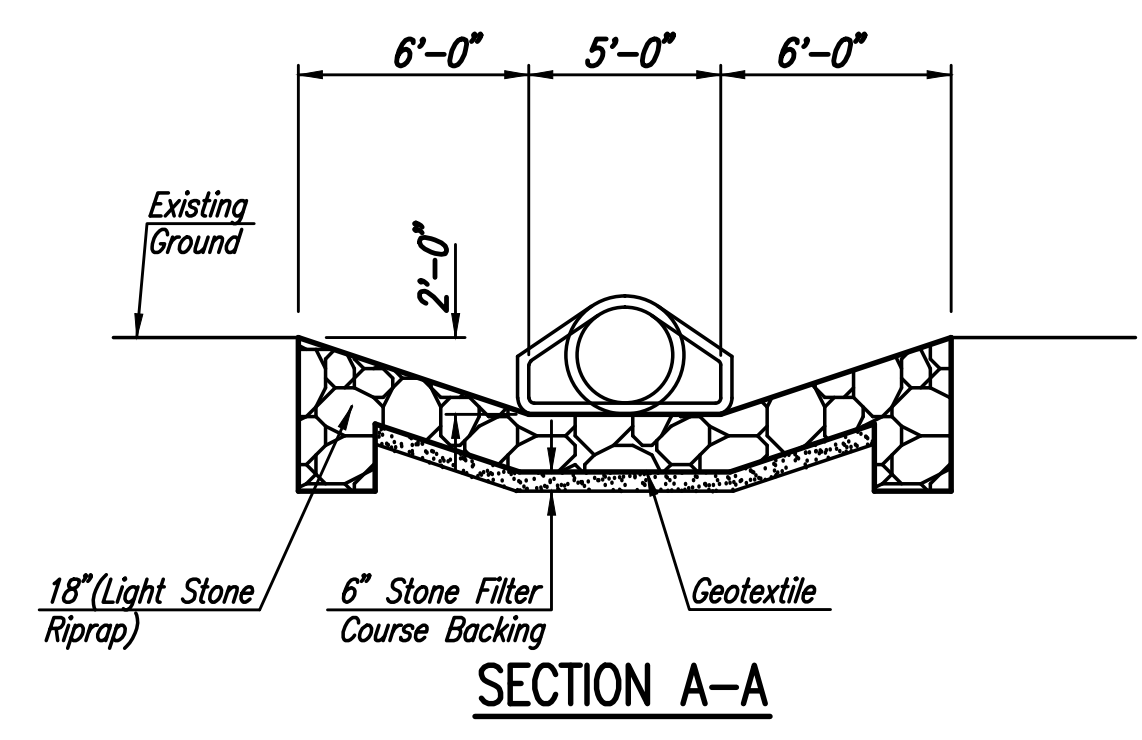

SECTION A-A

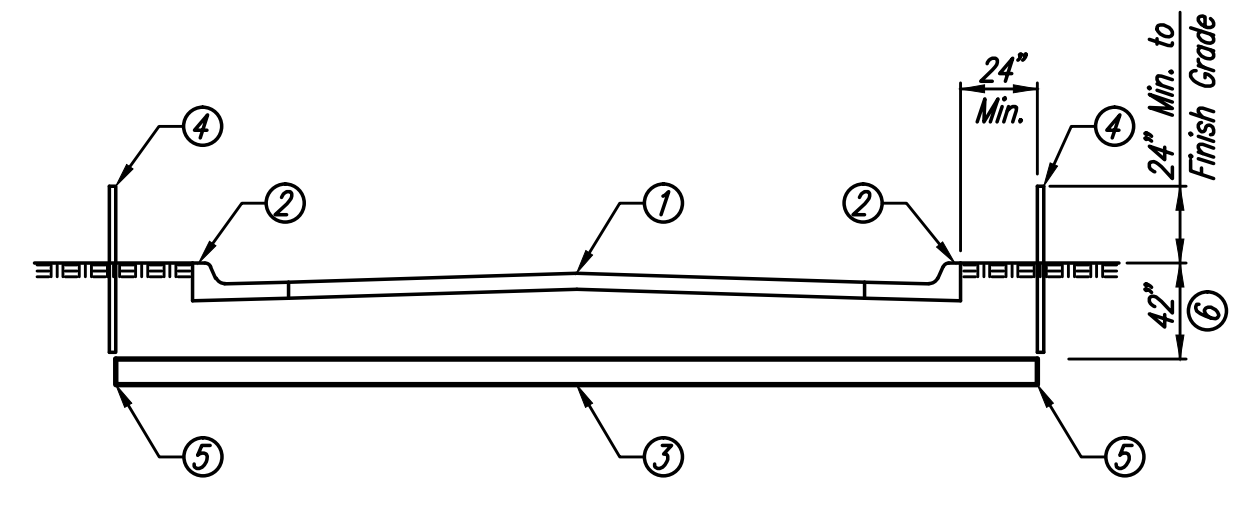

CLASS SDR 21 SLEEVES

Payment for "Irrigation Sleeves" Shall be Per Linear Foot, and Shall include Items 2 thru 5 Listed Below.

- ① Pavement/Street
- ② Permanent Mark on Top of Curb, Stamped in Wet Concrete—"x" or "s"
- ③ 4" Class SDR 21 Sleeve Extended 2' Past Back of Curbs. Sleeves Shall be Bedded and Backfilled in Accordance with City of Wichita Specifications for Flexible Sanitary/Storm Sewer Pipe.
- ④ Temporary T-Post Marker, Until Permanent Benchmark is Made in Concrete (2 Total)
- ⑤ 4" PVC Caps-Not Glued (2 Total)
- ⑥ Adjust Depth Where Necessary to Avoid Other Utilities.

Sowed 07-19-2016 3:10:42 PM by BJS
 Plot Scale 1:1 07-20-2016 3:27:43 PM by BJS
 U:\Wichita-civil\2015\15631\000\Misc\Drawings\15631-000-24C-MISCELLANEOUS DRAINAGE DETAILS

	No.	Revision	By	Date
	FONTANA 5TH-PHASE 1 PAVING AND INCIDENTAL DRAINAGE IMPROVEMENTS MISCELLANEOUS DRAINAGE DETAILS			
	GARY JANZEN, P.E. - CITY ENGINEER CITY OF WICHITA PROJECT NO. 472-84801			
	PROFESSIONAL ENGINEERING CONSULTANTS, P.A. 303 SOUTH TOPEKA WICHITA, KS 67202 316-262-2691 www.pec1.com			
Designed by	BMM	Job No.	31-15631-000	Sht. 24 of 42
Drawn by	BJS	Date	July 2016	