

EXPANSION JOINT (E.J.)

NOTE: Extra Thickness to be Subsidiary to Price of Square Yards Pavement

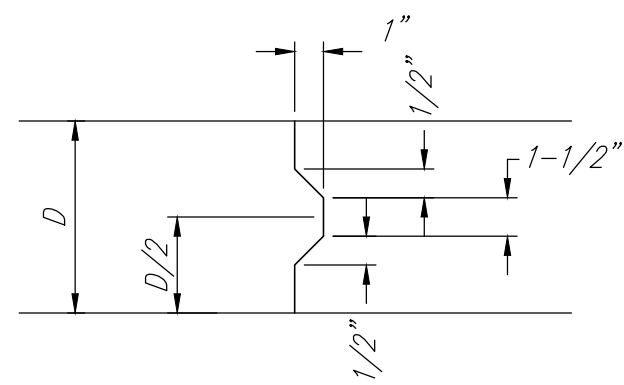

KEYWAY DETAIL

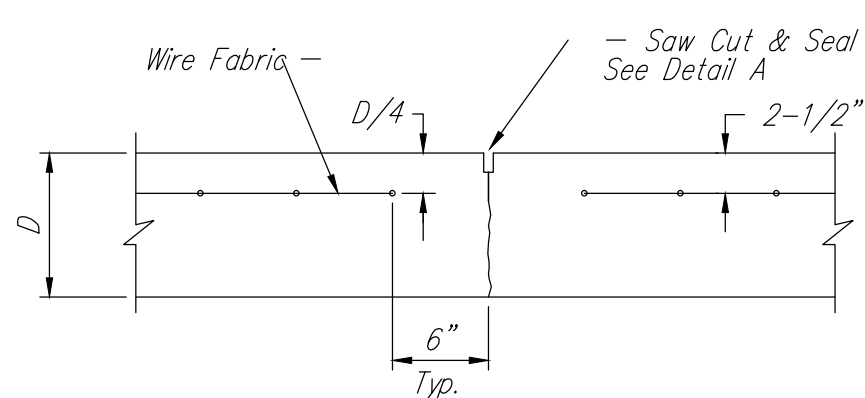

CONTRACTION JOINT DETAIL (C.J.)

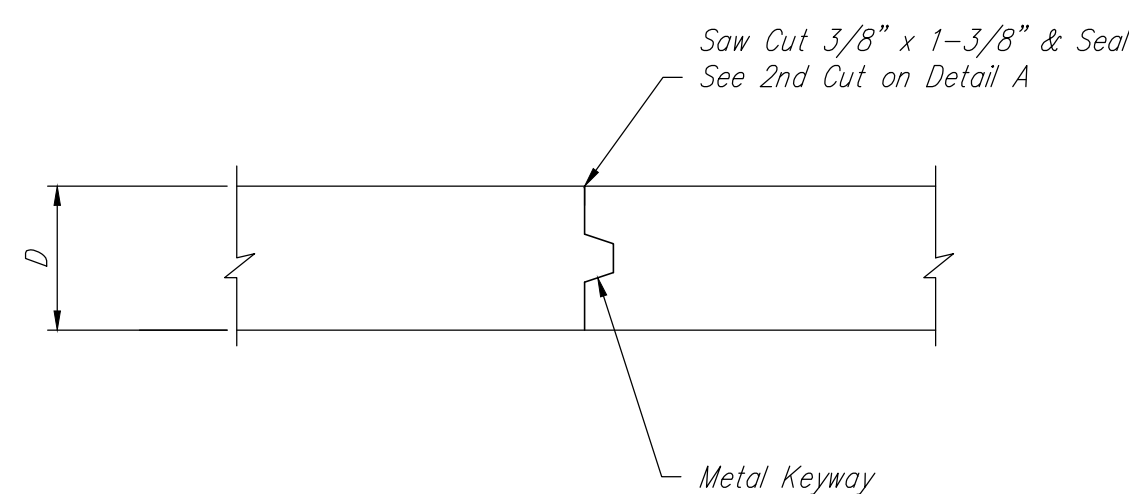

LONGITUDINAL JOINT DETAIL (L.J.) "A"

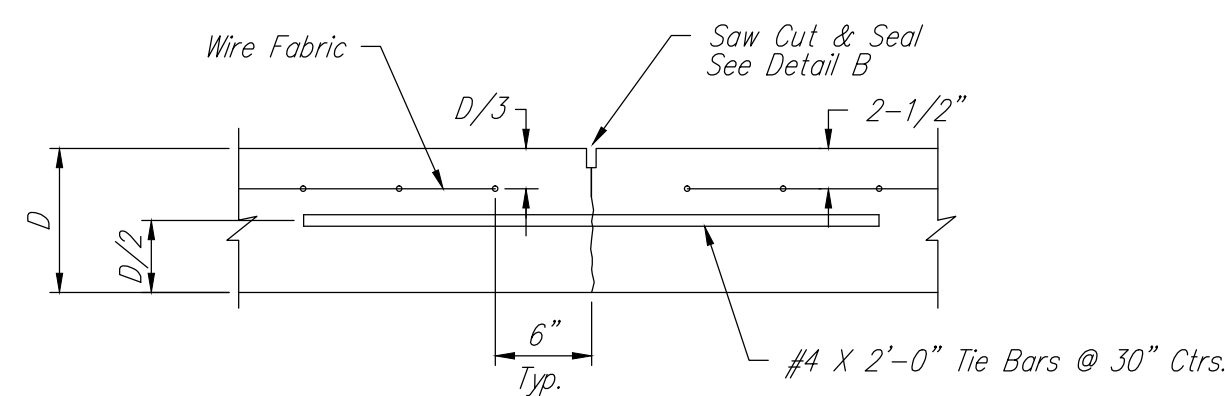

LONGITUDINAL JOINT DETAIL (L.J.)

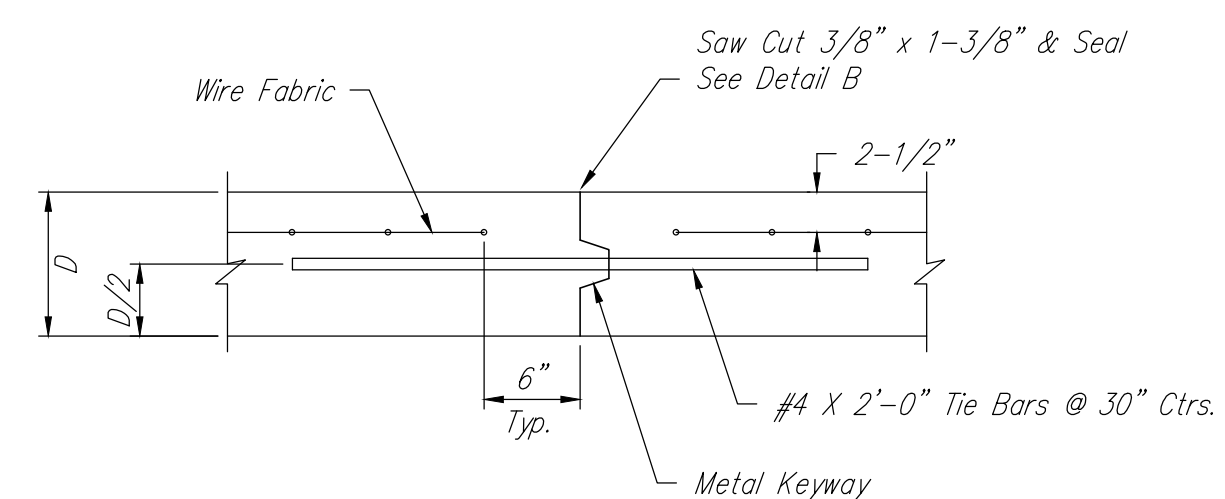

OPTIONAL LONGITUDINAL JOINT DETAIL (L.J.) (CONSTRUCTION JOINT)

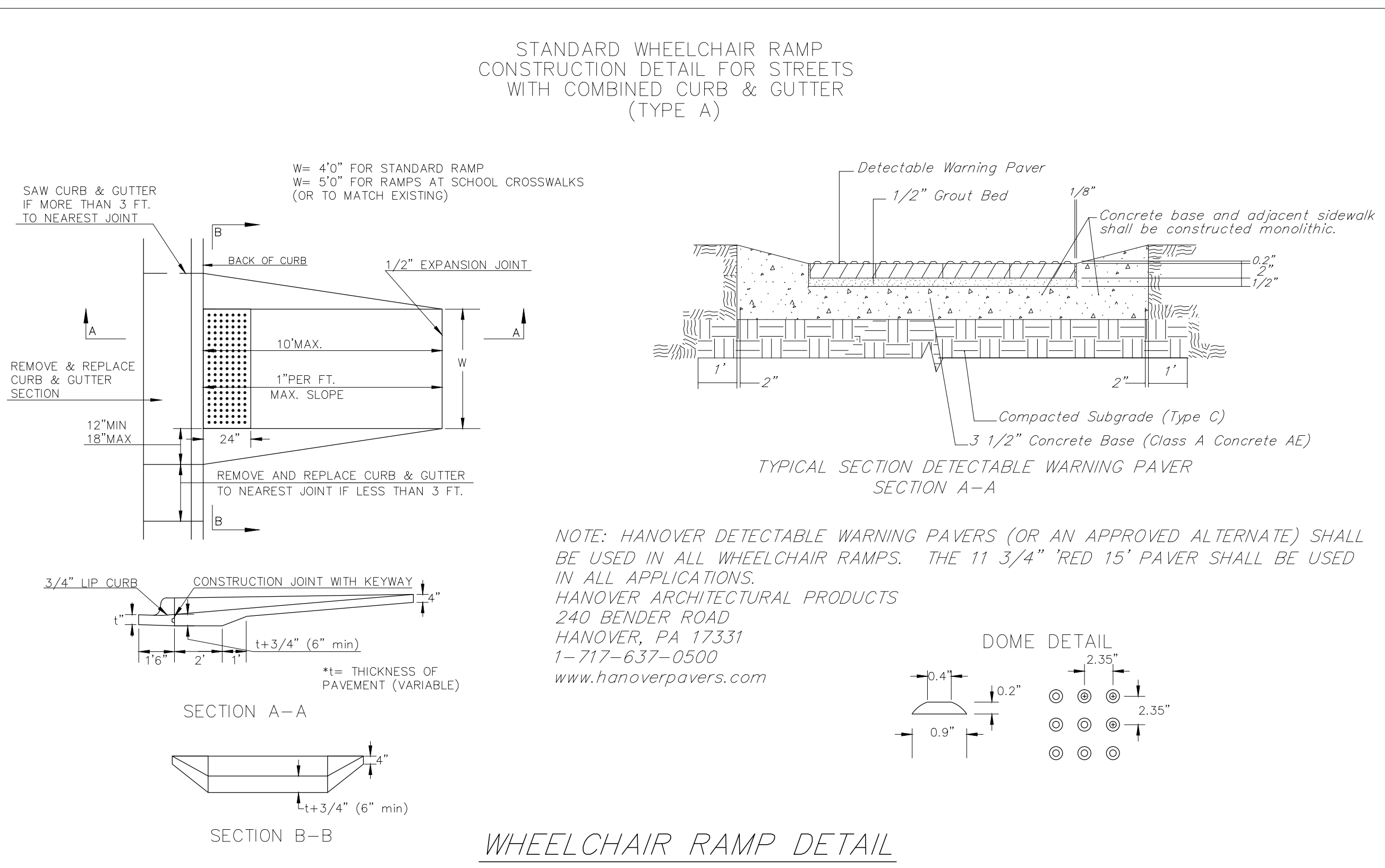

WHEELCHAIR RAMP DETAIL

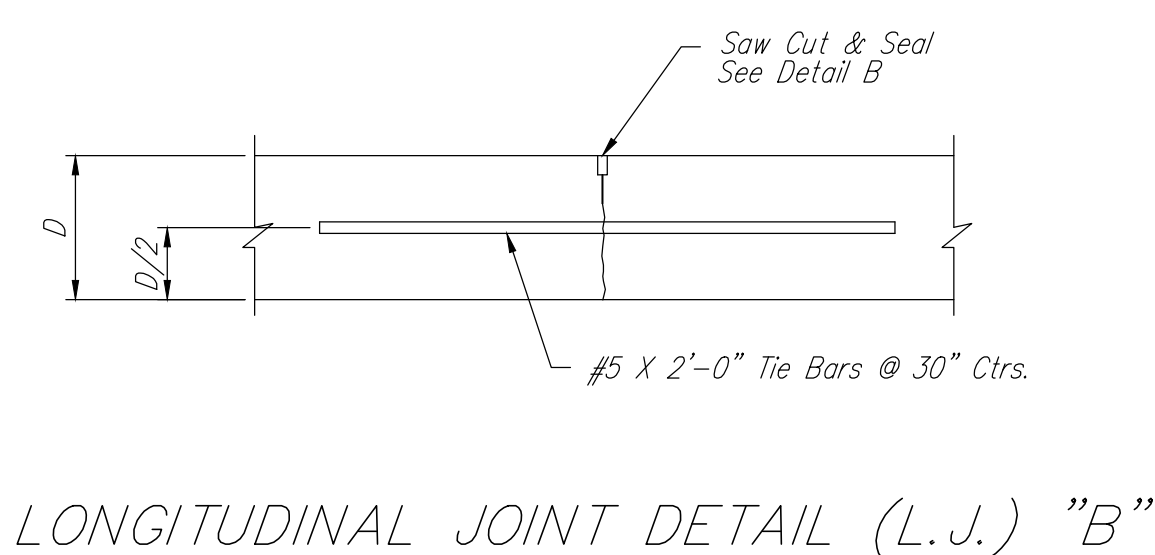

LONGITUDINAL JOINT DETAIL (L.J.) "B"

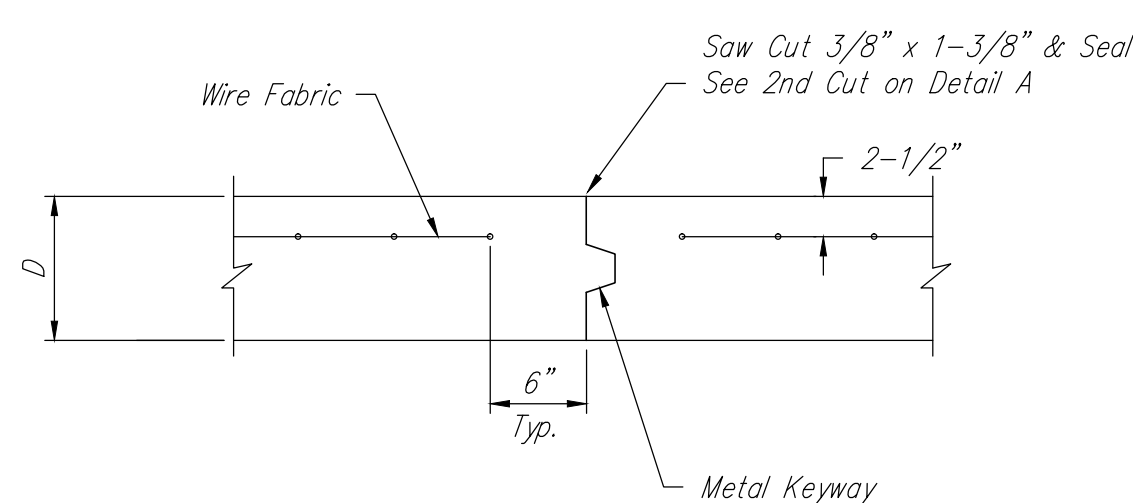

OPTIONAL CONTRACTION JOINT (CONSTRUCTION JOINT)

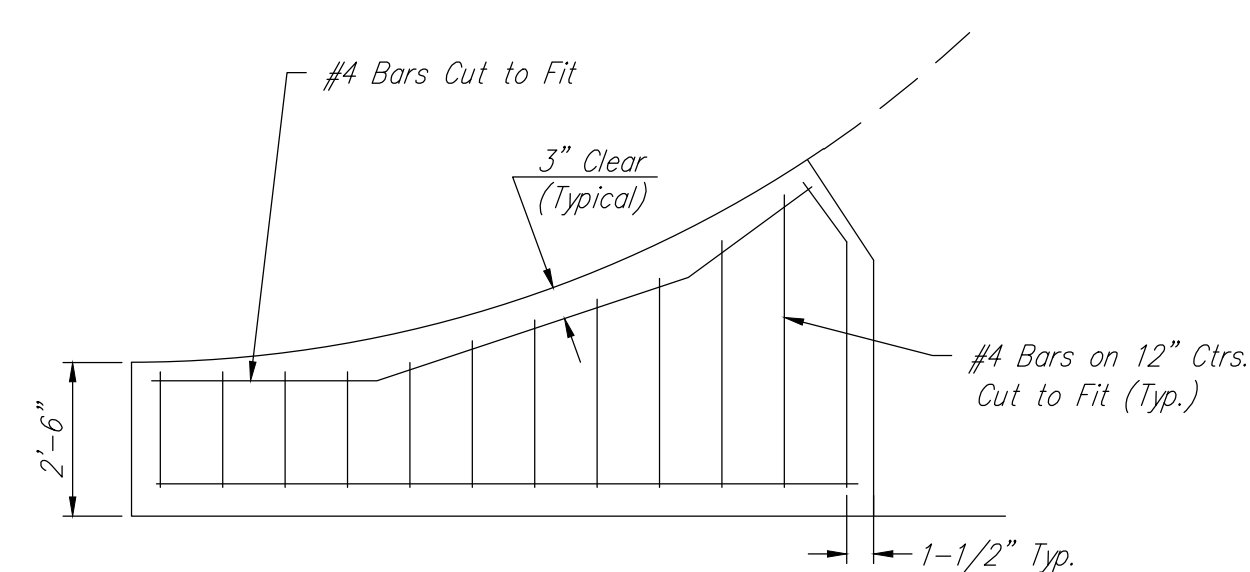

WING REINFORCING DETAIL

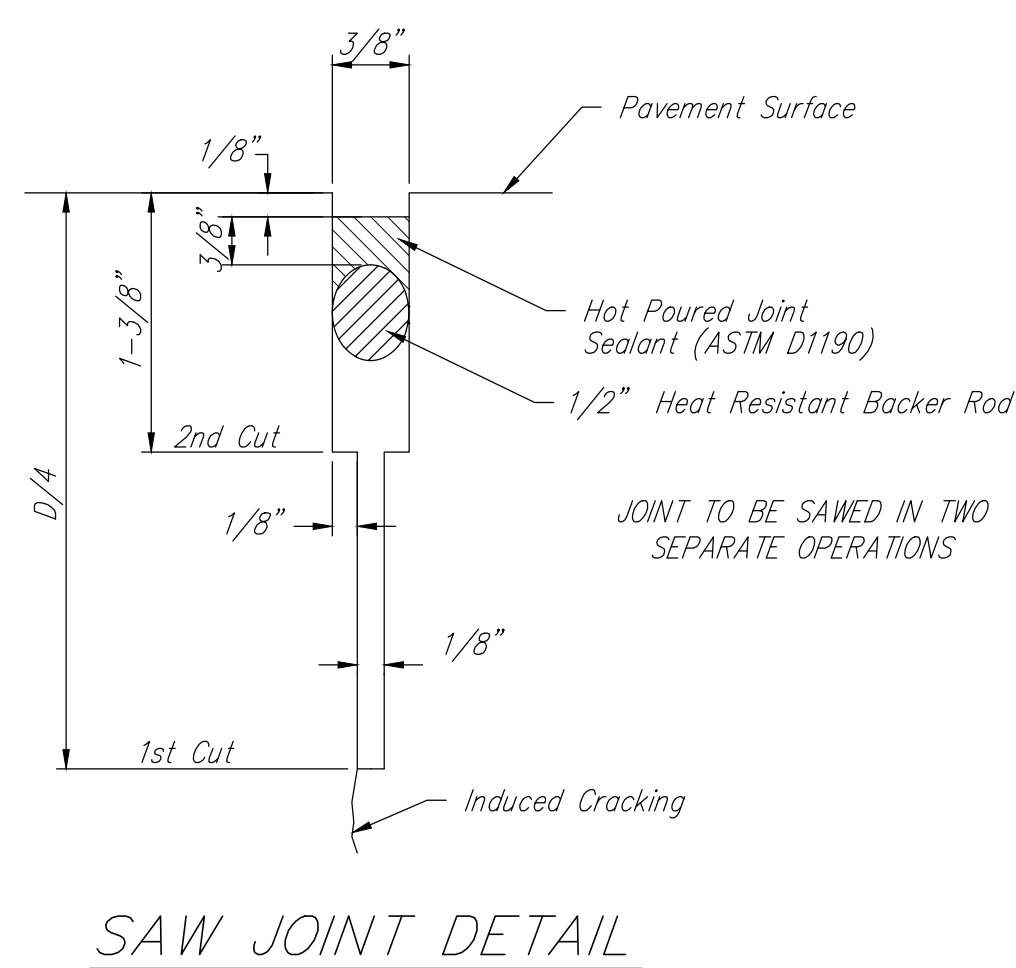

SAW JOINT DETAIL

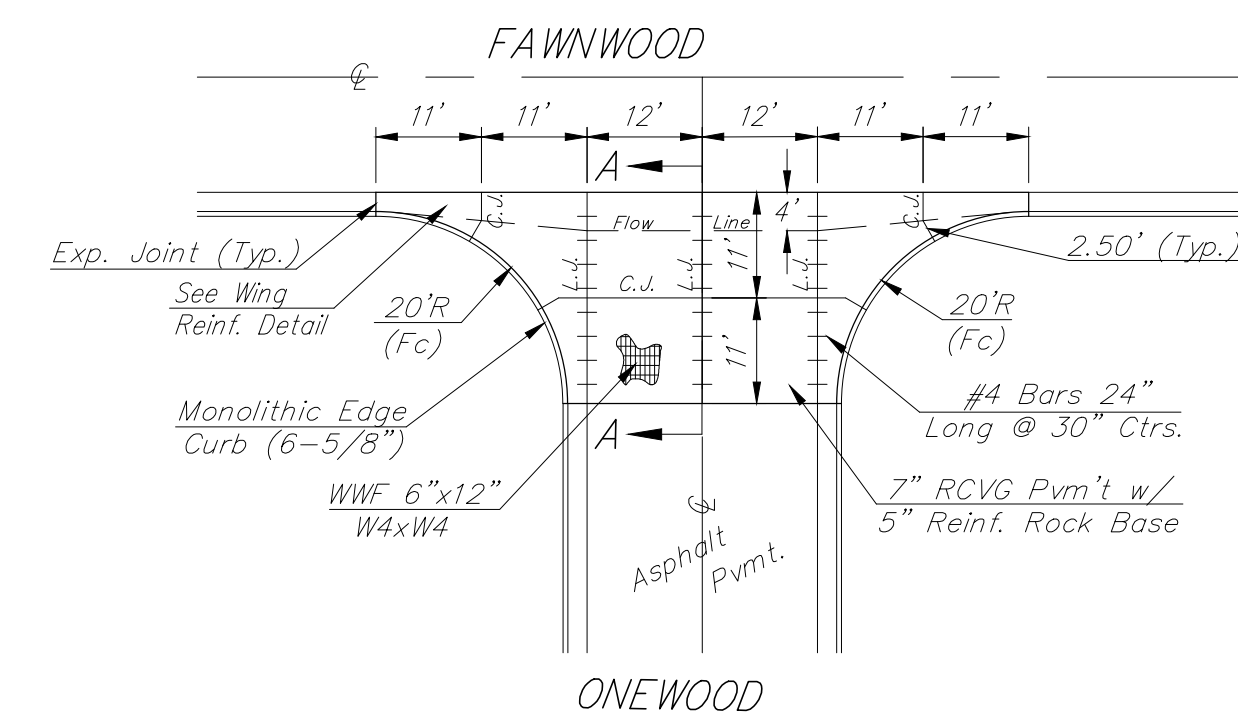

REINFORCED VALLEY GUTTER DETAIL

Scale: 1" = 20'

6" x 12" W4XW4 WIRE FABRIC REINFORCING SHALL BE PLACED SUCH THAT THE WIRES WITH THE 6" SPACING WILL RUN PARALLEL WITH THE LONGITUDINAL JOINT.

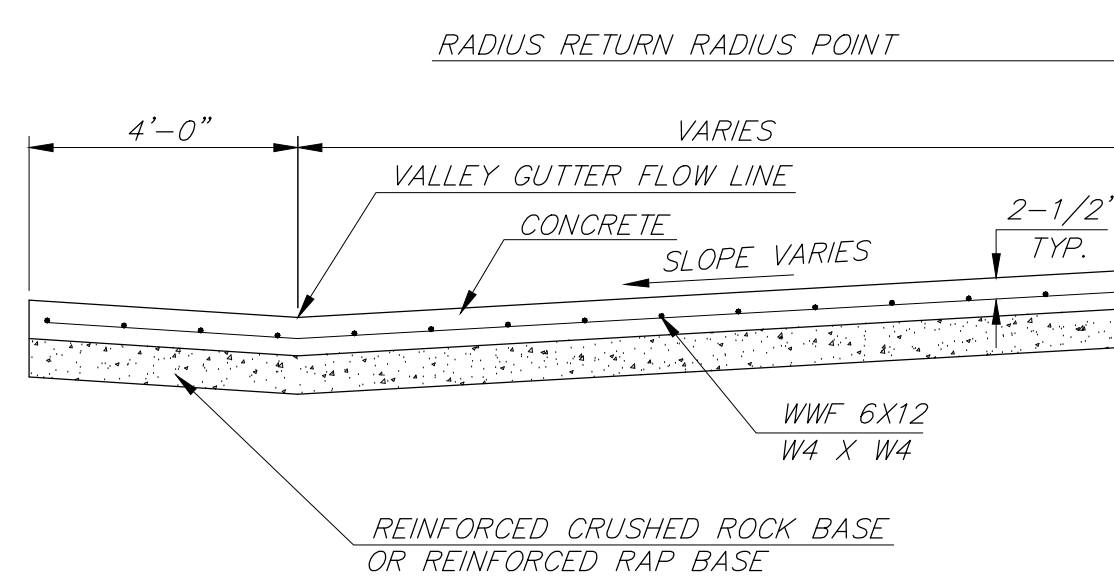

SECTION A-A

	AUBURN HILLS 16th PHASE 1A VALLEY GUTTER DETAILS WHEELCHAIR RAMP DETAILS	
	Baughman Company, P.A. 315 Ellis St. Wichita, KS 67211 P 316-262-7271 F 316-262-0149 ENGINEERING SURVEYING PLANNING LANDSCAPE ARCHITECTURE	
PROJECT NUMBER 472-84290	DESIGN AEG	DRAWN JAK
REVISIONS:	APPROVED	DATE 08/08/16
	SCALE 1" = 20'	SHEET 5 OF 21