

Combined Curb & Gutter (6")

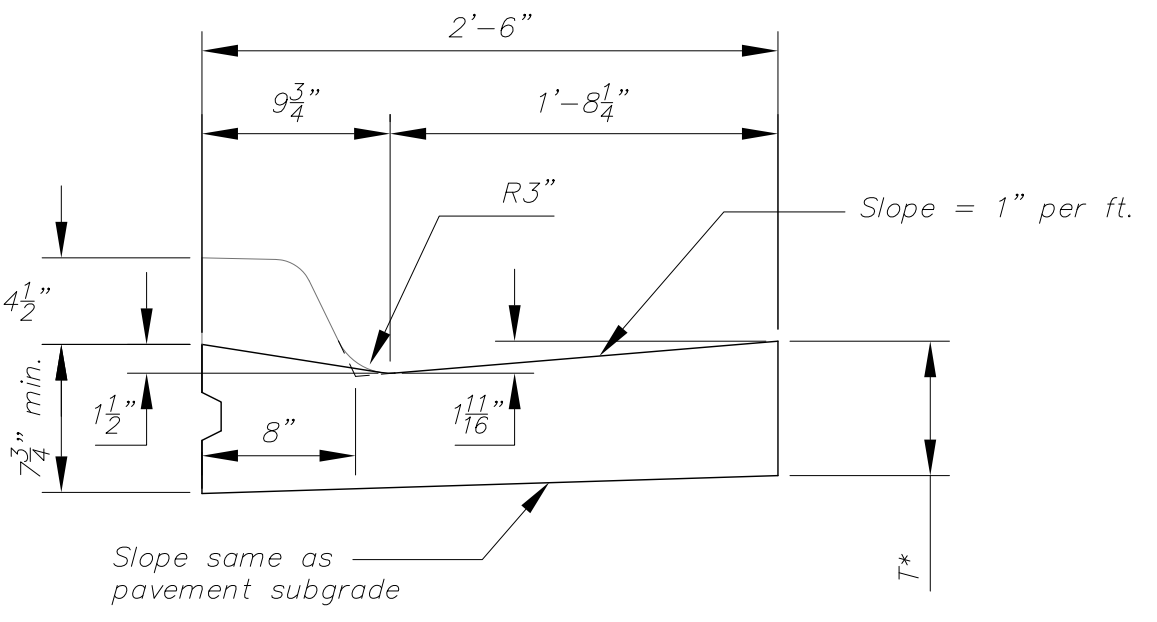

Combined Curb & Gutter (1 1/2")

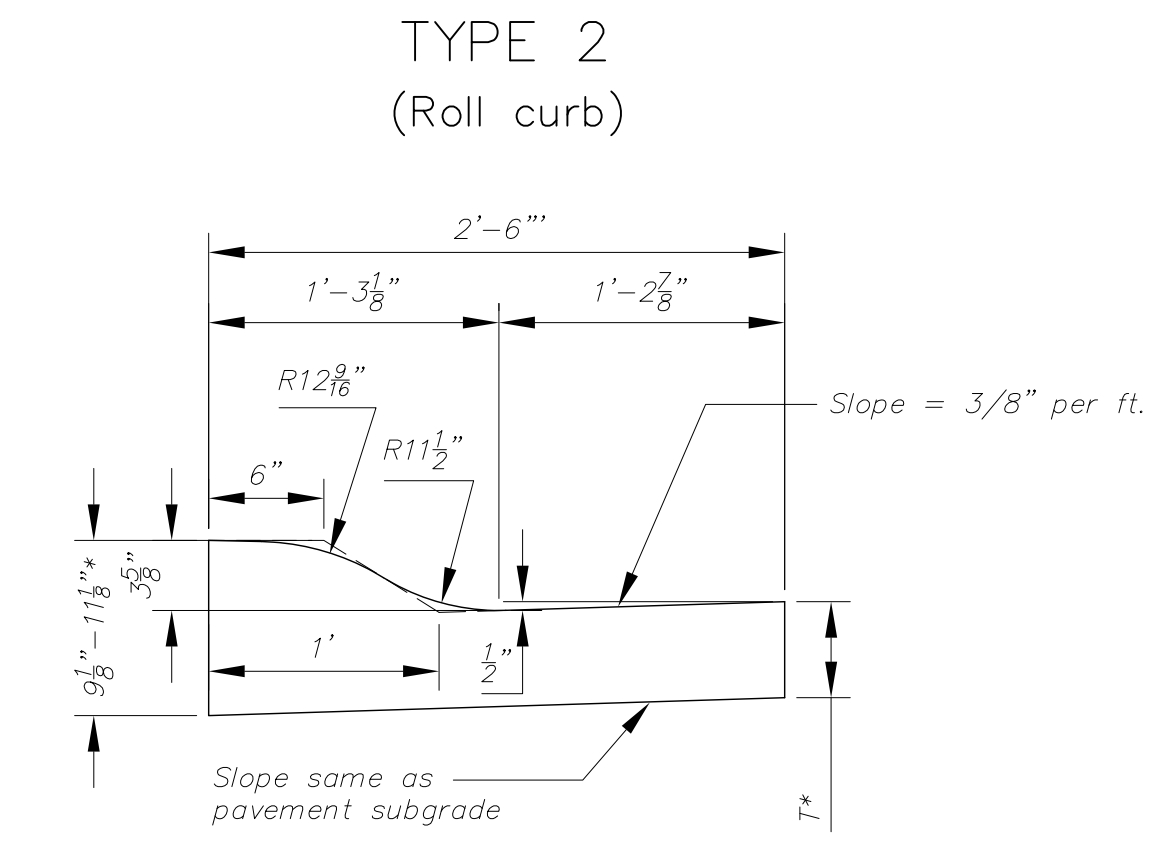

Combined Curb & Gutter (3 5/8")

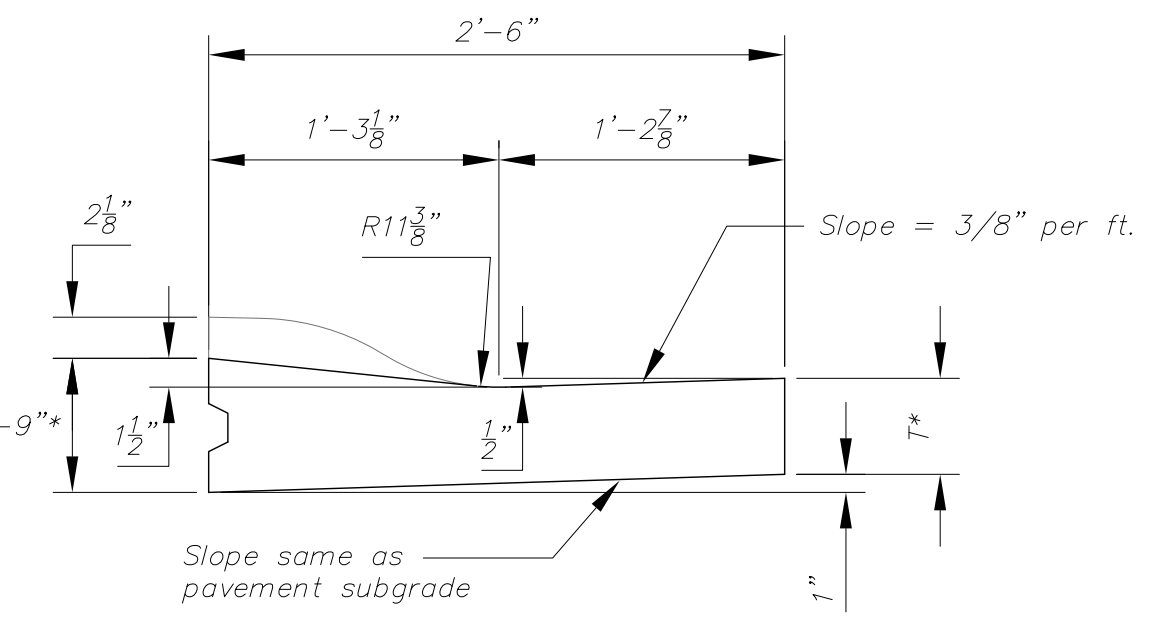

Combined Curb & Gutter (1 1/2")

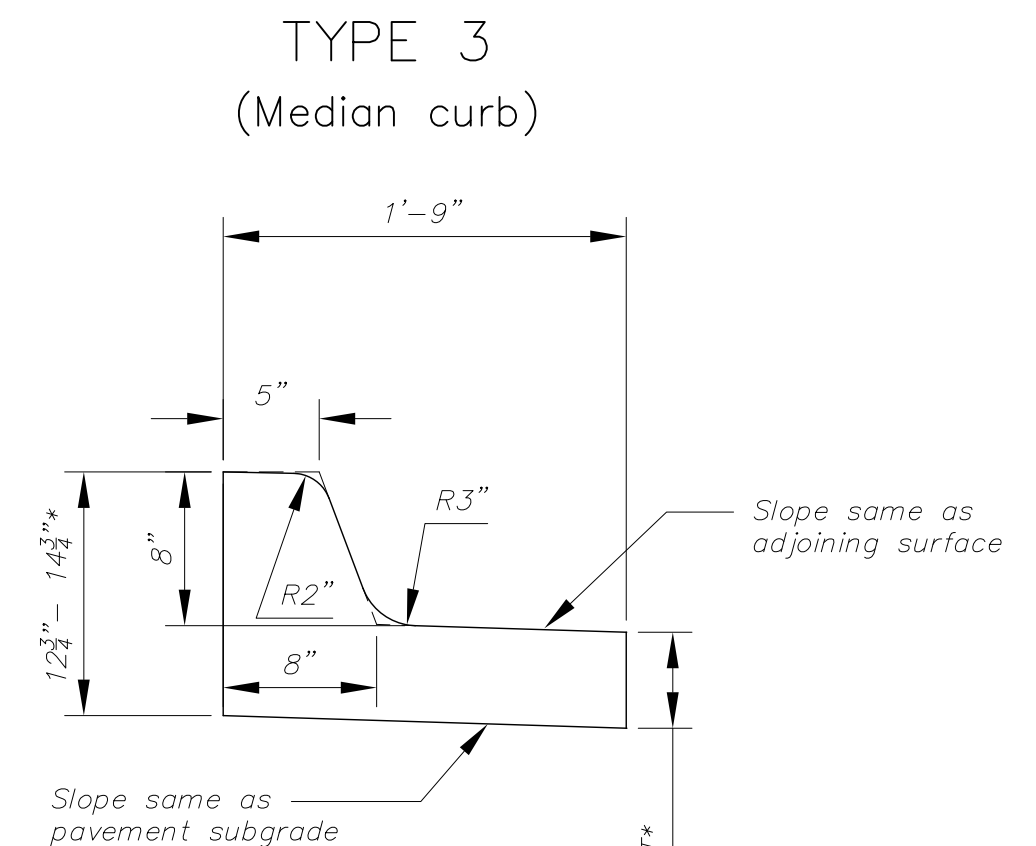

Combined Curb & Gutter (8")

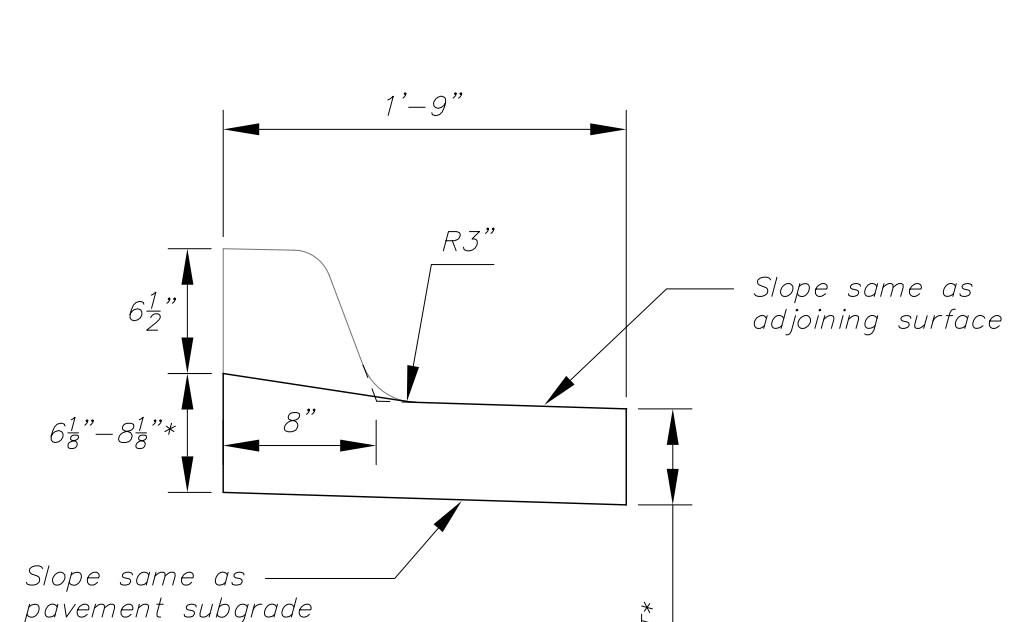

Combined Curb & Gutter (1 1/2")

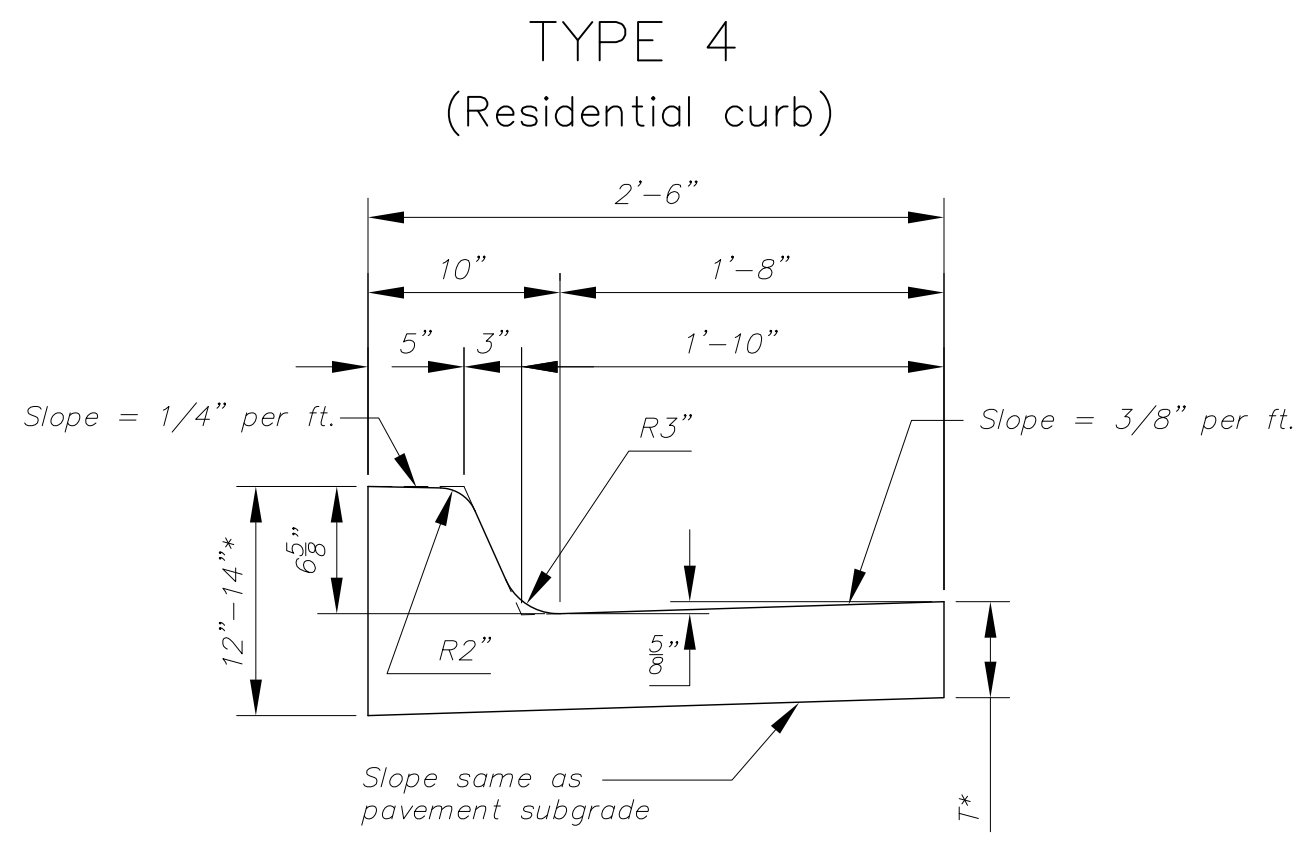

Combined Curb & Gutter (6 5/8")

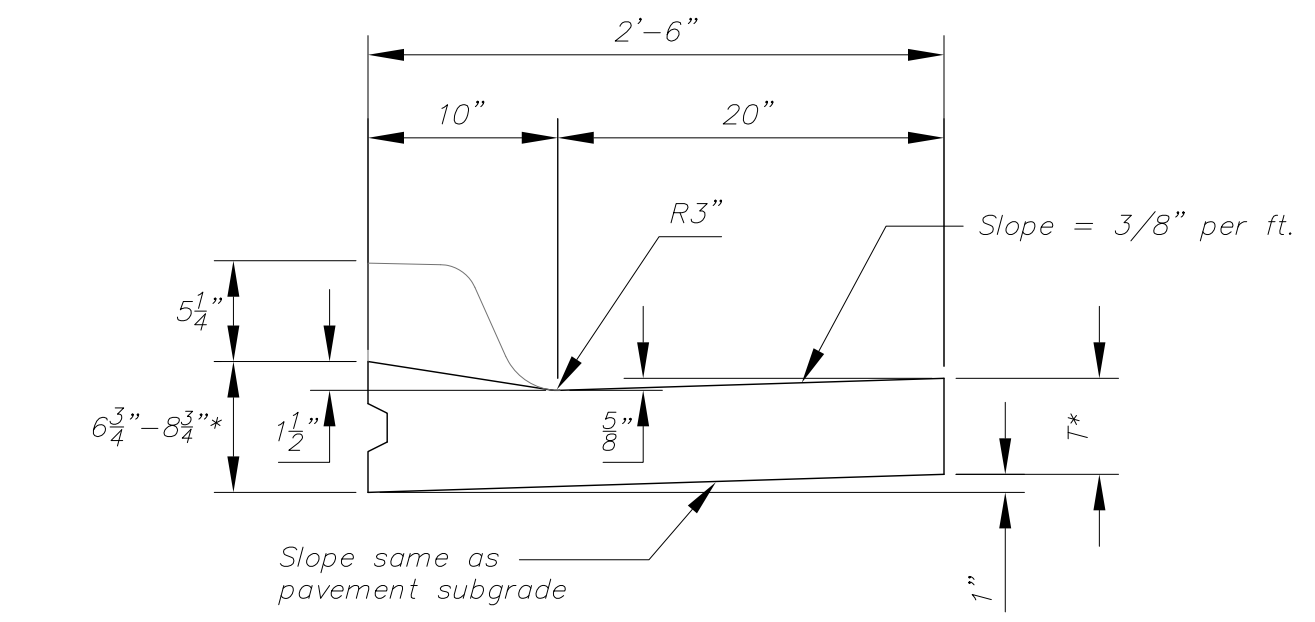

Combined Curb & Gutter (1 1/2")

T* = Thickness of curb to adjust with pavement thickness

GENERAL NOTES

- Expansion (isolation) joints shall be constructed a maximum of 300' apart and at all Pls, PCs, cul-de-sac quadrants, and ends of returns.
- Contraction joints shall be constructed a minimum of 12' apart.
- Joint sealer shall be required at all joints on arterial and industrial streets and at intersections on residential streets.

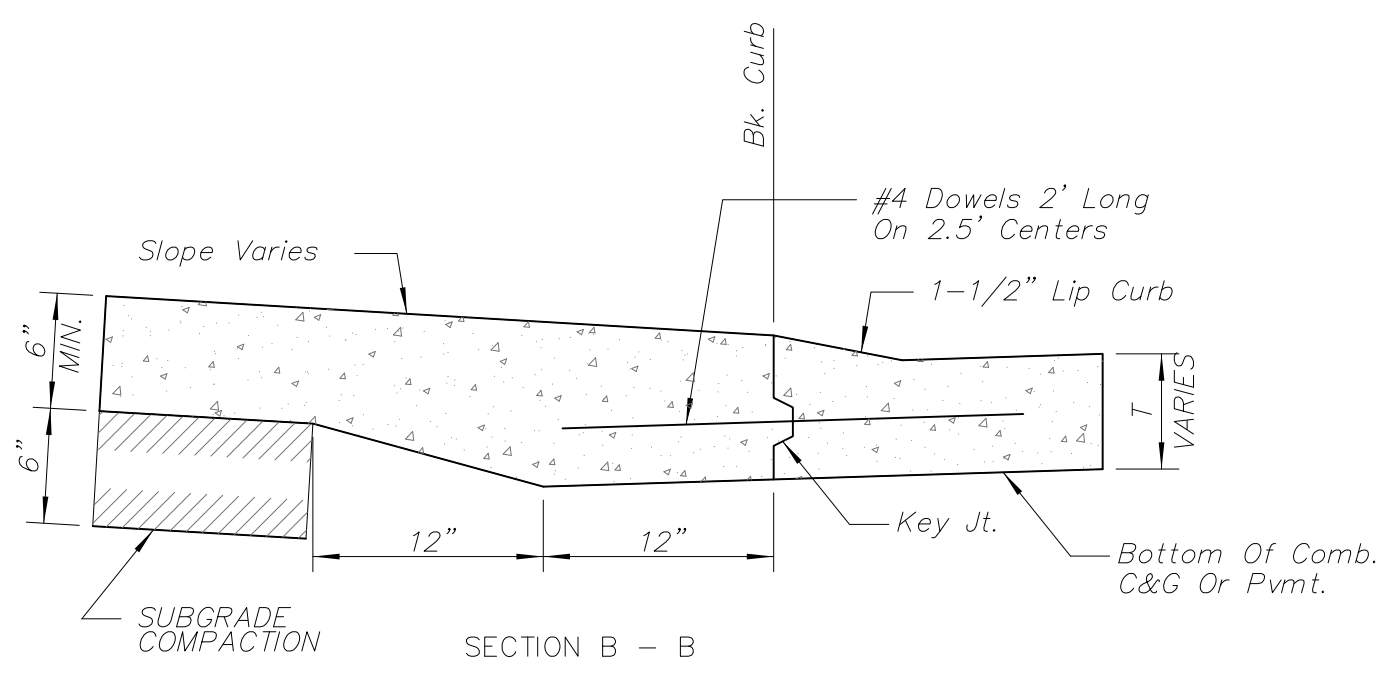

BACK OF CURB DETAIL

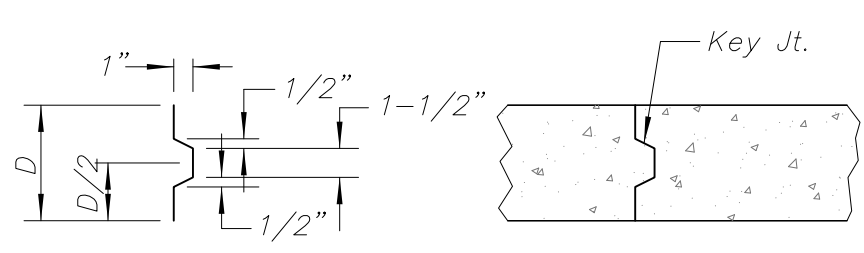

ALT. LONGITUDINAL CONSTRUCTION JOINT

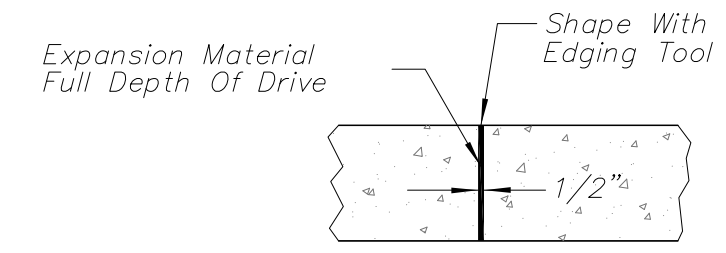

EXPANSION JOINT (E.J.)

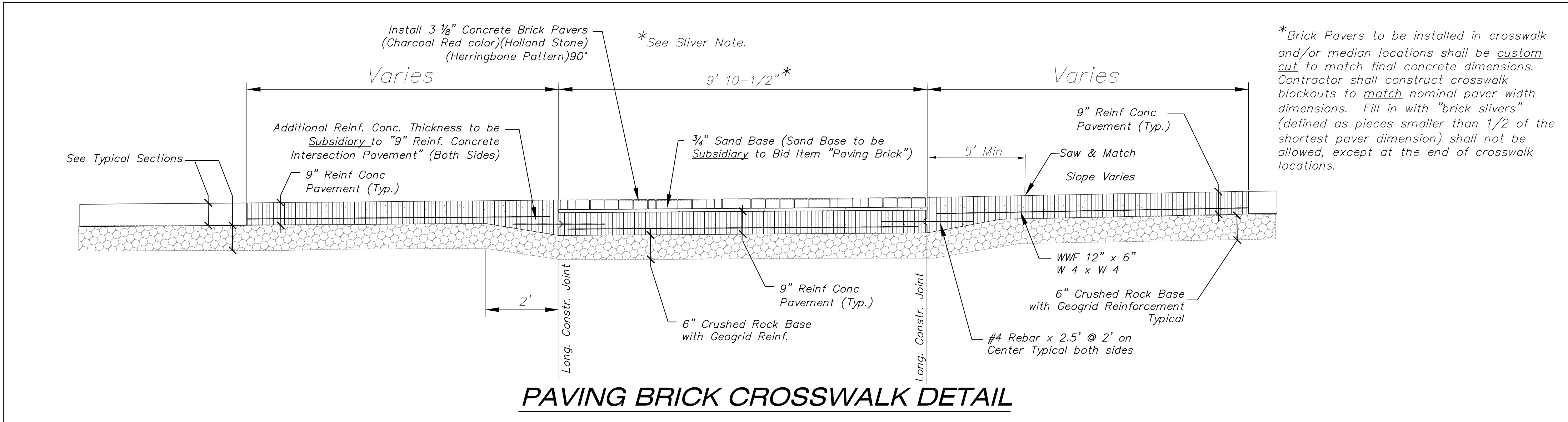

PAVING BRICK CROSSWALK DETAIL

*Brick Pavers to be installed in crosswalk and/or median locations shall be custom cut to match final concrete dimensions. Contractor shall construct crosswalk blockouts to match nominal paver width dimensions. Fill in with "brick slivers" (defined as pieces smaller than 1/2 of the shortest paver dimension) shall not be allowed, except at the end of crosswalk locations.

			REVISED: OCTOBER 2015 CURB & GUTTER & PAVING BRICK CROSSWALK DETAILS CITY ENGINEER GARY JANZEN, P.E.		
PROJECT NUMBER	OCA NUMBER	DATE			
CITY ENGINEER'S OFFICE		SHEET			
CITY HALL - SEVENTH FLOOR		455 NORTH MAIN STREET		3	
WICHITA, KANSAS 67202-1620		(316) 268-4501			