

PLOTTED: Thursday, September 22, 2016 @ 02:34PM

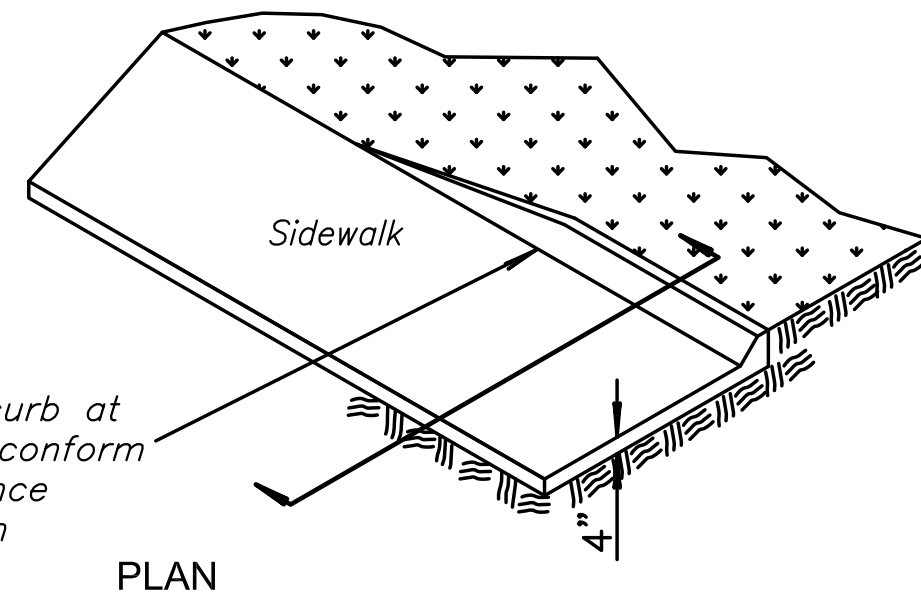

Transition Protection curb at ends as necessary to conform to ground slope. Distance may vary depending on adjacent conditions.

Note:

1. Protection Curb shall be constructed at locations as directed by Engineer.
2. Protection Curb shall be constructed monolithically with sidewalk.
3. Protection Curb height will vary as shown on grading sheets. No distinction will be made between heights regarding payment.

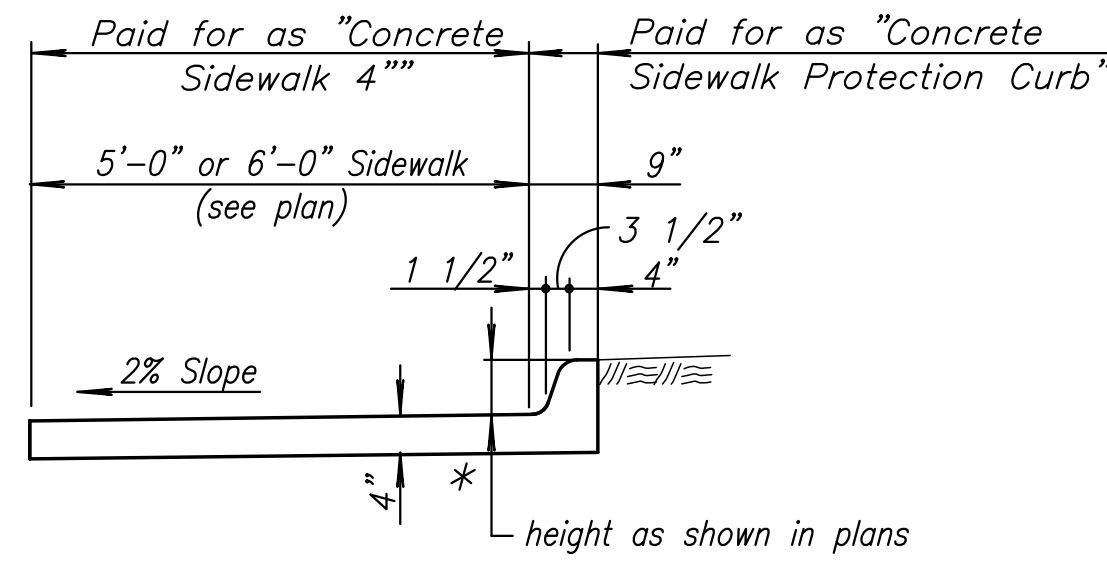

SECTION

* Transition at ends as shown on the plans.

CONCRETE SIDEWALK PROTECTION CURB

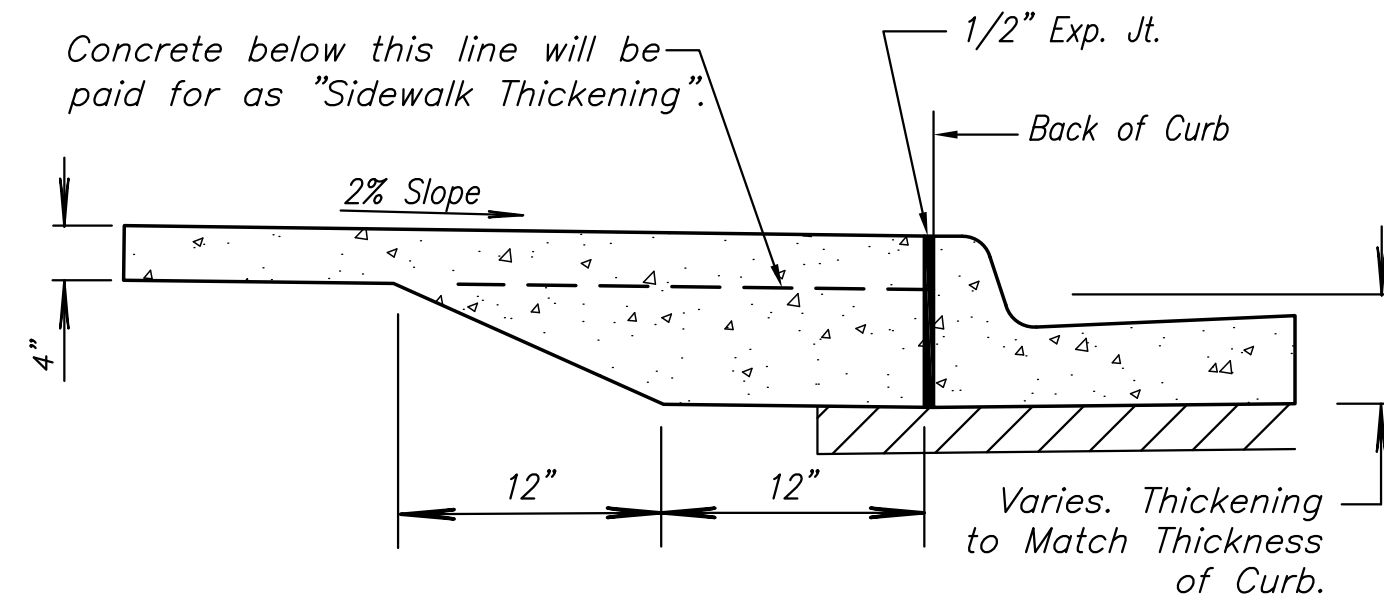

SIDEWALK THICKENING

Note: All Sidewalk at Back of Curb Shall Conform to this Detail

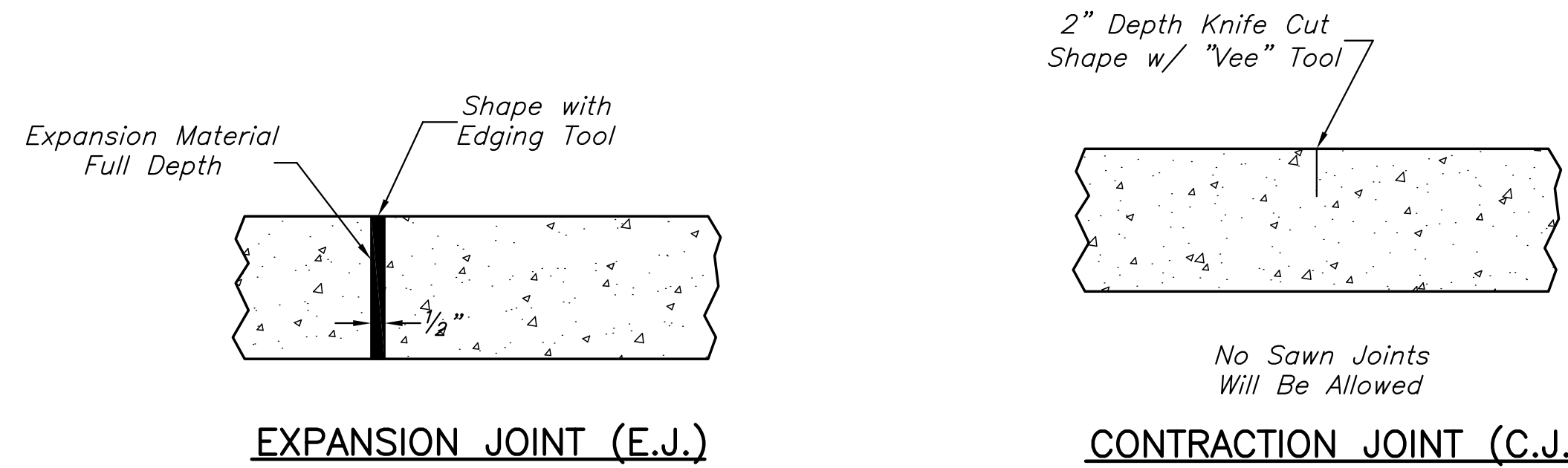

EXPANSION JOINT (E.J.)

CONTRACTION JOINT (C.J.)

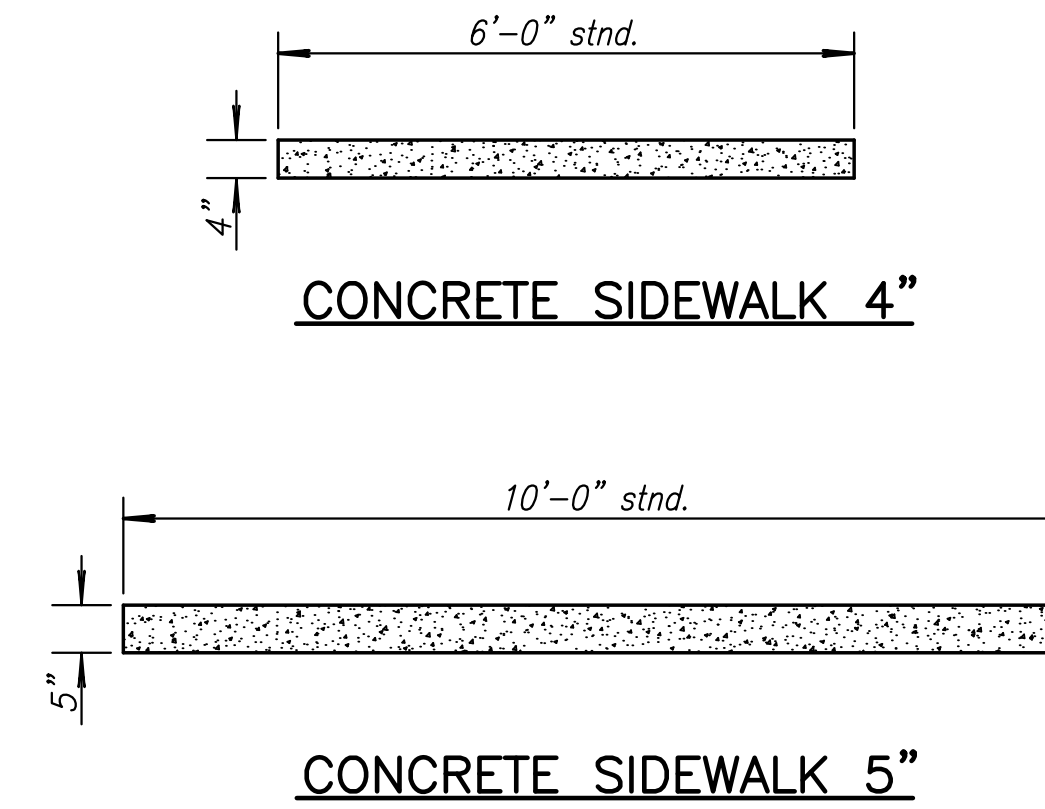

CONCRETE SIDEWALK 4"

CONCRETE SIDEWALK 5"

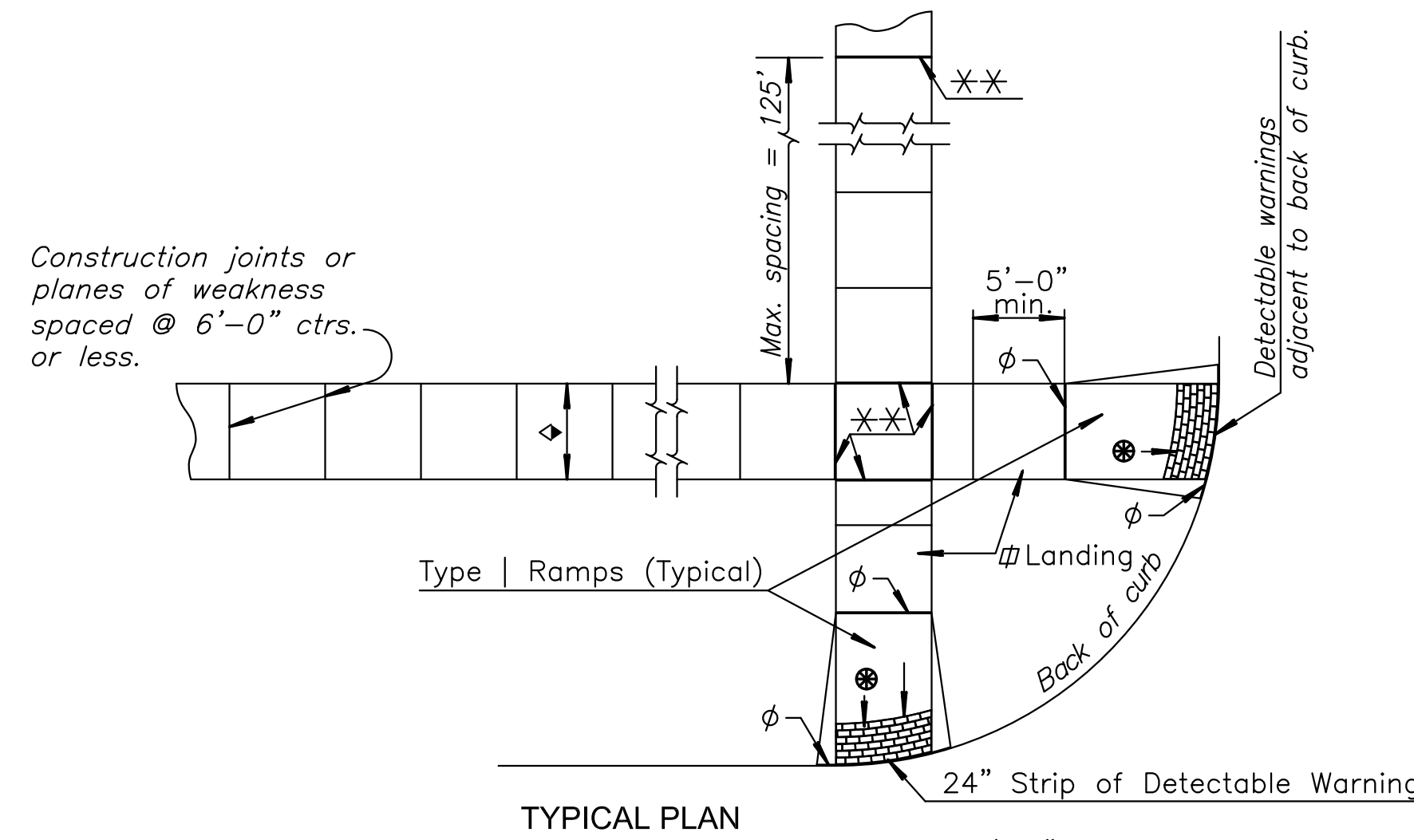

TYPICAL PLAN

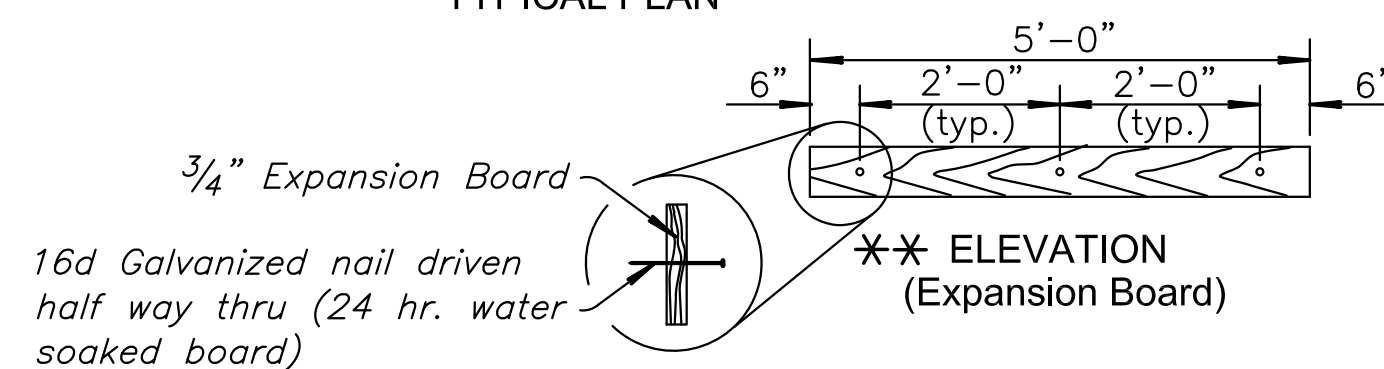

3/4" Expansion Board
16d Galvanized nail driven half way thru (24 hr. water soaked board)

** ELEVATION (Expansion Board)

For other than 5'-0" (width) use 6" from the end and balanced (3'-0" max.) nail spacing.

- φ Expansion Joint (3/4" board) placed at either back of curb line or at sidewalk back of curb line or at sidewalk line.
- ** Expansion joint (3/4" board) located as shown.
- ◇ Variable width (5'-0" min.). Entrance walk to be same width as approach walk. Use sidewalk width of 4'-0" where existing conditions prohibit use of 5'-0".
- ☆ New construction ramp slopes are 12:1 or flatter. Desirable ramp slopes for existing sites are 12:1 or flatter. Where space limitations prohibit construction of a 12:1 slope on existing sites, use the following slopes: 8:1 or flatter for a maximum rise of 3 inches; 10:1 or flatter for a maximum rise of 6 inches
- ⊕ Use a landing slope of 48:1 or flatter. Landings are the same width as ramp and a minimum 5'-0" in length.
- ⊖ Use a counter slope of 20:1 or flatter at the base of sidewalk ramps. See curb and gutter detail sheet.

TYPICAL SIDEWALK PLAN AND DETAILS

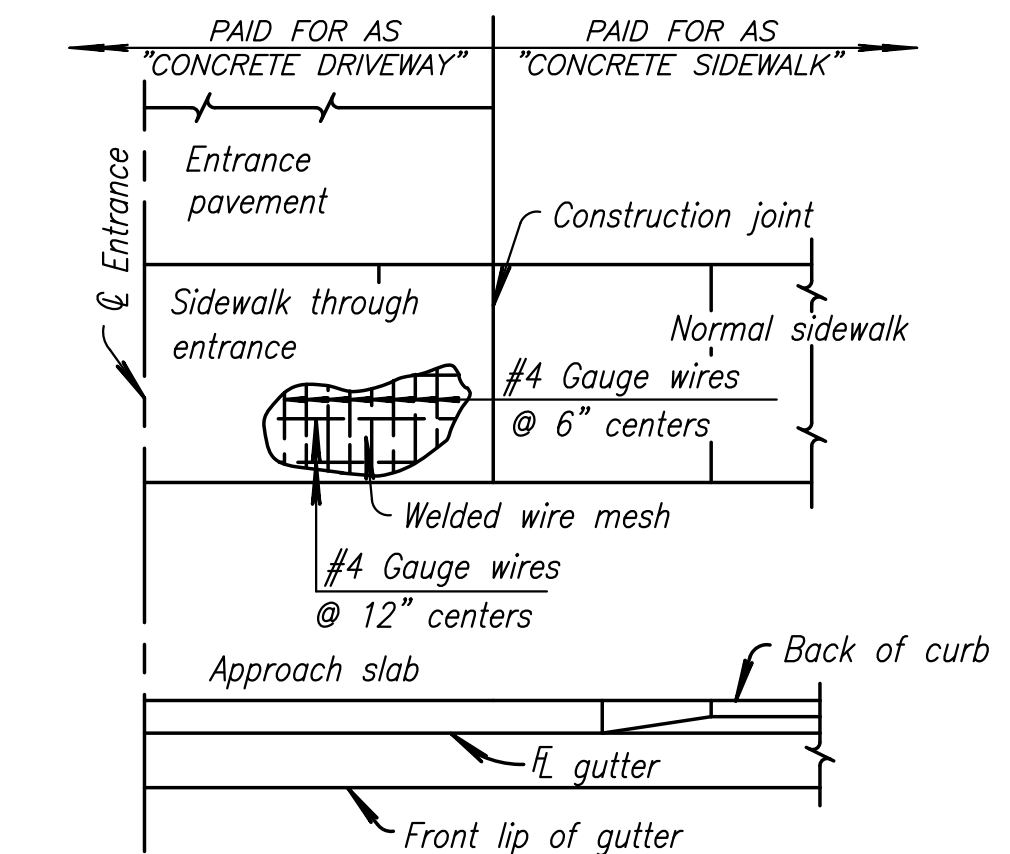

REINFORCEMENT DIAGRAM SIDEWALK THROUGH DRIVE APPROACH

©2016 MKEC Engineering All Rights Reserved www.mkec.com
These drawings and their contents, including, but not limited to, all concepts, designs, & ideas are the exclusive property of MKEC Engineering (MKEC), and may not be used or reproduced in any way without the express consent of MKEC.

SIDEWALK DETAILS

PROJECT NO.	472-85213
DATE	SEPT. 2016
SCALE	NO SCALE
DESIGNED	JRA
DRAWN	DSN
CHECKED	JRA
#	----
NO.	REVISION
	DATE

J:\PROJECTS\2016\150104078_COW_21ST & OLIVER_XXXXXX CAD\SHS\05 CIVIL\PAV1517\FRD06.DWG