

STREET IMPROVEMENTS FOR
21ST & OLIVER INTERSECTION
WICHITA, KANSAS

©2016 MKEC Engineering
All Rights Reserved
www.mkec.com
These drawings and their contents, including, but not limited to, all concepts, designs, & ideas are the exclusive property of MKEC Engineering (MKEC), and may not be used or reproduced in any way without the express consent of MKEC.

PAVEMENT MARKING PLAN AND DETAILS

PROJECT NO. 472-85213

DATE SEPT. 2016

SCALE AS SHOWN

DESIGNED DRAWN CHECKED
JRA DMU JRA

NO.	REVISION	DATE

SHEET NO.

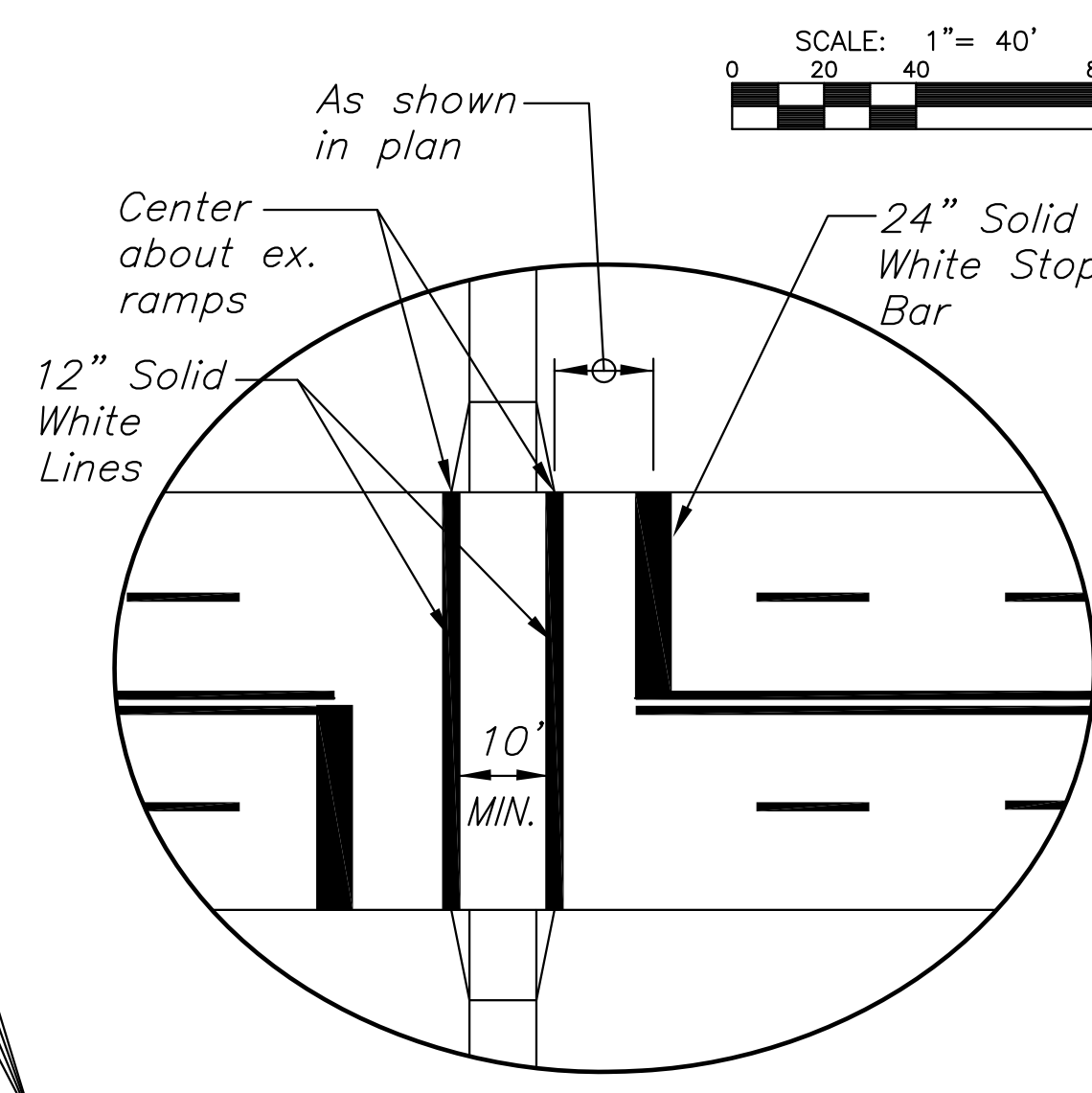
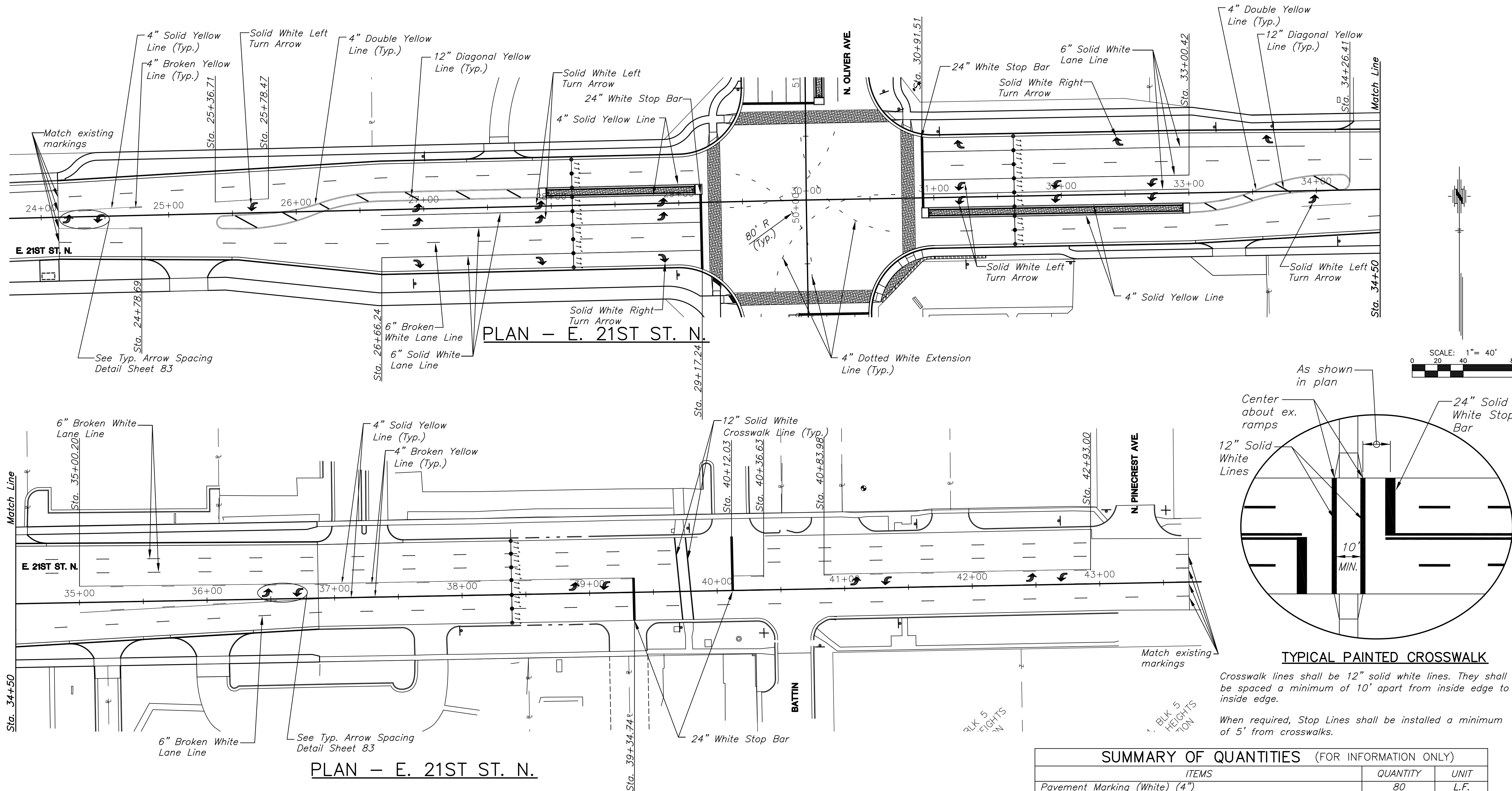

TYPICAL PAINTED CROSSWALK
Crosswalk lines shall be 12" solid white lines. They shall be spaced a minimum of 10' apart from inside edge to inside edge.
When required, Stop Lines shall be installed a minimum of 5' from crosswalks.

SUMMARY OF QUANTITIES (FOR INFORMATION ONLY)

ITEMS	QUANTITY	UNIT
Pavement Marking (White) (4")	80	L.F.
Pavement Marking (Yellow) (4")	14086	L.F.
Pavement Marking (White) (6")	7315	L.F.
Pavement Marking (White) (12")	130	L.F.
Pavement Marking (Yellow) (12")	442	L.F.
Pavement Marking (White) (24")	302	L.F.
Pavement Marking Symbol (Left Turn)	43	Each
Pavement Marking Symbol (Right Turn)	15	Each

ESTIMATED ITEMS DUE TO TEMPORARY TRAFFIC CONTROL (FOR INFORMATION ONLY)

ITEMS	QUANTITY	UNIT
Pavement Marking (Yellow) (4")	3439	L.F.
Pavement Marking (White) (6")	2027	L.F.
Pavement Marking (White) (12")	160	L.F.
Pavement Marking (White) (24")	80	L.F.
Pavement Marking Symbol (Left Turn)	6	Each

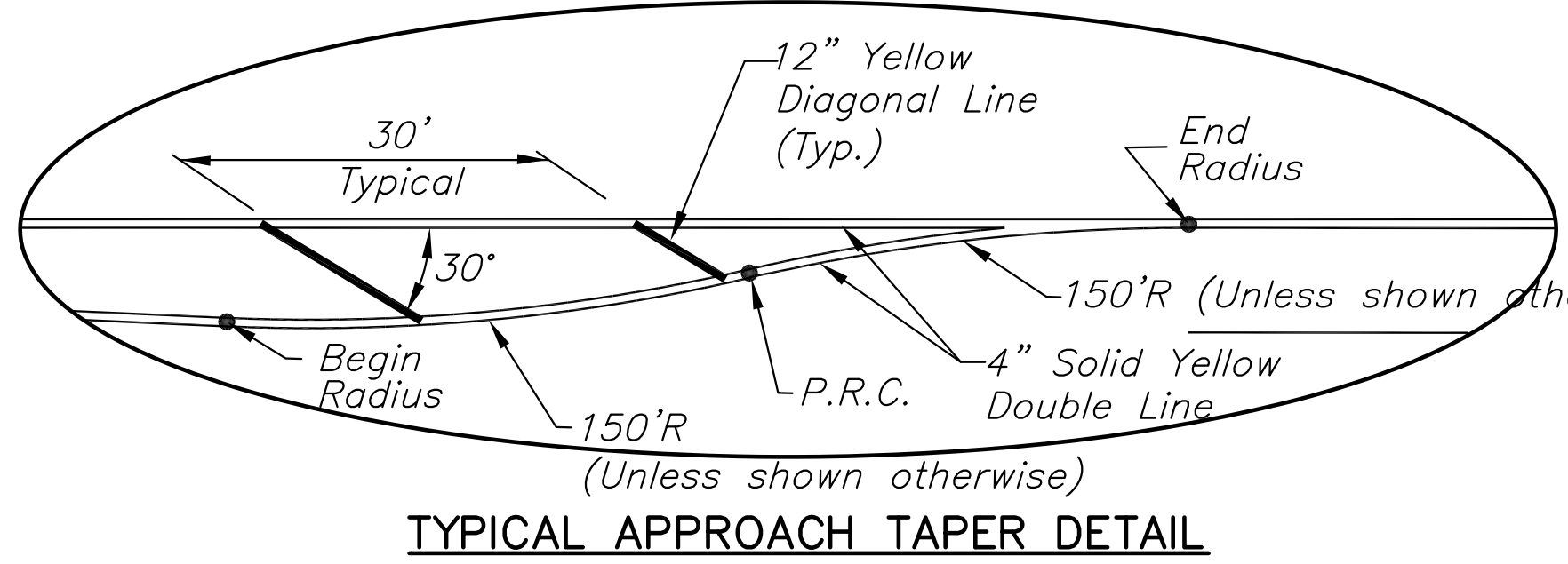

Pavement Markings – All pavement markings shall be epoxy, unless otherwise approved by the Engineer. Pavement markings shall be installed per manufacturer's recommendations and shall meet KDOT's 2007 Edition of the Standard Specification Section 806. Full traffic may not be restored (and substantial project completion achieved) until all pavement markings are in place. Should construction timing be such that restoration of traffic becomes necessary during temperatures prohibiting the installation of permanent markings, the contractor shall install and maintain temporary markings until such time that permanent markings may be properly installed. Except for the material requirement, temporary pavement markings shall be placed equivalent, in every manner (i.e. dimension, frequency, spacing, etc.), to the permanent marking layout. The cost for temporary pavement markings will not be paid for directly, but shall be considered *subsidiary* to the bid item "Traffic Control".

NOTE: Existing Pavement Marking removed for temporary traffic control purposes shall be replaced, in-kind on 21st and Oliver. Quantities for this are reflected in the Summary of Quantities.

RECAPITULATION OF QUANTITIES

BID ITEM	QUANTITY	UNIT
Pavement Marking	Lump Sum	L.S.

J:\PROJECTS\2016\19104078_COW_21ST & OLIVER_XXXXXX CAD\SHS\505 QWALP\PAV15178E.MXD
 PLOTTED: Thursday, September 22, 2016 @ 04:00PM