

CONTROL PANEL SCHEDULE

Panel No.	Service (Location)	Mounting	NEMA 250 Rating	Dimensions (Nominal)			FDT	Fan	Space Heater	Serv. Lights, Outlets	Environment	SS	NOTES
				H	W	D							
IMUX-41902-RIO	Remote IO for IMUX-41902	Wall mount	Nema 12	30"	30"	16"	Yes	No	No	No	Inside Heated	Yes	CONTRACTOR TO DESIGN, BUILD AND INSTALL
IMUX-43901-RIO	Remote IO for IMUX-43901	Floor Mount	Nema 12	30"	30"	16"	Yes	No	No	No	Inside Heated	Yes	
IMUX-41902	EXISTING-HEADWORKS	existing									existing		CONTRACTOR TO RETROFIT AS INDICATED ON ASSOCIATED WORKSHEET
IMUX-43901	EXISTING-SLUDGE 300	existing									existing		CONTRACTOR TO RETROFIT AS INDICATED ON ASSOCIATED WORKSHEET
IMUX-41901	EXISTING OLD IPS	existing									existing		CONTRACTOR TO RETROFIT AS INDICATED ON ASSOCIATED WORKSHEET
LCP-41101	Gas Detector Panel Screenings Room	Wall mount	NEMA-4X	24	24	8	No				Class1 Div2	Yes	VENDOR
LCP-42702	Gas Detector Panel Odor Control Facility	Wall mount	NEMA-4X	24	24	8	No				Class1 Div2	Yes	VENDOR
LCP-42701	Odor Control Exhaust Fan Panel	See HVAC Spec	See HVAC Spec										BY HVAC
LCP-41100A1	Screenings PLC Control Panel	See spec 44_42_35	See spec 44_42_35										VENDOR
LCP-41100B1	Washer/Compactor PLC Control Panel	See spec 44_42_35	See spec 44_42_35										VENDOR
LCP-43200	RDT PLC Control Panel	See spec 44_46_26.03B	See spec 44_46_26.03B										VENDOR
LCP-43500	Centrifuge PLC Control Panel	See spec 43_22_25i	See spec 43_22_25i										VENDOR
LCP-42101A	UV Reactor 1 PLC Control Cabinet	See spec 44_44_73i	See spec 44_44_73i										VENDOR
LCP-42102A	UV Reactor 2 PLC Control Cabinet	See spec 44_44_73i	See spec 44_44_73i										VENDOR
LCP-42101A	UV Reactor 1 Local Control Station	See spec 44_44_73i	See spec 44_44_73i										VENDOR
LCP-42102A	UV Reactor 2 Local Control Station	See spec 44_44_73i	See spec 44_44_73i										VENDOR
LCP-41700	Ferric Chloride Truck Unloading Panel	Wall mount	NEMA4X										CONTRACTOR TO DESIGN, BUILD AND INSTALL
NIP-110	Network Interface Panel	Wall mount	NEMA 12										CONTRACTOR TO DESIGN, BUILD AND INSTALL

Column Descriptions:
 FDT: Factory Demonstration Test Required
 All Dimensions: approximate,contractor to layout according to space required to house required equipment.
 SS: Stainless Steel Required

NIP-110

<u>ITEM</u>	<u>QTY</u>	<u>Manuf</u>	<u>P/N</u>	<u>DESCRIPTION</u>
1	1			Cabinet UPS
2	1	Hirschman	RS2-8TX EEC	8-port switch
3	1			24 VDC POWER SUPPLY

CONTRACTOR TO DESIGN, BUILD AND INSTALL LCP-41700

LCP-41700

Ferric Chloride Truck Unloading Panel

Red Lion Display MODEL PAXLCL

Edwards Model 51SIN Series Combination Beacon and Horn

Alarm/Acknowledge button

Wire analog signal from LIT-41700 into this box for local display. Re-broadcast AI to PLC. Program local Hi and Hi-Hi Level alarms to actuate local Horn/Beacon.

Provide local alarm silence button

CONTRACTOR TO DESIGN, BUILD AND INSTALL LCP-41700

IMUX-41902(refurbish existing)

IMUX CABINET	SLOT	Manuf	RX3i Card	DESCRIPTION	NOTES	NOTES
41902		GE	IC695ECM850	PACSystems RX3i IEC61850-Ethernet module	add new card	
41902	02	GE	IC693DNM200	Devicenet Scanner	REPLACE EXISTING CARD WITH Rx3I Card	
41902	03	GE	IC693MDL645	24 Volt 16 ch Discrete Input Card	REPLACE EXISTING CARD WITH Rx3I Card	
41902	04	GE	IC693MDL645	24 Volt 16 ch Discrete Input Card	REPLACE EXISTING CARD WITH Rx3I Card	
41902	06	GE	IC693MDL930	24 Volt 16 ch Discrete Output Card	REPLACE EXISTING CARD WITH Rx3I Card	
41902	08	GE	ICC693ALG222	16 Ch analog Input Card	REPLACE EXISTING CARD WITH Rx3I Card	
41902	10	GE	IC695PNC001	Profinet Controller	Add Profinet Controller	USED TO CONNECT TO NEW 41902-RIO
41902		GE	IC695CHS010	10-slot IO rack	REPLACE EXISTING 10-SLOT RACK	
41902		GE	IC695PSD140	24VDC Rack Power Supply 30 WATTS	REPLACE EXISTING RACK POWER SUPPLY	

IMUX-41902-RIO (new)

<u>ITEM</u>	<u>QTY</u>	<u>Manuf</u>	<u>I/O</u> <u>P/N</u>	See 40 90 00B Supp04 IO List for more detail	<u>SLOT</u>	<u>NOTES</u>
1	1	GE	IC695ECM850	PACSystems RX3i IEC61850-Ethernet module	2	
2	1	GE	IC695ECM850	PACSystems RX3i IEC61850-Ethernet module	3	
3	1	GE	IC695PNS001	Profinet Scanner	4	USED TO CONNECT TO IMUX-41902
4	1	GE	ICC693ALG222	16 Point Analog Input Card	5	
5	1	GE	IC694ALG392	16 Point Analog Output Card	9	
6	1	GE	IC694MDL645	24 VDC 16 pt input Card	6	
7	1	GE	IC694MDL645	24 VDC 16 pt input Card	7	
8	1	GE	IC694MDL930	16 pt Relay Output Card (2 amps)	8	
9	1	GE	IC695CHS012	12-slot IO rack		
10	1	GE	IC695PSD140	24VDC Rack Power Supply 30 WATTS		
11	1			Cabinet UPS		
12	1	Hirschman	RS2-8TX EEC	8-port ethernet switch		
13	1			General Purpose Duplex Receptacle		
14	1			Duplex Receptacle for UPS		
15	1			Cabinet Light		
16	2	Phoenix		24 vdc Power Supply		
17	1			Cabinet fan		
18	1			Fiber Patch Panel		

Route 120 vac power to the following instruments from IMUX-41902-RIO

Bring 120vac circuit into panel, provide breakers and terminals to supply each instruments individually

P&ID NO	INSTRUMENT TAG
090-N-0002	FIT-41075
090-N-0002	LIT-41051
090-N-0003	SSL-41105
090-N-0003	SV-41105
090-N-0003	SV-41101

IMUX-43901 (refurbish existing)

IMUX CABINET	SLOT	RX3i Card	DESCRIPTION	NOTES
43901		GE	IC695ECM850	PACSystems RX3i IEC61850-Ethernet module add new card
43901	02	IC693DNM200	Devicenet Scanner	REPLACE EXISTING CARD WITH Rx3I Card
43901	07	IC693MDL645	24 Volt 16 ch Discrete Input Card	REPLACE EXISTING CARD WITH Rx3I Card
43901	10	IC693MDL930	24 Volt 16 ch Discrete Output Card	REPLACE EXISTING CARD WITH Rx3I Card
43901	1-4	ICC693ALG222	16 Ch analog Input Card	REPLACE EXISTING CARD WITH Rx3I Card
	IC695CHS010	10-slot IO rack	REPLACE EXISTING 10-SLOT RACK	
Local Rack	IC695PSD140	24VDC Rack Power Supply 30 WATTS	REPLACE EXISTING RACK POWER SUPPLY	
Local Rack	IC695LRE001	PACSystems RX3i Expansion Module		
Expansion Rack	IC695PSD140	24VDC Rack Power Supply 30 WATTS	REPLACE EXISTING RACK POWER SUPPLY	
Expansion Rack	IC695LRE001	PACSystems RX3i Expansion Module		
	IC693CBL300	1 METER I/O BUS EXPANSION CABLE	male/female conn at 1 end, female at the	



IMUX-43901-RIO (new)

I/O See 40 90 00B Supp04 IO List for more detail

NOTES

<u>ITEM</u>	<u>QTY</u>	<u>Manuf</u>	<u>P/N</u>	<u>DESCRIPTION</u>	<u>SLOT</u>	
1	1	GE	IC695ECM850	PACSystems RX3i IEC61850-Ethernet module	2	
2	1	GE	IC695ECM850	PACSystems RX3i IEC61850-Ethernet module	3	
3	1	GE	ICC693ALG222	16 Point Analog Input Card	4	
4	1	GE	ICC693ALG222	16 Point Analog Input Card	5	
5	1	GE	IC694ALG392	8 Pt Analog Current Output Card	6	
6	1	GE	IC694MDL645	24 VDC 16 pt input Card	7	
7	1	GE	IC694MDL645	24 VDC 16 pt input Card	8	
8	1	GE	IC694MDL930	16 pt Relay Output Card (2 amps)	9	
9	1	GE	IC695CHS012	12-slot IO rack		
10	1	GE	IC695PSD140	24VDC Rack Power Supply 30 WATTS		
11	1	APC		Cabinet UPS		
12	1			General Purpose Duplex Receptacle		
13	1			Duplex Receptacle for UPS		
14	1			Cabinet Light		
15	2	Phoenix		24 vdc Power Supply		
16	1			Cabinet fan		
17	1	Hirschman	RS2-8TX EEC	8-port ethernet switch		
18	1	GE	IC693CBL313	8 METER I/O BUS EXPANSION CABLE		male/female conn at 1 end, female at the
19	1	GE	IC693ACC307	Terminator Plug		used on last expansion rack (new RIO rack)
20	1	GE	IC695LRE001	Serial Bus Transmitter Module		

Route 120 vac power to the following instruments from IMUX-43901-RIO

<u>P&ID NO</u>	<u>INSTRUMENT TAG</u>
090-N-0008	AIT-41452
090-N-0008	AIT-41453
090-N-0015	FIT-43006
090-N-0015	FIT-40307
090-N-0016	FIT-43005
090-N-0018	FIT-43208
090-N-0020	AIT-43305
090-N-0020	AIT-43304
090-N-0020	AIT-43301
090-N-0020	AIT-43509
090-N-0020	AIT-43508
090-N-0020	AIT-43302

IMUX-41901 (refurbish existing)

IMUX CABINET	SLOT	Manuf	RX3i Card	DESCRIPTION	NOTES
41901		GE	IC695ECM850	PACSystems RX3i IEC61850-Ethernet module	add new card
41901	02	GE	IC693DNM200	Devicenet Scanner	REPLACE EXISTING CARD WITH Rx3I Card
41901	03	GE	IC693MDL645	24 Volt 16 ch Discrete Input Card	REPLACE EXISTING CARD WITH Rx3I Card
41901	04	GE	IC693MDL645	24 Volt 16 ch Discrete Input Card	REPLACE EXISTING CARD WITH Rx3I Card
41901	08	GE	ICC693ALG222	16 Ch analog Input Card	REPLACE EXISTING CARD WITH Rx3I Card
41901		GE	IC695CHS010	10-slot IO rack	REPLACE EXISTING 10-SLOT RACK
41901		GE	IC695PSD140	24VDC Rack Power Supply 30 WATTS	REPLACE EXISTING RACK POWER SUPPLY

LCP-41101 (new)

SCREENINGS ROOM GAS DETECTOR PANEL BY MSA. REFERENCE P&ID 090-N-004

ITEM	P/N	QTY	DESCRIPTION
1	711169	4	2 SAMPLING MODULE, DC PUMP
2	A-ULTIX-PCB-E-E-3-0-3-0	AR	PCBA, ULTIMA X
3	10040254	2	CALIBRATION, VALVE, PUSHBUTTON
4		1	STACKLIGHT
5	637123	1	BUZZER
6		AR	RELAY/SOCKET, 4PDT, 24 VDC COIL
7		AR	RELAY/SOCKET, 4PDT, 120 VAC COIL
8	813159	4	FLAME ARRESTOR
9	10015787	4	EOL LINE FILTER
10	453895	4	FLOW INDICATOR
11	A-ULIIC-SENS-38-2-0	2	ULTIMA XIR SENSOR, 0-100% LEL
12	P-ULTIMXIR-CAP	AR	XIR FLOW CAP
13	A-ULTX-SENS-17-0-C	2	ULTIMA X SENSOR, 0-100 PPM H2S
14	P-ULTIMAXE-CAP 2	AR	ULTIMAX FLOW CAP
15		1	ACK/RESET, SYSTEM TEST, PUSHBUTTON
16	10040255	1	POWER SUPPLY, 24VDC, 4.5A

GAS DETECTOR PANEL TO DRIVE 3 SETS OF COMBINED HORN/BEACON. 1 AT THE OUTSIDE OF EACH ENTRANCE TO SCREENINGS ROOM, AND ONE INSIDE THE SCREENINGS ROOM.

ITEM	MANUFACTURER	P/N	QTY	DESCRIPTION	TAGS
17	ROCKWELL	855XC-BNA10A4	3	CLASS 1 DIV 2COMBO HORN& BEACON, 120 VAC	YA-41103A, YA-41103B, YA-41103C

CONTROL PANEL SCHEDULE

LCP-42700 (new)

Odor Control Gas Detector panel

ITEM	P/N	QTY	DESCRIPTION
1	711169	1	2 SAMPLING MODULE, DC PUMP
2	A-ULTIX-PCB-E-E-3-0-3-0	AR	PCBA, ULTIMA X
3	10040254	1	CALIBRATION, VALVE, PUSHBUTTON
4		1	STACKLIGHT
5	637123	1	BUZZER
6		AR	RELAY/SOCKET, 4PDT, 24 VDC COIL
7		AR	RELAY/SOCKET, 4PDT, 120 VAC COIL
8	813159	1	FLAME ARRESTOR
9	10015787	1	EOL LINE FILTER
10	453895	1	FLOW INDICATOR
11	A-ULIIC-SENS-38-2-0	1	ULTIMA XIR SENSOR, 0-100% LEL
12	P-ULTIMXIR-CAP	AR	XIR FLOW CAP
13	P-ULTIMAXE-CAP 2	AR	ULTIMAX FLOW CAP
14		1	ACK/RESET, SYSTEM TEST, PUSHBUTTON
15	10040255	1	POWER SUPPLY, 24VDC, 4.5A

City of Wichita

CONSTRUCTION POLLUTION PREVENTION PLAN

SITE DESCRIPTION			
Project Name and Location	Four Mile Creek WQRF Ph2 15800 E Harry St, Wichita, KS	Owner Name and Address	City of Wichita 7th Floor, City Hall 455 North Main Wichita, KS 67202
Project Description: Purpose and Type of Activity	Expansion of existing WQRF from 3 MGD to 6 MGD		
Site Area & Disturbed Area	Total Project Area: 21.5 acres Disturbed Site Area: 8 acres		
Sequence of Major Activities			
<p>Construction of the site will be phased. The first priority during construction will be to construct the new clarifiers on the northeast portion of the site. Construction will then proceed in a counterclockwise process around the site which constructions the new facilities from downstream to upstream in the liquid treatment process. While the contractor will have full control over means and methods on how things will be constructed, the expected phasing is as follows:</p> <ol style="list-style-type: none"> 1. New Outfall, UV/Cascade and Clarifiers. New Electrical Service Entrance and RS (Crestview) Line. 2. New Bioreactor and Splitter Box. Facility 300 and 350 Modifications. 3. New Screening and Odor Control Facility. Influent Pump Station, RS (Crestline) Line final connections. 			
Feature Discharged To	Four Mile Creek		
CONTROL MEASURES			
Erosion and Sediment Control			
Stabilization Practices			
<p>No untested or unapproved BMPs are proposed for the facility. In general, silt fence and straw waddles will be used to prevent sediment from leaving the site. Riprap will be used in areas to permanently stabilize the site, otherwise all disturbed, non-paved areas will be re-seeded and restored.</p>			

Structural Practices

Comply with Section 01 50 00 3.02F Existing Structures:

1. Where Contractor contemplates removal of small structures such as mailboxes, signposts, and culverts that interfere with the Contractor's operations, obtain approval of property owner and Engineer.
2. Move mailboxes to temporary locations accessible to postal service.
3. Replace items removed in their original location and a condition equal to or better than original.

Stormwater Runoff Management

Keep ditches, culverts, and natural drainages continuously free of construction materials and debris.

Comply with Section 01 57 13, Temporary Erosion and Sedimentation control, for stormwater flow and surface runoff. Size temporary stormwater conveyances based on procedures presented in US Dept of Agriculture, Natural Resources Conservation Service: Urban Hydrology for Small Watersheds, 1986. Technical Release 55.

OTHER CONTROL MEASURES

Waste Material Disposal

All waste materials will be collected and stored in a securely lidded metal dumpster. The dumpster will meet all local County and State of Kansas solid waste management regulations. All trash and construction debris from the site will be deposited in the dumpster. The dumpster will be emptied as necessary and trash will be hauled to an appropriate trash facility. No construction waste materials will be buried onsite. All personnel will be instructed regarding the correct procedure for waste disposal. Notices stating these practices will be posted in the office trailer and the individual, who manages the day-to-day operations, will be responsible for seeing that these practices are followed.

Offsite Vehicle Tracking Control

The paved street adjacent to the site entrance will be swept regularly to remove any excess mud, dirt or rock tracked from the site.

See Sections 01 50 00 3.05 Access Roads, 3.06 Parking Areas, 3.07 Vehicular Traffic, and 3.08 Cleaning During Construction for specific procedures.

Concrete Truck Washout

Concrete trucks will be allowed to washout on site provided an appropriate place to do so is established. The washout area will be located in a vacant area, designated by the Contractor. It should consist of a large (~15' X 20') area for the trucks to washout in, surrounded by 2' high soil berms to prevent any washout water from entering the streets, storm water sewer or nearby water bodies. Instead of berms, a 2' deep pit would be acceptable, as long as the washout water is contained. When the washout pit needs to be moved or is no longer needed, the concrete sediment is to be excavated and hauled to an appropriate waste disposal site and the pit area is to be graded to final grade and seeded appropriately.

Hazardous Waste

All hazardous waste materials will be disposed of in the manner specified by local or State regulation or by the manufacturer. Site personnel will be instructed in these practices and the individual, who manages site operations, will be responsible for seeing that these practices are followed.

Sanitary Waste

Divert sanitary sewage and nonstorm waste flow interfering with construction and requiring diversion to sanitary sewers. Do not cause or permit any action to occur which would cause an overflow to existing waterway. For more information about Sanitary Sewer Overflow procedures, see section 107.6 Sanitary Sewer Overflow.

TIMING OF CONTROL MEASURES

The stabilized construction entrance will be constructed prior to clearing or grading of any other portions of the site. Areas where construction activity temporarily ceases for more than 14 days will be stabilized with temporary seed and mulch within 14 days of last disturbance. After the entire site is stabilized, the accumulated sediment will be removed from the silt fence and the silt fence will be removed.

MAINTENANCE/INSPECTION PROCEDURES

Erosion and Sediment Control and Maintenance Practices

Provide, maintain, and operate temporary facilities to control erosion and sediment releases during construction period. Design erosion and sediment controls to handle peak runoff resulting from 25-year, 24-hour storm event based on National Weather Service: Precipitation Frequency Data Server. Size temporary stormwater conveyances based on procedures presented in US Dept of Agriculture, Natural Resources Conservation Service: Urban Hydrology for Small Watersheds, 1986. Technical Release 55.

For specific SWPPP procedures, see Section 01 57 13 Temporary Erosion and Sediment Control and Section 104.3 "Cleanup, Dust Control, Pollution Control, Surface Water and Erosion Control"

Non-Storm Water Discharges

It is expected that the following non-storm water discharges will occur from the site during the construction period:

1. Water from water line flushing. (Section 01 50 00 3.01D Water)
2. Pavement wash waters (where no spills or leaks of toxic or hazardous materials have occurred).
3. Uncontaminated groundwater (from dewatering excavation). (Section 104.1 "Work to be Done")

Inventory for Pollution Prevention Plan

The materials or substances described in Section 01 57 13 Part 2: Products are expected to be present onsite during construction.

Spill Prevention

Material Management Practices

The following are the material management practices that will be used to reduce the risk of spills and other accidental exposure of materials and substances to storm water runoff.

Good Housekeeping: The following good housekeeping practices will be followed onsite during construction of the project:

The following good housekeeping practices will be followed during the construction project.

1. An effort will be made to store only enough product required to do the job.
2. All materials stored onsite will be stored in a neat, orderly manner in their appropriate containers and, if possible, under a roof or other enclosure.
3. Products will be kept in their original container with the original manufacturer's label.
4. Substances will not be mixed with one another unless recommended by the manufacturer.
5. Whenever possible, all of a product will be used up before disposing of the container.
6. Manufacturer's recommendations for proper use and disposal will be followed.
7. The site superintendent will inspect daily to ensure proper use and disposal of materials onsite.
8. Dump trucks hauling excavated material from the site will be loaded to prevent spilling material while in transport.

Hazardous Products: The following practices will be used to reduce the risks associated with hazardous materials:

These practices are used to reduce the risk associated with hazardous materials.

1. Products will be kept in original containers unless they are not resealable.
2. Original labels and material safety data will be retained; they contain important product information.
3. If surplus product must be disposed of, manufacturers or local and State recommended methods for proper disposal will be followed.

Spill Control Practices

Use BMPs to prevent or minimize stormwater exposure to pollutants from spills; vehicle and equipment fueling, maintenance, and storage; other cleaning and maintenance activities; and waste handling activities. These pollutants include fuel, hydraulic fluid, and other oils from vehicles and machinery, as well as debris, leftover paints, solvents, and glues from construction operations. Implement the following BMPs when applicable:

1. Written spill prevention and response procedures.
2. Employee training on spill prevention and proper disposal procedures.
3. Spill kits in all vehicles.
4. Regular maintenance schedule for vehicles and machinery.
5. Material delivery and storage controls.
6. Training and signage.
7. Covered storage area for waste and supplies.

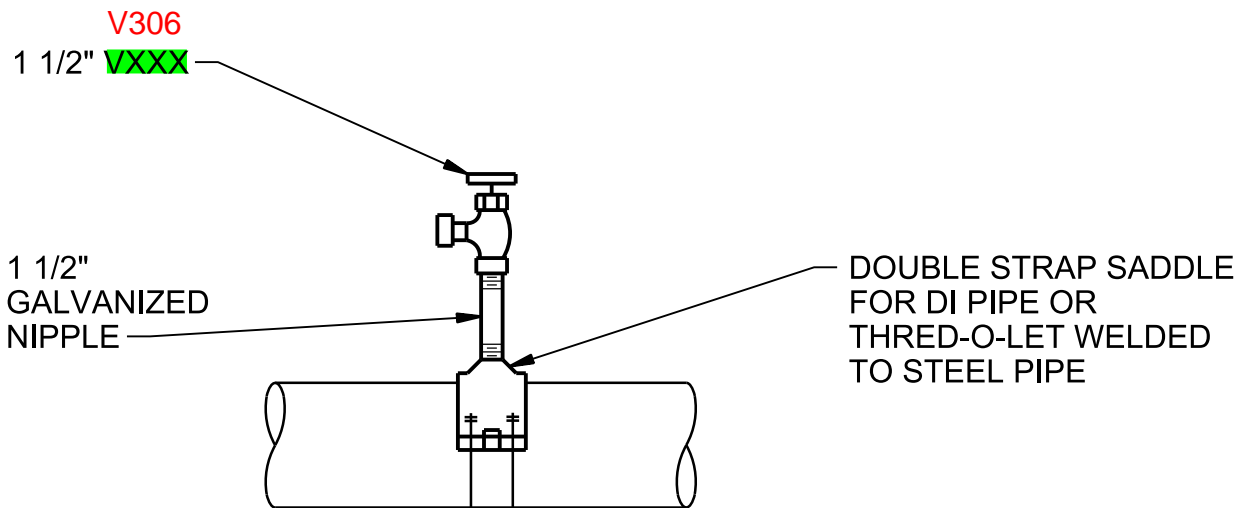

NOTES:

1. ~~TAPPING OF FITTINGS ALLOWED AT BOSS ONLY.~~
SERVICE SADDLES SHALL NOT BE USED ON OUTDOOR EXPOSED PIPE UNLESS OTHERWISE APPROVED BY THE ENGINEER. USE TAPPING BOSS FOR DUCTILE IRON PIPE, OR THREAD-O-LET WELDED TO STEEL OR STAINLESS STEEL PIPE, OR SCHEDULE 80 PVC FITTINGS FOR PVC PIPE.

TYPE 1 FLUSHING CONNECTION

NTS

© CH2M HILL

~~NOTE TO DESIGNER:~~

~~MATCH V-NUMBER TO SPECIFICATIONS~~

4027-181

DATE 30-DEC-84
TDC OLSON
TDR SHOTTS
LCT OLSON



FOLEY GROUP, INC.
333 NORTH 6TH ST.
KANSAS CITY, KS 66101
Phone: 913-342-3336
Contact: Andy Matlock

PHASE II, 6 MGD EXPANSION
FOUR MILE CREEK WQRF
COW PN. 468-84961

LIGHT FIXTURE PACKAGE
EQUAL APPLICATION SUBMITTAL

DECEMBER 9, 2016



FOLEY GROUP, INC.
333 NORTH 6TH ST.
KANSAS CITY, KS 66101
Phone: 913-342-3336
Contact: Andy Matlock

STATEMENT OF VARIATIONS

1. TYPE A1 SUBMITTED WITH CLEAR POLYCARBONATE LENS TO MATCH LUMEN OUTPUT OF SPECIFIED FIXTURE. TYPE A2 SUBMITTED WITH CLEAR POLYCARBONATE LENS TO MATCH TYPE A1 AS SUBMITTED.
2. FIXTURE SUBMITTED FOR TYPE A2 HAS 90° MOUNTING BRACKET. SPECIFIED FIXTURE HAS 45° MOUNTING BRACKET.
3. FIXTURE TYPE EXZ EXIT SIGN IS EDGE-LIT. SPECIFIED FIXTURE IS BACK LIT LED.
4. TYPE ELZ IS SUBMITTED WITH METALLIC HOUSING. SPECIFIED FIXTURE HOUSING IS NON-METALLIC.
5. TYPES L1, L1E, L2, Z1, AND Z1E HAVE VARIATIONS IN OVERALL HEIGHT COMPARED TO SPECIFIED FIXTURES.

OTHER NOTES

1. INSUFFICIENT INFORMATION HAS BEEN PROVIDED FOR TYPE H1 TO ALLOW FOR SELECTION OF ALTERNATE, EQUAL FIXTURE FOR SUBMISSION IN THIS PACKAGE. ADDITIONAL INFORMATION IS REQUESTED (I.E. PART NUMBER, LUMEN PACKAGE, ETC.) IN ORDER TO SELECT AND SUBMIT EQUAL FIXTURE OPTION WITHIN REQUIRED TIME FRAME.
2. PLEASE CONFIRM MOUNTING FOR TYPE A1. SCHEDULE LISTS MOUNTING AS "PENDANT" BUT NOTES INCLUDE DESCRIPTION OF "45 DEGREE WALL MOUNT".

Lighting Systems



SAFJ LED

LED area lighting for hazardous locations



Key Features

- Low profile and compact design
- Wide distribution pattern with uplight
- Field replaceable LED circuit boards and drivers with quick disconnects
- Hinged mount for access to internal components
- Clear or diffused lens options
- No external fins

Additional Features

- Supplemental 10kV surge protection
- Pendant, ceiling, wall and stanchion mounting options
- Terminal block
- Mates directly to select competitor mounts
- Optional stainless steel threaded inserts
- Dimming option
- Optional stainless steel guard
- 5-year warranty

Classifications

- Class I, Division 2, Groups A, B, C, and D
- Class II, Division 1 & 2, Groups E, F and G
- Class III
- UL 1598A Marine Outside Type
- UL 1598 Wet Locations
- UL 844 Hazardous Locations
- UL 8750 LED Safety
- ABS Type Approved
- Tested to LM 79 & LM 80
- 55° C Ambient Temperature
- Simultaneous Presence
- US Patent # D637,340S
- NEMA 4X
- IP66
- CUL
- DLC Listed

Standard Materials

Body: A360 aluminum (less than .4% copper content) with baked-on gray epoxy finish

Gaskets: One-piece silicone

Lens: Borosilicate Glass or Polycarbonate

Hardware: Stainless Steel



Certification Guide

Model	Mount	Wattage	Operating Voltage	Total Lumens	Lumens per Watt	CRI	CCT	Ambient Temperature	Class I, Div. 2, Group A, B, C & D	Class II, Div. 1 & 2 Group E, F & G Class III	Simultaneous Presence	Supply Wire Suitable Temperature, °C
SAFJ03L2LC	P, C, W, S, L	30W	120V - 277V 50/60 Hz, 347V/480V 60Hz	3059	109	74	4766	-20°C < Tamb < 50°C	T3C	T5	T3	90°C
SAFJ03L2LF	P, C, W, S, L	30W		2752	97	73	4778	-20°C < Tamb < 50°C	T3C	T5	T3	90°C
SAFJ06L2LC	P, C, W, S, L	50W		4806	100	74	4785	-20°C < Tamb < 50°C	T3C	T3A	T3	90°C
SAFJ06L2LF	P, C, W, S, L	50W		4136	86	74	4734	-20°C < Tamb < 50°C	T3C	T3A	T3	90°C
SAFJ06L2LPC	P, C, W, S, L	50W		4671	97	74	4804	-20°C < Tamb < 50°C	T3C	T3A	T3	90°C
SAFJ06L2LPCF	P, C, W, S, L	50W		3123	65	77	4571	-20°C < Tamb < 50°C	T3C	T3A	T3	90°C

SAFJ 06 - L2 - U - LFG - C - XX



1

SERIES
SAFJ LED

2

LAMP CURRENT/LAMP WATTAGE

03 = 30 Watts
06 = 50 Watts

3

LAMP TYPE
L2 = LED

4

DRIVER VOLTAGE
U = 120-277V 50/60HZ
N = 347/480V 60HZ

5

GLOBE & GUARD

LC = Low Profile Clear Globe
LCG = Low Profile Clear Globe & Guard
LPC = Low Profile Clear Polycarbonate
LPCG = Low Profile Clear Polycarbonate & Guard
LF = Low Profile Frosted Globe
LFG = Low Profile Frosted Globe & Guard
LPF = Low Profile Frosted Polycarbonate Globe
LPFG = Low Profile Frosted Polycarbonate Globe & Guard

6

MOUNTING STYLE

P = 3/4" Pendant Mount
PI = 1" Pendant Mount
C = 3/4" Ceiling Mount
CI = 1" Ceiling Mount
W = 3/4" Wall Mount
WI = 1" Wall Mount
S = 1-1/4" 25° Stanchion Mount
SI = 1-1/2" 25° Stanchion Mount
L = 1-1/4" 90° Stanchion Mount
LI = 1-1/2" 90° Stanchion Mount

7

OPTIONS¹

SS = Stainless Steel Inserts
FB1 = Single Fuse Block ^{2,3}
FB2 = Double Fuse Block ^{2,3}

1 Consult factory for pricing.
2 Not available with universal driver unless incoming voltage is specified. When installed, one fuse block is provided for 120 & 277V and two fuse blocks are provided for 208, 220, 240, 347 and 480V. Fuse not provided.
3 FB option not available for marine listed fixtures.

Part numbering logic is for explaining part number structure only. Not all combinations are possible; consult factory for catalog numbers not listed on chart.

Lighting Systems



SAFJ LED

LED area lighting for hazardous locations



Key Features

- Low profile and compact design
- Wide distribution pattern with uplight
- Field replaceable LED circuit boards and drivers with quick disconnects
- Hinged mount for access to internal components
- Clear or diffused lens options
- No external fins

Additional Features

- Supplemental 10kV surge protection
- Pendant, ceiling, wall and stanchion mounting options
- Terminal block
- Mates directly to select competitor mounts
- Optional stainless steel threaded inserts
- Dimming option
- Optional stainless steel guard
- 5-year warranty

Classifications

- Class I, Division 2, Groups A, B, C, and D
- Class II, Division 1 & 2, Groups E, F and G
- Class III
- UL 1598A Marine Outside Type
- UL 1598 Wet Locations
- UL 844 Hazardous Locations
- UL 8750 LED Safety
- ABS Type Approved
- Tested to LM 79 & LM 80
- 55° C Ambient Temperature
- Simultaneous Presence
- US Patent # D637,340S
- NEMA 4X
- IP66
- CUL
- DLC Listed

Standard Materials

Body: A360 aluminum (less than .4% copper content) with baked-on gray epoxy finish

Gaskets: One-piece silicone

Lens: Borosilicate Glass or Polycarbonate

Hardware: Stainless Steel



Certification Guide

Model	Mount	Wattage	Operating Voltage	Total Lumens	Lumens per Watt	CRI	CCT	Ambient Temperature	Class I, Div. 2, Group A, B, C & D	Class II, Div. 1 & 2 Group E, F & G Class III	Simultaneous Presence	Supply Wire Suitable Temperature, °C
SAFJ03L2LC	P, C, W, S, L	30W	120V - 277V 50/60 Hz, 347V/480V 60Hz	3059	109	74	4766	-20°C < Tamb < 50°C	T3C	T5	T3	90°C
SAFJ03L2LF	P, C, W, S, L	30W		2752	97	73	4778	-20°C < Tamb < 50°C	T3C	T5	T3	90°C
SAFJ06L2LC	P, C, W, S, L	50W		4806	100	74	4785	-20°C < Tamb < 50°C	T3C	T3A	T3	90°C
SAFJ06L2LF	P, C, W, S, L	50W		4136	86	74	4734	-20°C < Tamb < 50°C	T3C	T3A	T3	90°C
SAFJ06L2LPC	P, C, W, S, L	50W		4671	97	74	4804	-20°C < Tamb < 50°C	T3C	T3A	T3	90°C
SAFJ06L2LPCF	P, C, W, S, L	50W		3123	65	77	4571	-20°C < Tamb < 50°C	T3C	T3A	T3	90°C

SAFJ 06 - L2 - U - LFG - C - XX



1

SERIES
SAFJ LED

2

LAMP CURRENT/LAMP WATTAGE
03 = 30 Watts
06 = 50 Watts

3

LAMP TYPE
L2 = LED

4

DRIVER VOLTAGE
U = 120-277V 50/60HZ
N = 347/480V 60HZ

5

GLOBE & GUARD
LC = Low Profile Clear Globe
LCG = Low Profile Clear Globe & Guard
LPC = Low Profile Clear Polycarbonate
LPCG = Low Profile Clear Polycarbonate & Guard
LF = Low Profile Frosted Globe
LFG = Low Profile Frosted Globe & Guard
LPF = Low Profile Frosted Polycarbonate Globe
LPFG = Low Profile Frosted Polycarbonate Globe & Guard

6

MOUNTING STYLE
P = 3/4" Pendant Mount
PI = 1" Pendant Mount
C = 3/4" Ceiling Mount
CI = 1" Ceiling Mount
W = 3/4" Wall Mount
WI = 1" Wall Mount
S = 1-1/4" 25° Stanchion Mount
SI = 1-1/2" 25° Stanchion Mount
L = 1-1/4" 90° Stanchion Mount
LI = 1-1/2" 90° Stanchion Mount

7

OPTIONS¹
SS = Stainless Steel Inserts
FB1 = Single Fuse Block ^{2,3}
FB2 = Double Fuse Block ^{2,3}

1 Consult factory for pricing.
2 Not available with universal driver unless incoming voltage is specified. When installed, one fuse block is provided for 120 & 277V and two fuse blocks are provided for 208, 220, 240, 347 and 480V. Fuse not provided.
3 FB option not available for marine listed fixtures.

Part numbering logic is for explaining part number structure only. Not all combinations are possible; consult factory for catalog numbers not listed on chart.

HLEX SERIES

Hazardous Location Edge Lit LED Exit Light

- Class I, Division 2, Groups A, B, C & D
- Class II, Division 2, Groups F & G
- Class III
- UL 1598A Marine Outside Type
- Temperature Class (T-Rating)-T6
- Patent No. 7,287,347
- IP65
- ETL Listed



H
L
E
X



AZZ | R-A-L™
RIG-A-LITE

HLEX SERIES

Hazardous Location LED Edge Lit Exit Light

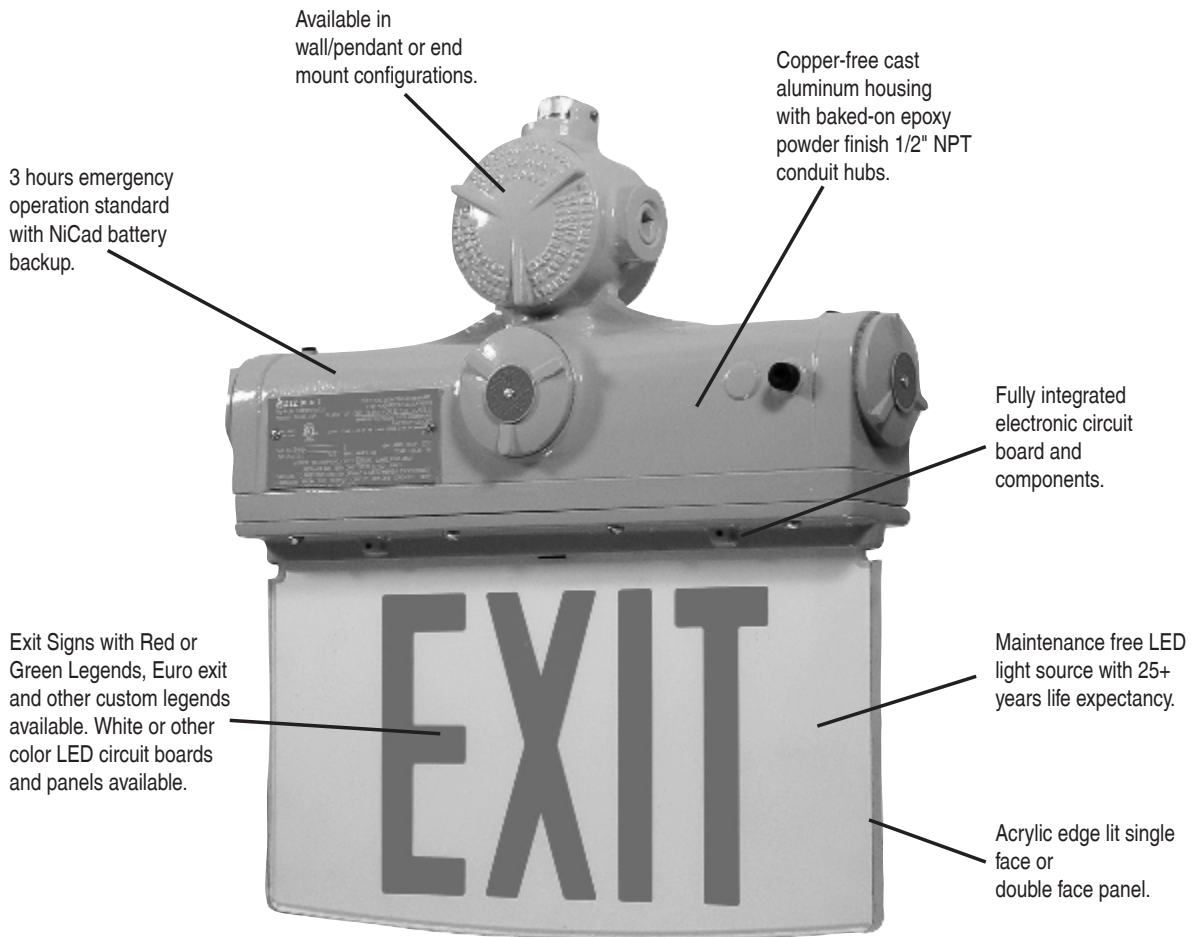

Patent Number 7,287,347

HLEX series fixture uses a maintenance free LED light source with a 25 year life expectancy. Emergency fixtures meet or exceed NFPA70, NFPA101, EPA Energy Star and OSHA requirements. These fixtures are also suitable for installation in wet or damp locations where salt water spray is possible.



LED

HLEX Series

Hazardous Locations • Class I, Division 2 • UL 844 • UL 1598A • UL 8750 • Wet Locations • IP65

Catalog Number Logic

HLEX

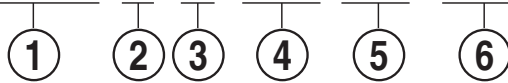

1 **BASIC SERIES**
 HLEX Explosion Proof LED Exit Light
 Class I, Division 2, Groups A, B, C, & D
 Class II, Division 2, Groups F & G
 Class III
 UL 1598A Marine Outside Type
 IP65
 ETL Listed
 Temperature Class (T-Rating)-T6

2 **NUMBER OF FACES**
 1 = Single Face
 2 = Double Face

3 **LEGEND COLOR**
 R = Red
 G = Green

4 **VOLTAGE/FREQUENCY**
 DT = 120/277V 60 HZ
 24 = 220-240V 50/60 HZ
 Other voltages available- consult factory.

5 **MOUNTING**
 WP= Wall/Pendant Mounting
 EB = End Bracket

6 **OPTIONS¹**
 EM = Emergency Battery Backup
 EU = Green Running Man Exit Legend
 SD = Self Diagnostics
 X = Exit Legend in Other Languages
 Language Must be Specified

¹Consult factory for pricing.

Maximum Input Power

Red no battery- 1.5 Watts
 Red with battery- 2.5 Watts
 Green no battery- 2.3 Watts
 Green with battery- 3 Watts

Operating Temperature Range

Temperature Rating- T6
 Red Legend
 +10° C Minimum to +55° C Maximum
 Green Legend
 +10° C Minimum to +40° C Maximum

Catalog logic is for explaining catalog number structure only. Not all combinations are possible; consult factory for catalog numbers not listed in charts.

LED
HLEX Series

Hazardous Locations • Class I, Division 2 • UL 844 • UL 1598A • UL 8750 • Wet Locations • IP65

HLEX Series Fixture Dimensions (inches)

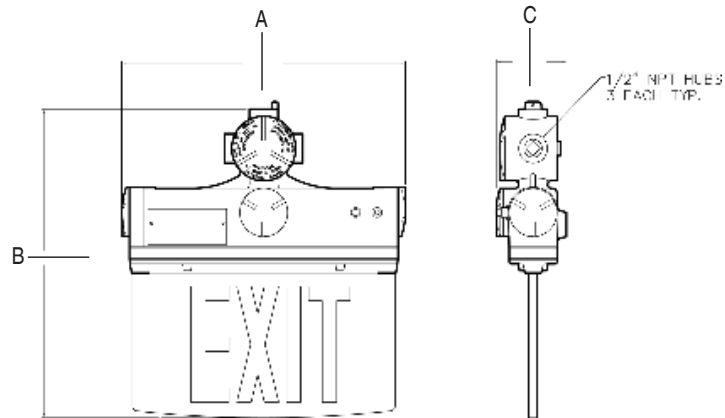

HLEX SERIES	Dimensions (inches)			Boxed Weight	Shipping Volume (Boxed Fixtures)
	A	B	C		
HLEX LED Exit Sign	14.88	16.00	3.69	14 lbs.	1.24 cu. ft.

XPEL LED SERIES

Explosion Proof LED Emergency Light

- Class I, Division 1, Groups C & D
- Class II, Division 1, Groups E, F & G
- Class III
- Class I, Zone 1, Groups IIA, IIB
- UL 844, 1598, 8750 & 924
- UL 1598A Marine Outside Type (Salt Water)
- USCG Regulation 46 CFR Subparts 111.75-15 (e) & 112.43
- CUL
- IP65
- NEMA 4X
- Suitable for Wet Locations
- Patent Pending



XPEL
LED



XPEL SERIES

Explosion Proof LED Emergency Light

Key Features:

- 1 High lumen spot lights (2) can be adjusted in horizontal and vertical planes
- 2 Unit can power up to 2 (optional) remote spot lights
- 3 Field replaceable LED circuit boards and drivers with quick disconnects
- 4 Emergency battery back-up integral to luminaire (no additional enclosure required)
- 5 3-hour emergency operation

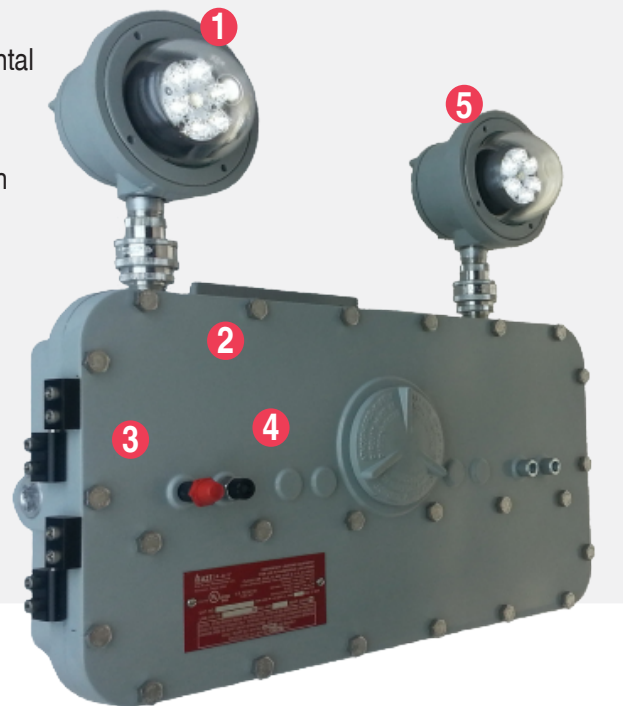

Additional Features:

- Wall, pendant and end mounting options
- Captive hinged-access door
- Wide- and narrow-beam optics available
- Separate push-to-test and pilot light for local and remote heads
- Provided with three (3) 1" NPT hubs

Standard Materials:

- Body: A360 aluminum (less than .4% copper content) with baked-on gray epoxy finish
- Gasket: One-piece neoprene
- Hardware: Stainless steel



LED XPEL Series

Explosion Proof • UL 844 • UL 1598 • UL 8750 • UL 924 • UL 1598A Marine Outside Type • CUL

Catalog Number Logic

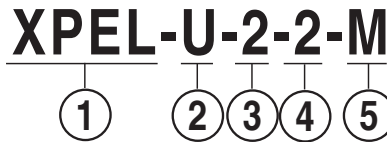

- 1** BASIC SERIES
XPEL
Class I, Division 1, Groups C & D
Class II, Division 1, Groups E, F & G
Class III
Class I, Zone 1, Groups IIA, IIB,
UL 844, 1598, 8750 & 924
UL 1598A Marine Outside Type (Salt Water)
USCG Regulation 46 Sub Part 111.75-15(e) & 112.43
CUL
IP65
NEMA 4X
Suitable for Wet Locations

- 2** VOLTAGE / FREQUENCY
U = 120 thru 277V 50/60HZ

- 3** INSTALLED HEADS
0 = None
1 = One
2 = Two

- 4** REMOTE HEADS¹
0 = None
1 = One
2 = Two
3 = Three
4 = Four

- 5** OPTIONS²
M = Medium Beam Optics (STANDARD)
N = Narrow Beam Optics
W = Wide Beam Optics

Combinations Available		
Installed	Remote	Drivers
2	0	1
1	1	1
0	2	1
2	2	2
1	3	2
0	4	2

¹XPEL Series emergency lights with remote head option are provided with extra LED driver. Remote heads can only be wired to the emergency fixtures with remote head option. LED heads are furnished with 1/2"-14 NPT male hub, must be installed on suitably listed explosion proof junction box not provided by RAL.

²Consult factory for pricing.

Maximum Input Power

XPEL Emergency Light with:

- 2 LED heads - 4 W
- 4 LED heads - 8 W

Maximum Output Data

Each Remote Head:

- Voltage: 22V DC. max.
- Current: 0.225 A (225mA)
- Max. Power: 5 W

Certification Guide

XPEL Series Emergency Light	Ambient Temperature Range	Class I, Division 1 Groups C & D	Class II, Division 1 Groups E, F & G Class III	Simultaneous Presence Class I & II	UL 1598A Marine	CUL
XPEL	+10° C to +55° C	T6	T6	T6	Yes	Yes



Project
MGD EXPANSION

Catalog Number
XPEL-U-2-0-M

Type
ELZ

Notes

LED XPEL Series

Explosion Proof • UL 844 • UL 1598 • UL 8750 • UL 924 • UL 1598A Marine Outside Type • CUL

Photometric Data

XPEL LED head with medium beam optics:

Total Lumens per Head	420.78
Output Power per Head	4.83
Efficacy (Lumens/Watts)	87.12
CRI	72
CCT	5672

Average Initial Footcandles at the Floor	1.49
Maximum Initial Footcandles at the Floor	2.80
Minimum Initial Footcandles at the Floor	0.50
Maximum to Minimum Ratio	5.60

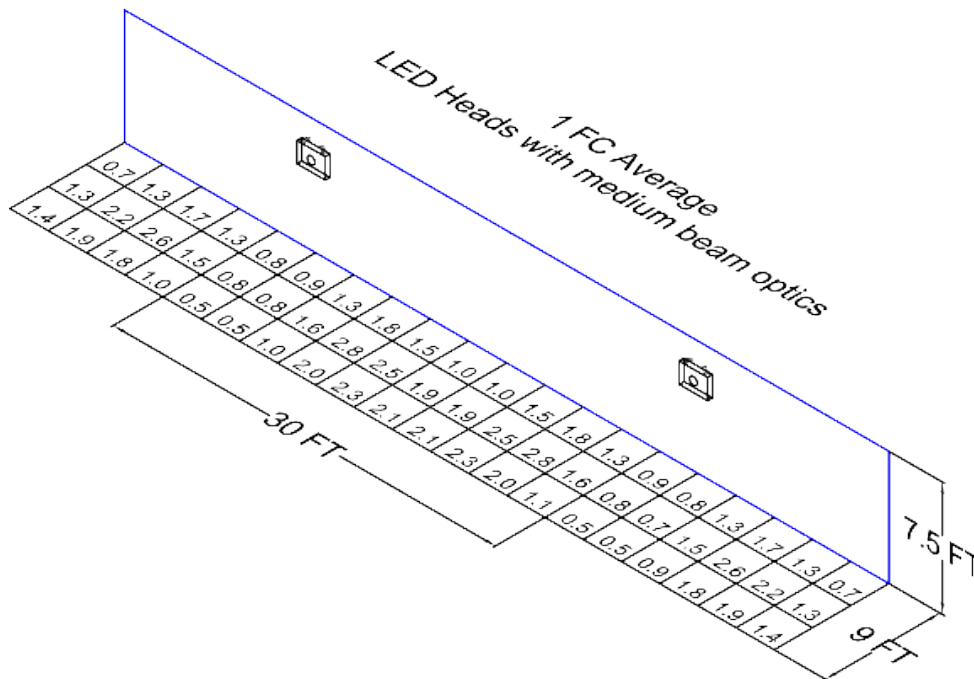



Project
MGD EXPANSION

Catalog Number
XPEL-U-2-0-M

Type
ELZ

Notes

LED XPEL Series

Explosion Proof • UL 844 • UL 1598 • UL 8750 • UL 924 • UL 1598A Marine Outside Type • CUL

XPEL Series Fixture Dimensions (inches)

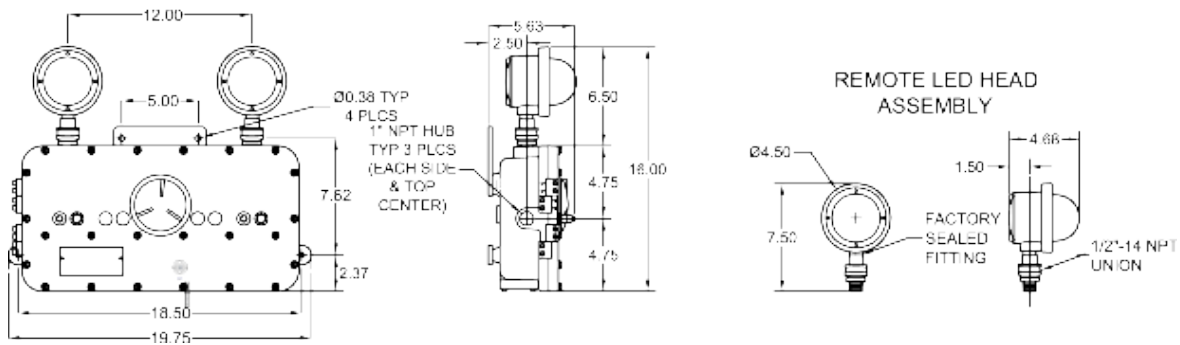

XPEL SERIES	Shipping Weight	Shipping Volume
Emergency Light	35.0 lbs.	2.2 cu. ft.
Emergency Light with Remote Heads Option*	38.0 lbs.	2.2 cu. ft.
Remote Head Assembly	3.5 lbs.	0.27 cu. ft.

* Remote Head Assemblies are shipped separately.
(Additional weight of the emergency light is due to extra driver for remote heads.)



Project
MGD EXPANSION

Catalog Number
ML07-L-C-4-U-MB

Type
L1

Notes

ML LED

Linear LED Lighting for Harsh Environments

- UL 1598A Marine Outside Type
- UL 1598 Wet Location
- UL 8750 LED Safety
- UL 924 Emergency Lighting
- -40°C to 65°C Ambient Temperature
- CSA C22.2 No. 250.0-08
- NEMA 4X
- CE
- IP66
- Tested to LM 79 & LM 80



ML
LED



713.943.0340 | azz.com/rigalite

ML LED

Linear LED Lighting for Harsh Environments

Key Features:

- 1 Low-profile, lightweight design
- 2 Heavy-duty, 3/8" thick die-cast safety cable attachment points
- 3 Tool-less, cage-clamp terminal block, standard
- 4 Captive junction box cover, attached by nylon-coated stainless steel cable
- 5 Field replaceable LED circuit boards and drivers with quick disconnects
- 6 Adjustable mounting bracket with 60° range of motion and nine locking positions*
- 7 Impact resistant clear lens

* Not included, must be ordered separately. Please see options section.

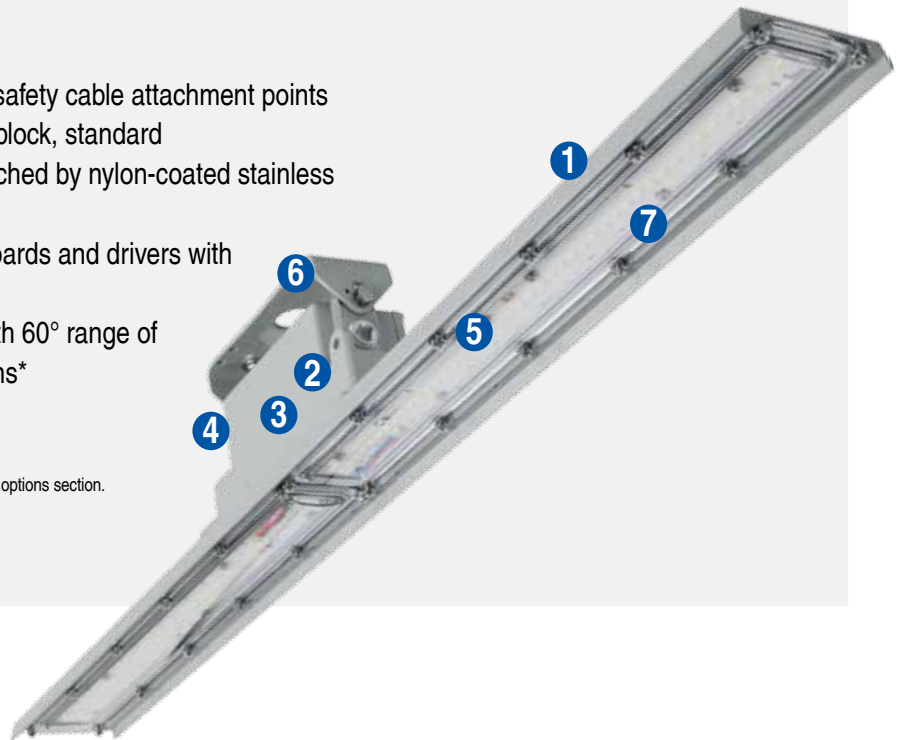

Additional Features:

- Central safety cable attachment points for increased safety/reduced range of motion
- Feed-through capable
- Optional end brackets for chain mount applications
- Emergency battery back-up
- Diffused lens option
- 10 kV standard surge protection
- 5-year warranty

Standard Materials:

- Body: 6061T5 aluminum (less than .4% copper content) with baked-on gray epoxy finish
- Driver body: A360 aluminum (less than .4% copper content) with baked-on gray epoxy finish
- Gaskets: one-piece neoprene
- Optional end brackets: stainless steel
- Lens: polycarbonate
- Hardware: stainless steel



Project
MGD EXPANSION

Catalog Number
ML07-L-C-4-U-MB

Notes

Type
L1

LED ML

Linear LED Lighting for Harsh Environments

Catalog Number Logic

ML 07 - L - C - 4 - U - XX

① ② ③ ④ ⑤ ⑥ ⑦

1 BASIC LUMINAIRE
ML = Harsh Environment Linear LED¹
CEML = CE LED

2 LAMP WATTAGE
07 = 80 Watt (4 foot)
04 = 40 Watt (2 foot)

3 LAMP TYPE
L = LED (4000K CCT)

4 LENS
C = Clear
D = Diffused

5 NOMINAL FIXTURE LENGTH
2 = 2 Foot
4 = 4 Foot

6 VOLTAGE/ FREQUENCY
U = 120 - 277V 50/60HZ
N = 347/480V 60HZ
A = 120V 60HZ²
B = 220 - 240V 50/60HZ²
C = 277V 60HZ²

7 OPTIONS
RIG = Mounting Bracket & (2) Safety Cables
MB = Mounting Bracket Ceiling or Wall
EB = End Brackets Cable or Chain Suspension
HA = High Ambient 65°C Rated (4 ft. Model Only)
EM = Emergency Battery Backup
SP = Increased Surge Protection, 10kV (Not available with 347/480V)
FB = Fuse Block (Not Available with 347/480V)²
SC = Safety Cable
30 = 3000K CCT
35 = 3500K CCT
50 = 5000K CCT

¹Mounting Hardware not included. Please see options for mounting selections.

²Specify voltage when option FB is needed. When option FB is selected, one fuse is provided for 120 and 277V. Two fuses are provided for 220-240V. Fuse option not available for marine listed fixtures, or for fixtures listed for use in Canada.



Project
MGD EXPANSION

Catalog Number
ML07-L-C-4-U-MB

Type
L1

Notes

LED
ML

Linear LED Lighting for Harsh Environments

Certification Guide

Model	Length	Wattage	Operating Voltage	Total Lumens	Lumen per Watt	CRI	CCT	Ambient Temperature	Supply Wire Suitable Temperature, °C
ML04LC2	2 ft	40W	120V - 277V 50/60 Hz,	4068	101	84	4009	-40°C < Tamb < 55°C	90°C
ML07LC4	4 ft	80W	347V/480V 60Hz	7654	102	84	4105	-35°C < Tamb < 60°C	90°C
ML04LD2	2 ft	40W	120V - 277V 50/60 Hz,	3737	93	83	3916	-40°C < Tamb < 55°C	90°C
ML07LD4	4 ft	80W	347V/480V 60Hz	7453	99	83	4034	-35°C < Tamb < 60°C	90°C
ML07LC4-HA	4 ft	80W	120V - 277V 50/60 Hz,	7654	102	84	4105	-30°C < Tamb < 65°C	90°C
ML07LD4-HA	4 ft	80W	347V/480V 60Hz	7453	99	83	4034	-30°C < Tamb < 65°C	90°C

ML07LC4U

Coefficients of Utilization

% Effective Ceiling Cavity Reflectance rcc	80				70				50				30				10				0
	70	50	30	10	70	50	30	10	50	30	10	50	30	10	50	30	10	50	30	10	0
Room Cavity Ratio RCR	Effective Floor Cavity Reflectance 20%																				
0	119	119	119	119	116	116	116	116	111	111	111	111	106	106	106	102	102	102	102	100	
1	110	105	101	98	107	103	99	96	99	96	93	95	92	90	91	89	88	85	85	85	
2	100	92	86	80	98	90	84	79	87	82	78	84	79	76	81	77	74	72	74	72	
3	91	81	74	67	89	80	73	67	77	71	65	74	69	64	72	67	63	61	63	61	
4	84	72	64	57	82	71	63	57	68	61	56	66	60	55	64	59	54	52	54	52	
5	77	65	56	49	75	63	55	49	61	54	48	59	53	48	58	52	47	45	47	45	
6	71	58	49	43	69	57	49	43	55	48	42	54	47	42	52	46	42	40	42	40	
7	66	53	44	38	64	52	44	38	50	43	38	49	42	37	48	42	37	35	37	35	
8	61	48	40	34	60	47	39	34	46	39	34	45	38	33	44	38	33	31	33	31	
9	57	44	36	31	56	44	36	30	42	35	30	41	35	30	40	34	30	28	30	28	
10	54	41	33	28	53	40	33	28	39	32	27	38	32	27	37	31	27	25	27	25	

Candlepower Distribution

Deg.	0	15	30	45	60	75	90
0	2823	2823	2823	2823	2823	2823	2823
15	2729	2710	2712	2720	2722	2718	2719
25	2514	2529	2533	2537	2537	2514	2540
35	2259	2262	2262	2270	2270	2275	2282
45	1868	1879	1888	1910	1930	1915	1923
55	1400	1405	1418	1444	1460	1444	1449
65	748	737	821	901	934	965	972
75	117	164	450	367	337	381	403
85	29	29	30	32	35	45	56
95	0	0	0	0	0	30	35
105	0	0	0	0	0	0	0

Photometric Data

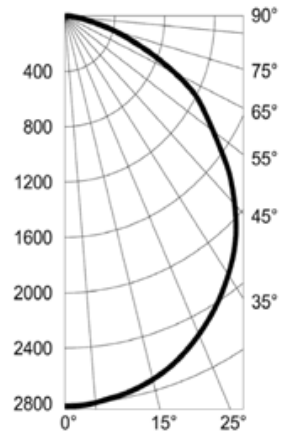

ML04LC2U

Coefficients of Utilization

% Effective Ceiling Cavity Reflectance rcc	80				70				50				30				10				0
	70	50	30	10	70	50	30	10	50	30	10	50	30	10	50	30	10	50	30	10	0
Room Cavity Ratio RCR	Effective Floor Cavity Reflectance 20%																				
0	119	119	119	119	116	116	116	116	111	111	111	111	106	106	106	102	102	102	102	100	
1	109	104	100	96	106	102	98	94	98	94	91	94	91	89	90	88	86	84	86	84	
2	99	91	84	78	96	89	83	77	85	80	76	82	78	74	79	75	72	70	72	70	
3	90	80	72	65	88	78	71	65	75	69	64	73	67	62	70	65	61	59	61	59	
4	83	71	62	56	81	70	61	55	67	60	54	65	59	54	63	57	53	51	53	51	
5	76	63	55	48	74	62	54	48	60	53	47	58	52	47	56	51	46	44	46	44	
6	70	57	48	42	69	56	48	42	54	47	41	53	46	41	51	45	41	39	41	39	
7	65	52	43	37	64	51	43	37	50	42	37	48	41	36	47	41	36	34	36	34	
8	61	47	39	33	59	47	39	33	45	38	33	44	38	33	43	37	32	31	33	31	
9	57	44	35	30	56	43	35	30	42	35	30	41	34	30	40	34	29	28	30	28	
10	53	40	32	27	52	40	32	27	39	32	27	38	31	27	37	31	27	25	27	25	

Candlepower Distribution

Deg.	0	15	30	45	60	75	90
0	1445	1445	1445	1445	1445	1445	1445
15	1395	1396	1393	1401	1394	1397	1401
25	1308	1309	1305	1313	1308	1311	1311
35	1176	1173	1174	1180	1175	1174	1175
45	998	999	1006	998	995	996	998
55	749	759	773	781	774	771	771
65	505	510	502	501	489	495	499
75	221	215	211	222	198	177	133
85	34	34	13	11	9	8	8
95	13	10	9	8	7	7	7
105	12	0	0	0	0	0	0
115	11	0	0	0	0	0	0

Photometric Data

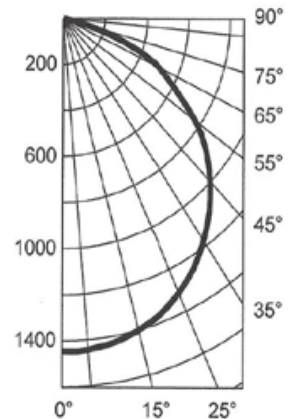



LED ML

Linear LED Lighting for Harsh Environments

ML07LD4U

Coefficients of Utilization

% Effective Ceiling Cavity Reflectance rcc	80				70				50				30				10				0
	70	50	30	10	70	50	30	10	70	50	30	10	70	50	30	10	70	50	30	10	0
Room Cavity Ratio RCR	Effective Floor Cavity Reflectance 20%																				
0	119	119	119	119	116	116	116	116	111	111	111	111	106	106	106	106	102	102	102	102	100
1	109	104	100	96	106	102	98	94	98	94	91	94	91	89	90	88	86	86	86	86	84
2	99	91	84	78	96	89	83	77	85	80	76	82	78	74	79	75	72	72	72	72	70
3	90	80	72	65	88	78	71	65	75	69	64	73	67	62	70	65	61	59	59	59	57
4	83	71	62	56	81	70	61	55	67	60	54	65	59	54	63	57	53	51	51	51	51
5	76	63	55	48	74	62	54	48	60	53	47	58	52	47	56	51	46	44	44	44	44
6	70	57	48	42	69	56	48	42	54	47	41	53	46	41	51	45	41	39	39	39	39
7	65	52	43	37	64	51	43	37	50	42	37	48	41	36	47	41	36	34	34	34	34
8	61	47	39	33	59	47	39	33	45	38	33	44	38	33	43	37	32	31	31	31	31
9	57	44	35	30	56	43	35	30	42	35	30	41	34	30	40	34	29	28	28	28	28
10	53	40	32	27	52	40	32	27	39	32	27	38	31	27	37	31	27	25	25	25	25

Candlepower Distribution

Deg.	0	15	30	45	60	75	90
0	2836	2836	2836	2836	2836	2836	2836
15	2687	2679	2682	2683	2679	2672	2671
25	2424	2427	2428	2430	2424	2415	2414
35	2098	2094	2093	2090	2084	2072	2070
45	1715	1713	1710	1700	1694	1679	1679
55	1317	1313	1309	1295	1280	1264	1260
65	928	925	920	909	889	868	859
75	498	502	501	494	478	455	440
85	77	80	88	96	98	103	93
95	0	0	0	0	0	26	27
105	0	0	0	0	0	0	0

Photometric Data

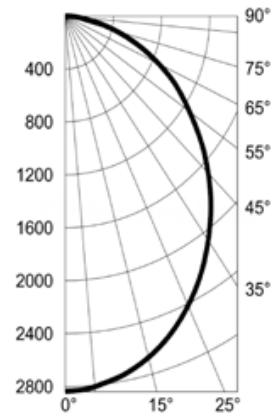

ML04LD2U

Coefficients of Utilization

% Effective Ceiling Cavity Reflectance rcc	80				70				50				30				10				0
	70	50	30	10	70	50	30	10	70	50	30	10	70	50	30	10	70	50	30	10	0
Room Cavity Ratio RCR	Effective Floor Cavity Reflectance 20%																				
0	119	119	119	119	116	116	116	116	111	111	111	111	106	106	106	106	102	102	102	102	100
1	109	104	99	96	106	101	98	94	97	94	91	93	91	88	90	87	85	83	83	83	83
2	99	90	84	78	96	89	82	77	85	80	75	82	77	73	78	75	72	69	69	69	69
3	90	79	71	65	88	78	70	64	75	68	63	72	66	62	69	65	61	58	58	58	58
4	82	70	62	55	80	69	61	54	67	59	54	64	58	53	62	57	52	50	50	50	50
5	76	63	54	48	74	62	53	47	60	52	46	58	51	46	56	50	45	43	43	43	43
6	70	57	48	41	68	56	47	41	54	46	41	52	45	40	51	45	40	38	38	38	38
7	65	51	43	37	63	51	42	36	49	42	36	48	41	36	46	40	36	34	34	34	34
8	61	47	39	33	59	46	38	33	45	38	32	44	37	32	42	36	32	30	30	30	30
9	57	43	35	29	55	43	35	29	41	34	29	40	34	29	39	33	29	27	27	27	27
10	53	40	32	27	52	39	32	27	38	31	27	37	31	26	36	31	26	24	24	24	24

Candlepower Distribution

Deg.	0	15	30	45	60	75	90
0	1373	1373	1373	1373	1373	1373	1373
15	1303	1304	1304	1311	1306	1309	1312
25	1183	1185	1187	1195	1192	1196	1198
35	1021	1021	1027	1035	1037	1041	1043
45	827	831	842	850	856	861	863
55	624	631	646	656	664	670	672
65	423	432	448	460	467	471	472
75	229	239	254	263	268	269	270
85	54	64	64	59	60	62	64
95	11	11	10	8	7	7	6
105	0	0	0	0	0	0	0

Photometric Data

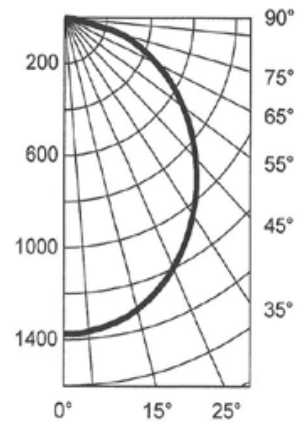



Project
MGD EXPANSION

Catalog Number
ML07-L-C-4-U-MB

Type
L1

Notes

LED ML

Linear LED Lighting for Harsh Environments

Fixture Dimensions (inches)

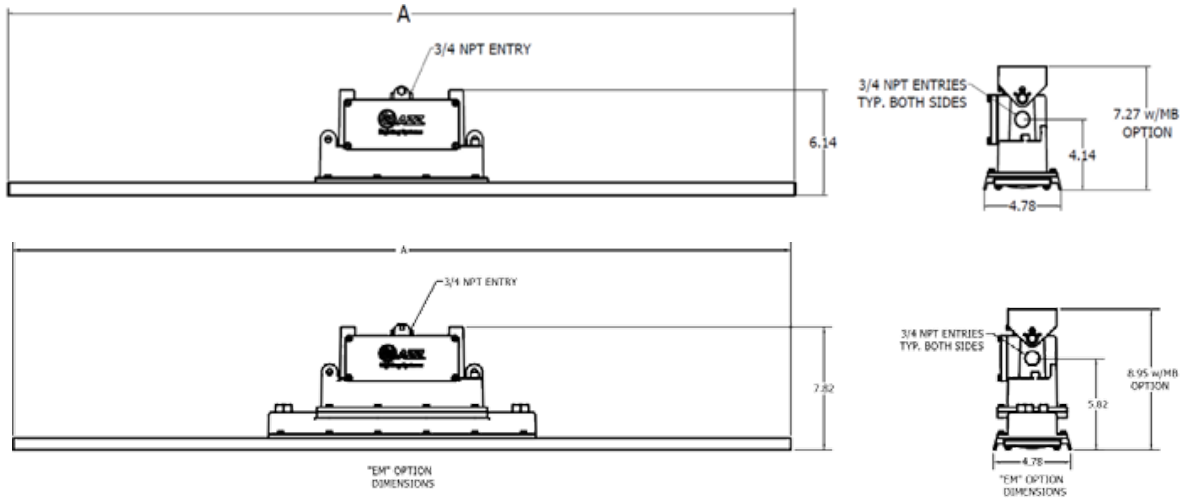

ML SERIES	Dimensions (inches)	Boxed Weight	Shipping Volume
	A		
4 ft. models	48.00	18 lbs.	1.47 cu. ft.
2 ft. models	24.00	10 lbs.	.76 cu. ft.

Accessories





Project
MGD EXPANSION

Catalog Number
ML07-L-C-4-U-MBEM

Type
L1E

Notes

ML LED

ML
LED

Linear LED Lighting for Harsh Environments

- UL 1598A Marine Outside Type
- UL 1598 Wet Location
- UL 8750 LED Safety
- UL 924 Emergency Lighting
- -40°C to 65°C Ambient Temperature
- CSA C22.2 No. 250.0-08
- NEMA 4X
- CE
- IP66
- Tested to LM 79 & LM 80



713.943.0340 | azz.com/rigalite

ML LED

Linear LED Lighting for Harsh Environments

Key Features:

- 1 Low-profile, lightweight design
- 2 Heavy-duty, 3/8" thick die-cast safety cable attachment points
- 3 Tool-less, cage-clamp terminal block, standard
- 4 Captive junction box cover, attached by nylon-coated stainless steel cable
- 5 Field replaceable LED circuit boards and drivers with quick disconnects
- 6 Adjustable mounting bracket with 60° range of motion and nine locking positions*
- 7 Impact resistant clear lens

* Not included, must be ordered separately. Please see options section.

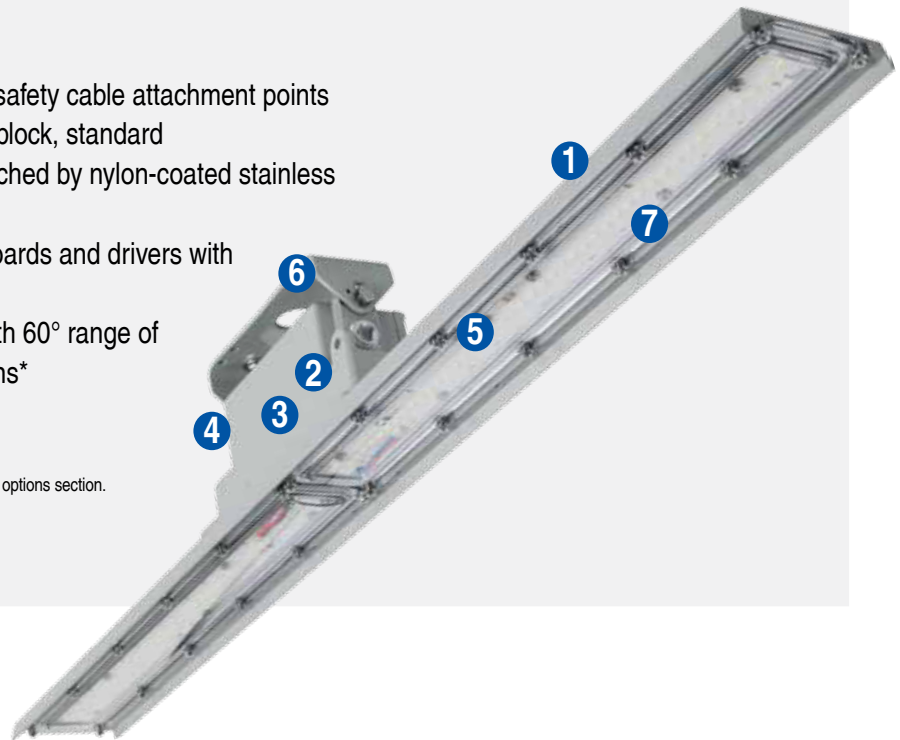

Additional Features:

- Central safety cable attachment points for increased safety/reduced range of motion
- Feed-through capable
- Optional end brackets for chain mount applications
- Emergency battery back-up
- Diffused lens option
- 10 kV standard surge protection
- 5-year warranty

Standard Materials:

- Body: 6061T5 aluminum (less than .4% copper content) with baked-on gray epoxy finish
- Driver body: A360 aluminum (less than .4% copper content) with baked-on gray epoxy finish
- Gaskets: one-piece neoprene
- Optional end brackets: stainless steel
- Lens: polycarbonate
- Hardware: stainless steel



LED ML

Linear LED Lighting for Harsh Environments

Catalog Number Logic

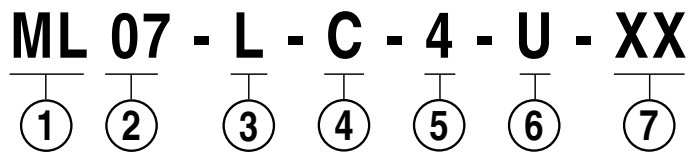

1 BASIC LUMINAIRE
ML = Harsh Environment Linear LED¹
CEML = CE LED

2 LAMP WATTAGE
07 = 80 Watt (4 foot)
04 = 40 Watt (2 foot)

3 LAMP TYPE
L = LED (4000K CCT)

4 LENS
C = Clear
D = Diffused

5 NOMINAL FIXTURE LENGTH
2 = 2 Foot
4 = 4 Foot

6 VOLTAGE/ FREQUENCY
U = 120 - 277V 50/60HZ
N = 347/480V 60HZ
A = 120V 60HZ²
B = 220 - 240V 50/60HZ²
C = 277V 60HZ²

7 OPTIONS
RIG = Mounting Bracket & (2) Safety Cables
MB = Mounting Bracket Ceiling or Wall
EB = End Brackets Cable or Chain Suspension
HA = High Ambient 65°C Rated (4 ft. Model Only)
EM = Emergency Battery Backup
SP = Increased Surge Protection, 10kV (Not available with 347/480V)
FB = Fuse Block (Not Available with 347/480V)²
SC = Safety Cable
30 = 3000K CCT
35 = 3500K CCT
50 = 5000K CCT

¹Mounting Hardware not included. Please see options for mounting selections.

²Specify voltage when option FB is needed. When option FB is selected, one fuse is provided for 120 and 277V. Two fuses are provided for 220-240V. Fuse option not available for marine listed fixtures, or for fixtures listed for use in Canada.



Project
MGD EXPANSION

Catalog Number
ML07-L-C-4-U-MBEM

Type
L1E

Notes

LED
ML

Linear LED Lighting for Harsh Environments

Certification Guide

Model	Length	Wattage	Operating Voltage	Total Lumens	Lumen per Watt	CRI	CCT	Ambient Temperature	Supply Wire Suitable Temperature, °C
ML04LC2	2 ft	40W	120V - 277V 50/60 Hz,	4068	101	84	4009	-40°C < Tamb < 55°C	90°C
ML07LC4	4 ft	80W	347V/480V 60Hz	7654	102	84	4105	-35°C < Tamb < 60°C	90°C
ML04LD2	2 ft	40W	120V - 277V 50/60 Hz,	3737	93	83	3916	-40°C < Tamb < 55°C	90°C
ML07LD4	4 ft	80W	347V/480V 60Hz	7453	99	83	4034	-35°C < Tamb < 60°C	90°C
ML07LC4-HA	4 ft	80W	120V - 277V 50/60 Hz,	7654	102	84	4105	-30°C < Tamb < 65°C	90°C
ML07LD4-HA	4 ft	80W	347V/480V 60Hz	7453	99	83	4034	-30°C < Tamb < 65°C	90°C

ML07LC4U

Coefficients of Utilization

% Effective Ceiling Cavity Reflectance rcc	80				70				50				30				10				0
	70	50	30	10	70	50	30	10	50	30	10	50	30	10	50	30	10	50	30	10	0
Room Cavity Ratio RCR	Effective Floor Cavity Reflectance 20%																				
0	119	119	119	119	116	116	116	116	111	111	111	111	106	106	106	102	102	102	102	100	
1	110	105	101	98	107	103	99	96	99	96	93	95	92	90	91	89	88	85	85	85	
2	100	92	86	80	98	90	84	79	87	82	78	84	79	76	81	77	74	72	74	72	
3	91	81	74	67	89	80	73	67	77	71	65	74	69	64	72	67	63	61	63	61	
4	84	72	64	57	82	71	63	57	68	61	56	66	60	55	64	59	54	52	54	52	
5	77	65	56	49	75	63	55	49	61	54	48	59	53	48	58	52	47	45	47	45	
6	71	58	49	43	69	57	49	43	55	48	42	54	47	42	52	46	42	40	42	40	
7	66	53	44	38	64	52	44	38	50	43	38	49	42	37	48	42	37	35	37	35	
8	61	48	40	34	60	47	39	34	46	39	34	45	38	33	44	38	33	31	33	31	
9	57	44	36	31	56	44	36	30	42	35	30	41	35	30	40	34	30	28	30	28	
10	54	41	33	28	53	40	33	28	39	32	27	38	32	27	37	31	27	25	27	25	

Candlepower Distribution

Deg.	0	15	30	45	60	75	90
0	2823	2823	2823	2823	2823	2823	2823
15	2729	2710	2712	2720	2722	2718	2719
25	2514	2529	2533	2537	2537	2514	2540
35	2259	2262	2262	2270	2270	2275	2282
45	1868	1879	1888	1910	1930	1915	1923
55	1400	1405	1418	1444	1460	1444	1449
65	748	737	821	901	934	965	972
75	117	164	450	367	337	381	403
85	29	29	30	32	35	45	56
95	0	0	0	0	0	30	35
105	0	0	0	0	0	0	0

Photometric Data

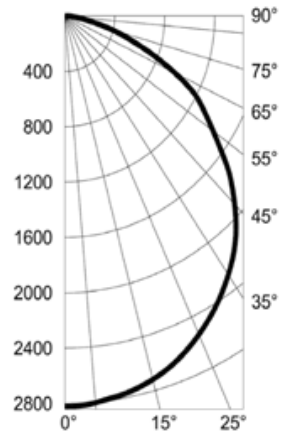

ML04LC2U

Coefficients of Utilization

% Effective Ceiling Cavity Reflectance rcc	80				70				50				30				10				0
	70	50	30	10	70	50	30	10	50	30	10	50	30	10	50	30	10	50	30	10	0
Room Cavity Ratio RCR	Effective Floor Cavity Reflectance 20%																				
0	119	119	119	119	116	116	116	116	111	111	111	111	106	106	106	102	102	102	102	100	
1	109	104	100	96	106	102	98	94	98	94	91	94	91	89	90	88	86	84	84	84	
2	99	91	84	78	96	89	83	77	85	80	76	82	78	74	79	75	72	70	72	70	
3	90	80	72	65	88	78	71	65	75	69	64	73	67	62	70	65	61	59	61	59	
4	83	71	62	56	81	70	61	55	67	60	54	65	59	54	63	57	53	51	53	51	
5	76	63	55	48	74	62	54	48	60	53	47	58	52	47	56	51	46	44	46	44	
6	70	57	48	42	69	56	48	42	54	47	41	53	46	41	51	45	41	39	41	39	
7	65	52	43	37	64	51	43	37	50	42	37	48	41	36	47	41	36	34	36	34	
8	61	47	39	33	59	47	39	33	45	38	33	44	38	33	43	37	32	31	33	31	
9	57	44	35	30	56	43	35	30	42	35	30	41	34	30	40	34	29	28	30	28	
10	53	40	32	27	52	40	32	27	39	32	27	38	31	27	37	31	27	25	27	25	

Candlepower Distribution

Deg.	0	15	30	45	60	75	90
0	1445	1445	1445	1445	1445	1445	1445
15	1395	1396	1393	1401	1394	1397	1401
25	1308	1309	1305	1313	1308	1311	1311
35	1176	1173	1174	1180	1175	1174	1175
45	998	999	1006	998	995	996	998
55	749	759	773	781	774	771	771
65	505	510	502	501	489	495	499
75	221	215	211	222	198	177	133
85	34	34	13	11	9	8	8
95	13	10	9	8	7	7	7
105	12	0	0	0	0	0	0
115	11	0	0	0	0	0	0

Photometric Data

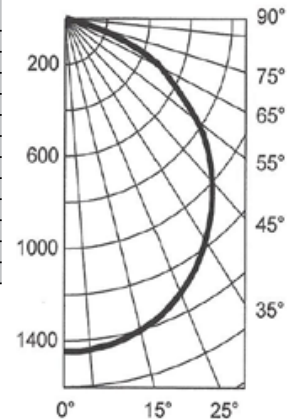



LED ML

Linear LED Lighting for Harsh Environments

ML07LD4U

Coefficients of Utilization

% Effective Ceiling Cavity Reflectance rcc	80				70				50				30				10				0
	70	50	30	10	70	50	30	10	70	50	30	10	70	50	30	10	70	50	30	10	0
% Wall Reflectance rw	70	50	30	10	70	50	30	10	70	50	30	10	70	50	30	10	70	50	30	10	0
Room Cavity Ratio RCR	Effective Floor Cavity Reflectance 20%																				
0	119	119	119	119	116	116	116	116	111	111	111	111	106	106	106	106	102	102	102	102	100
1	109	104	100	96	106	102	98	94	98	94	91	94	91	89	90	88	86	86	84	84	84
2	99	91	84	78	96	89	83	77	85	80	76	82	78	74	79	75	72	72	70	70	70
3	90	80	72	65	88	78	71	65	75	69	64	73	67	62	70	65	61	59	59	59	59
4	83	71	62	56	81	70	61	55	67	60	54	65	59	54	63	57	53	51	51	51	51
5	76	63	55	48	74	62	54	48	60	53	47	58	52	47	56	51	46	44	44	44	44
6	70	57	48	42	69	56	48	42	54	47	41	53	46	41	51	45	41	39	39	39	39
7	65	52	43	37	64	51	43	37	50	42	37	48	41	36	47	41	36	34	34	34	34
8	61	47	39	33	59	47	39	33	45	38	33	44	38	33	43	37	32	31	31	31	31
9	57	44	35	30	56	43	35	30	42	35	30	41	34	30	40	34	29	28	28	28	28
10	53	40	32	27	52	40	32	27	39	32	27	38	31	27	37	31	27	25	25	25	25

Candlepower Distribution

Deg.	0	15	30	45	60	75	90
0	2836	2836	2836	2836	2836	2836	2836
15	2687	2679	2682	2683	2679	2672	2671
25	2424	2427	2428	2430	2424	2415	2414
35	2098	2094	2093	2090	2084	2072	2070
45	1715	1713	1710	1700	1694	1679	1679
55	1317	1313	1309	1295	1280	1264	1260
65	928	925	920	909	889	868	859
75	498	502	501	494	478	455	440
85	77	80	88	96	98	103	93
95	0	0	0	0	0	26	27
105	0	0	0	0	0	0	0

Photometric Data

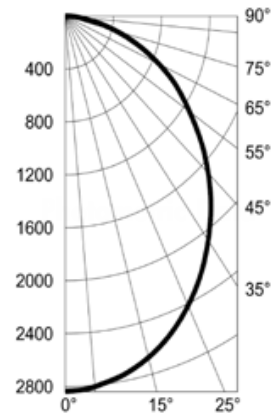

ML04LD2U

Coefficients of Utilization

% Effective Ceiling Cavity Reflectance rcc	80				70				50				30				10				0
	70	50	30	10	70	50	30	10	70	50	30	10	70	50	30	10	70	50	30	10	0
% Wall Reflectance rw	70	50	30	10	70	50	30	10	70	50	30	10	70	50	30	10	70	50	30	10	0
Room Cavity Ratio RCR	Effective Floor Cavity Reflectance 20%																				
0	119	119	119	119	116	116	116	116	111	111	111	111	106	106	106	106	102	102	102	102	100
1	109	104	99	96	106	101	98	94	97	94	91	93	91	88	90	87	85	83	83	83	83
2	99	90	84	78	96	89	82	77	85	80	75	82	77	73	78	75	72	69	69	69	69
3	90	79	71	65	88	78	70	64	75	68	63	72	66	62	69	65	61	58	58	58	58
4	82	70	62	55	80	69	61	54	67	59	54	64	58	53	62	57	52	50	50	50	50
5	76	63	54	48	74	62	53	47	60	52	46	58	51	46	56	50	45	43	43	43	43
6	70	57	48	41	68	56	47	41	54	46	41	52	45	40	51	45	40	38	38	38	38
7	65	51	43	37	63	51	42	36	49	42	36	48	41	36	46	40	36	34	34	34	34
8	61	47	39	33	59	46	38	33	45	38	32	44	37	32	42	36	32	30	30	30	30
9	57	43	35	29	55	43	35	29	41	34	29	40	34	29	39	33	29	27	27	27	27
10	53	40	32	27	52	39	32	27	38	31	27	37	31	26	36	31	26	24	24	24	24

Candlepower Distribution

Deg.	0	15	30	45	60	75	90
0	1373	1373	1373	1373	1373	1373	1373
15	1303	1304	1304	1311	1306	1309	1312
25	1183	1185	1187	1195	1192	1196	1198
35	1021	1021	1027	1035	1037	1041	1043
45	827	831	842	850	856	861	863
55	624	631	646	656	664	670	672
65	423	432	448	460	467	471	472
75	229	239	254	263	268	269	270
85	54	64	64	59	60	62	64
95	11	11	10	8	7	7	6
105	0	0	0	0	0	0	0

Photometric Data

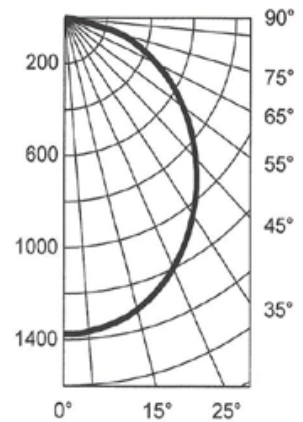



Project
MGD EXPANSION

Catalog Number
ML07-L-C-4-U-MBEM

Type
L1E

Notes

LED ML

Linear LED Lighting for Harsh Environments

Fixture Dimensions (inches)

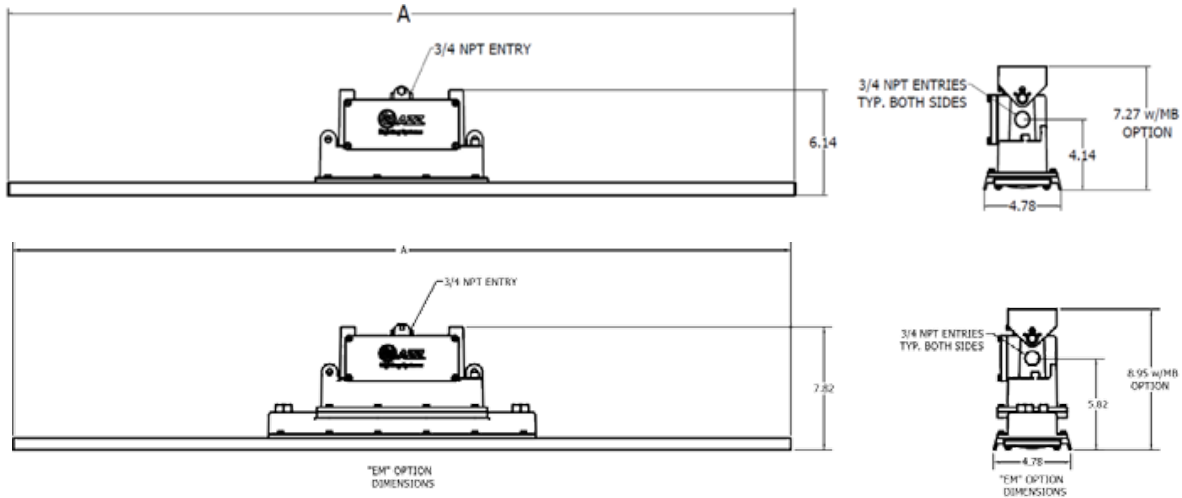

ML SERIES	Dimensions (inches)	Boxed Weight	Shipping Volume
	A		
4 ft. models	48.00	18 lbs.	1.47 cu. ft.
2 ft. models	24.00	10 lbs.	.76 cu. ft.

Accessories



ML LED

Linear LED Lighting for Harsh Environments

- UL 1598A Marine Outside Type
- UL 1598 Wet Location
- UL 8750 LED Safety
- UL 924 Emergency Lighting
- -40°C to 65°C Ambient Temperature
- CSA C22.2 No. 250.0-08
- NEMA 4X
- CE
- IP66
- Tested to LM 79 & LM 80



ML
LED



ML LED

Linear LED Lighting for Harsh Environments

Key Features:

- 1 Low-profile, lightweight design
- 2 Heavy-duty, 3/8" thick die-cast safety cable attachment points
- 3 Tool-less, cage-clamp terminal block, standard
- 4 Captive junction box cover, attached by nylon-coated stainless steel cable
- 5 Field replaceable LED circuit boards and drivers with quick disconnects
- 6 Adjustable mounting bracket with 60° range of motion and nine locking positions*
- 7 Impact resistant clear lens

* Not included, must be ordered separately. Please see options section.

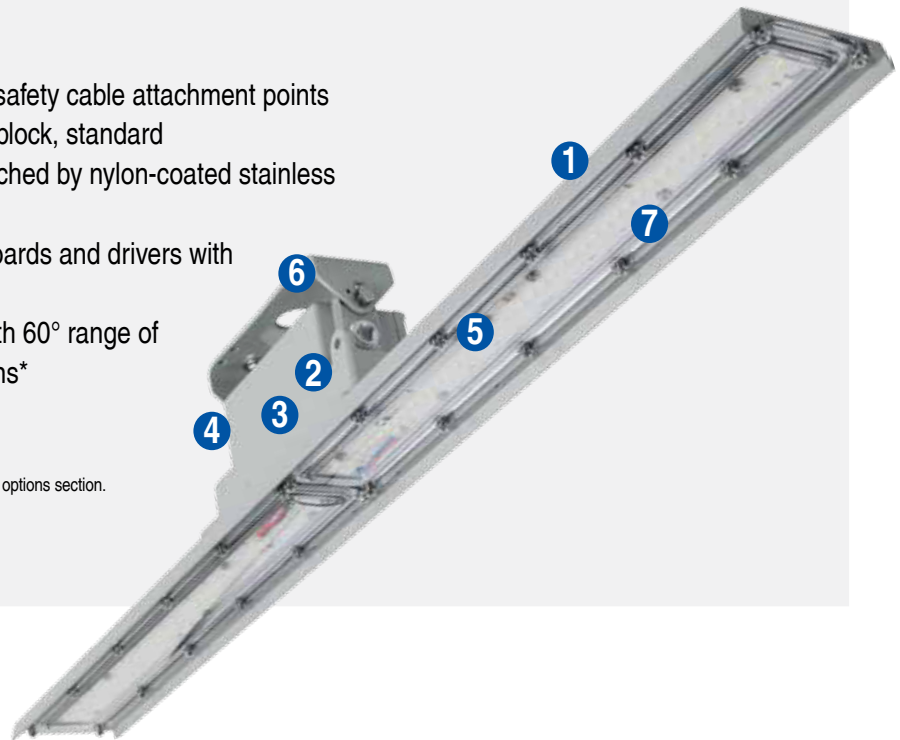

Additional Features:

- Central safety cable attachment points for increased safety/reduced range of motion
- Feed-through capable
- Optional end brackets for chain mount applications
- Emergency battery back-up
- Diffused lens option
- 10 kV standard surge protection
- 5-year warranty

Standard Materials:

- Body: 6061T5 aluminum (less than .4% copper content) with baked-on gray epoxy finish
- Driver body: A360 aluminum (less than .4% copper content) with baked-on gray epoxy finish
- Gaskets: one-piece neoprene
- Optional end brackets: stainless steel
- Lens: polycarbonate
- Hardware: stainless steel



LED ML

Linear LED Lighting for Harsh Environments

Catalog Number Logic

ML 07 - L - C - 4 - U - XX

① ② ③ ④ ⑤ ⑥ ⑦

1 BASIC LUMINAIRE
ML = Harsh Environment Linear LED¹
CEML = CE LED

2 LAMP WATTAGE
07 = 80 Watt (4 foot)
04 = 40 Watt (2 foot)

3 LAMP TYPE
L = LED (4000K CCT)

4 LENS
C = Clear
D = Diffused

5 NOMINAL FIXTURE LENGTH
2 = 2 Foot
4 = 4 Foot

6 VOLTAGE/ FREQUENCY
U = 120 - 277V 50/60HZ
N = 347/480V 60HZ
A = 120V 60HZ²
B = 220 - 240V 50/60HZ²
C = 277V 60HZ²

7 OPTIONS
RIG = Mounting Bracket & (2) Safety Cables
MB = Mounting Bracket Ceiling or Wall
EB = End Brackets Cable or Chain Suspension
HA = High Ambient 65°C Rated (4 ft. Model Only)
EM = Emergency Battery Backup
SP = Increased Surge Protection, 10kV (Not available with 347/480V)
FB = Fuse Block (Not Available with 347/480V)²
SC = Safety Cable
30 = 3000K CCT
35 = 3500K CCT
50 = 5000K CCT

¹Mounting Hardware not included. Please see options for mounting selections.

²Specify voltage when option FB is needed. When option FB is selected, one fuse is provided for 120 and 277V. Two fuses are provided for 220-240V. Fuse option not available for marine listed fixtures, or for fixtures listed for use in Canada.



Project
MGD EXPANSION

Catalog Number
ML04-L-C-2-U-MB

Type
L2

Notes

LED
ML

Linear LED Lighting for Harsh Environments

Certification Guide

Model	Length	Wattage	Operating Voltage	Total Lumens	Lumen per Watt	CRI	CCT	Ambient Temperature	Supply Wire Suitable Temperature, °C
ML04LC2	2 ft	40W	120V - 277V 50/60 Hz,	4068	101	84	4009	-40°C < Tamb < 55°C	90°C
ML07LC4	4 ft	80W	347V/480V 60Hz	7654	102	84	4105	-35°C < Tamb < 60°C	90°C
ML04LD2	2 ft	40W	120V - 277V 50/60 Hz,	3737	93	83	3916	-40°C < Tamb < 55°C	90°C
ML07LD4	4 ft	80W	347V/480V 60Hz	7453	99	83	4034	-35°C < Tamb < 60°C	90°C
ML07LC4-HA	4 ft	80W	120V - 277V 50/60 Hz,	7654	102	84	4105	-30°C < Tamb < 65°C	90°C
ML07LD4-HA	4 ft	80W	347V/480V 60Hz	7453	99	83	4034	-30°C < Tamb < 65°C	90°C

ML07LC4U

Coefficients of Utilization

Room Cavity Ratio RCR	% Effective Ceiling Cavity Reflectance rcc				80				70				50				30				10				0			
	70	50	30	10	70	50	30	10	70	50	30	10	70	50	30	10	70	50	30	10	70	50	30	10	70	50	30	10
0	119	119	119	119	116	116	116	116	111	111	111	111	106	106	106	106	102	102	102	102	102	102	102	102	100	100	100	100
1	110	105	101	98	107	103	99	96	99	96	93	95	92	90	91	89	88	85	85	85	85	85	85	85	85	85	85	85
2	100	92	86	80	98	90	84	79	87	82	78	84	79	76	81	77	74	72	74	72	72	72	72	72	72	72	72	72
3	91	81	74	67	89	80	73	67	77	71	65	74	69	64	72	67	63	61	63	61	61	61	61	61	61	61	61	61
4	84	72	64	57	82	71	63	57	68	61	56	66	60	55	64	59	54	52	54	52	52	52	52	52	52	52	52	52
5	77	65	56	49	75	63	55	49	61	54	48	59	53	48	58	52	47	45	47	45	45	45	45	45	45	45	45	45
6	71	58	49	43	69	57	49	43	55	48	42	54	47	42	52	46	42	40	42	40	40	40	40	40	40	40	40	40
7	66	53	44	38	64	52	44	38	50	43	38	49	42	37	48	42	37	35	37	35	35	35	35	35	35	35	35	35
8	61	48	40	34	60	47	39	34	46	39	34	45	38	33	44	38	33	31	33	31	31	31	31	31	31	31	31	31
9	57	44	36	31	56	44	36	30	42	35	30	41	35	30	40	34	30	28	30	28	28	28	28	28	28	28	28	28
10	54	41	33	28	53	40	33	28	39	32	27	38	32	27	37	31	27	25	27	25	25	25	25	25	25	25	25	25

Candlepower Distribution

Deg.	0	15	30	45	60	75	90
0	2823	2823	2823	2823	2823	2823	2823
15	2729	2710	2712	2720	2722	2718	2719
25	2514	2529	2533	2537	2537	2514	2540
35	2259	2262	2262	2270	2270	2275	2282
45	1868	1879	1888	1910	1930	1915	1923
55	1400	1405	1418	1444	1460	1444	1449
65	748	737	821	901	934	965	972
75	117	164	450	367	337	381	403
85	29	29	30	32	35	45	56
95	0	0	0	0	0	30	35
105	0	0	0	0	0	0	0

Photometric Data

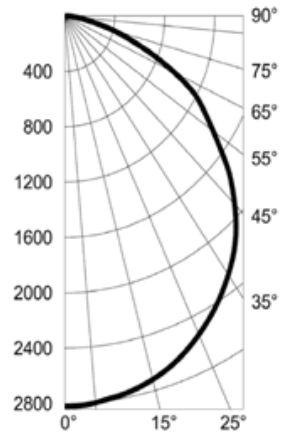

ML04LC2U

Coefficients of Utilization

Room Cavity Ratio RCR	% Effective Ceiling Cavity Reflectance rcc				80				70				50				30				10				0			
	70	50	30	10	70	50	30	10	70	50	30	10	70	50	30	10	70	50	30	10	70	50	30	10	70	50	30	10
0	119	119	119	119	116	116	116	116	111	111	111	111	106	106	106	106	102	102	102	102	102	102	102	102	100	100	100	100
1	109	104	100	96	106	102	98	94	98	94	91	94	91	89	90	88	86	84	86	84	84	84	84	84	84	84	84	84
2	99	91	84	78	96	89	83	77	85	80	76	82	74	79	75	72	70	72	70	72	70	70	70	70	70	70	70	70
3	90	80	72	65	88	78	71	65	75	69	64	73	67	62	70	65	61	59	61	59	59	59	59	59	59	59	59	59
4	83	71	62	56	81	70	61	55	67	60	54	65	59	54	63	57	53	51	53	51	51	51	51	51	51	51	51	51
5	76	63	55	48	74	62	54	48	60	53	47	58	52	47	56	51	46	44	46	44	44	44	44	44	44	44	44	44
6	70	57	48	42	69	56	48	42	54	47	41	53	46	41	51	45	41	39	41	39	39	39	39	39	39	39	39	39
7	65	52	43	37	64	51	43	37	50	42	37	48	41	36	47	41	36	34	36	34	34	34	34	34	34	34	34	34
8	61	47	39	33	59	47	39	33	45	38	33	44	38	33	43	37	32	31	32	31	31	31	31	31	31	31	31	31
9	57	44	35	30	56	43	35	30	42	35	30	41	34	30	40	34	29	28	29	28	28	28	28	28	28	28	28	28
10	53	40	32	27	52	40	32	27	39	32	27	38	31	27	37	31	27	25	27	25	25	25	25	25	25	25	25	25

Candlepower Distribution

Deg.	0	15	30	45	60	75	90
0	1445	1445	1445	1445	1445	1445	1445
15	1395	1396	1393	1401	1394	1397	1401
25	1308	1309	1305	1313	1308	1311	1311
35	1176	1173	1174	1180	1175	1174	1175
45	998	999	1006	998	995	996	998
55	749	759	773	781	774	771	771
65	505	510	502	501	489	495	499
75	221	215	211	222	198	177	133
85	34	34	13	11	9	8	8
95	13	10	9	8	7	7	7
105	12	0	0	0	0	0	0
115	11	0	0	0	0	0	0

Photometric Data

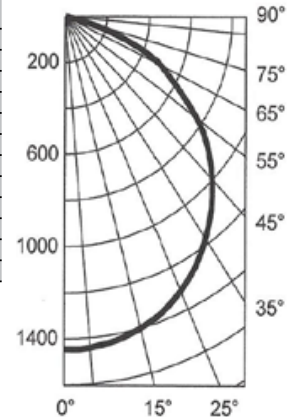



LED ML

Linear LED Lighting for Harsh Environments

ML07LD4U

Coefficients of Utilization

% Effective Ceiling Cavity Reflectance rcc	80				70				50				30				10				0
	70	50	30	10	70	50	30	10	70	50	30	10	70	50	30	10	70	50	30	10	0
Room Cavity Ratio RCR	Effective Floor Cavity Reflectance 20%																				
0	119	119	119	119	116	116	116	116	111	111	111	111	106	106	106	106	102	102	102	102	100
1	109	104	100	96	106	102	98	94	98	94	91	94	91	89	90	88	86	86	84	84	84
2	99	91	84	78	96	89	83	77	85	80	76	82	78	74	79	75	72	72	70	70	70
3	90	80	72	65	88	78	71	65	75	69	64	73	67	62	70	65	61	59	59	59	59
4	83	71	62	56	81	70	61	55	67	60	54	65	59	54	63	57	53	51	51	51	51
5	76	63	55	48	74	62	54	48	60	53	47	58	52	47	56	51	46	44	44	44	44
6	70	57	48	42	69	56	48	42	54	47	41	53	46	41	51	45	41	39	39	39	39
7	65	52	43	37	64	51	43	37	50	42	37	48	41	36	47	41	36	34	34	34	34
8	61	47	39	33	59	47	39	33	45	38	33	44	38	33	43	37	32	31	31	31	31
9	57	44	35	30	56	43	35	30	42	35	30	41	34	30	40	34	29	28	28	28	28
10	53	40	32	27	52	40	32	27	39	32	27	38	31	27	37	31	27	25	25	25	25

Candlepower Distribution

Deg.	0	15	30	45	60	75	90
0	2836	2836	2836	2836	2836	2836	2836
15	2687	2679	2682	2683	2679	2672	2671
25	2424	2427	2428	2430	2424	2415	2414
35	2098	2094	2093	2090	2084	2072	2070
45	1715	1713	1710	1700	1694	1679	1679
55	1317	1313	1309	1295	1280	1264	1260
65	928	925	920	909	889	868	859
75	498	502	501	494	478	455	440
85	77	80	88	96	98	103	93
95	0	0	0	0	0	26	27
105	0	0	0	0	0	0	0

Photometric Data

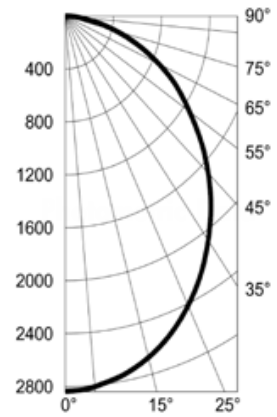

ML04LD2U

Coefficients of Utilization

% Effective Ceiling Cavity Reflectance rcc	80				70				50				30				10				0
	70	50	30	10	70	50	30	10	70	50	30	10	70	50	30	10	70	50	30	10	0
Room Cavity Ratio RCR	Effective Floor Cavity Reflectance 20%																				
0	119	119	119	119	116	116	116	116	111	111	111	111	106	106	106	106	102	102	102	102	100
1	109	104	99	96	106	101	98	94	97	94	91	93	91	88	90	87	85	83	83	83	83
2	99	90	84	78	96	89	82	77	85	80	75	82	77	73	78	75	72	69	69	69	69
3	90	79	71	65	88	78	70	64	75	68	63	72	66	62	69	65	61	58	58	58	58
4	82	70	62	55	80	69	61	54	67	59	54	64	58	53	62	57	52	50	50	50	50
5	76	63	54	48	74	62	53	47	60	52	46	58	51	46	56	50	45	43	43	43	43
6	70	57	48	41	68	56	47	41	54	46	41	52	45	40	51	45	40	38	38	38	38
7	65	51	43	37	63	51	42	36	49	42	36	48	41	36	46	40	36	34	34	34	34
8	61	47	39	33	59	46	38	33	45	38	32	44	37	32	42	36	32	30	30	30	30
9	57	43	35	29	55	43	35	29	41	34	29	40	34	29	39	33	29	27	27	27	27
10	53	40	32	27	52	39	32	27	38	31	27	37	31	26	36	31	26	24	24	24	24

Candlepower Distribution

Deg.	0	15	30	45	60	75	90
0	1373	1373	1373	1373	1373	1373	1373
15	1303	1304	1304	1311	1306	1309	1312
25	1183	1185	1187	1195	1192	1196	1198
35	1027	1021	1027	1035	1037	1041	1043
45	827	831	842	850	856	861	863
55	624	631	646	656	664	670	672
65	423	432	448	460	467	471	472
75	229	239	254	263	268	269	270
85	54	64	64	59	60	62	64
95	11	11	10	8	7	7	6
105	0	0	0	0	0	0	0

Photometric Data

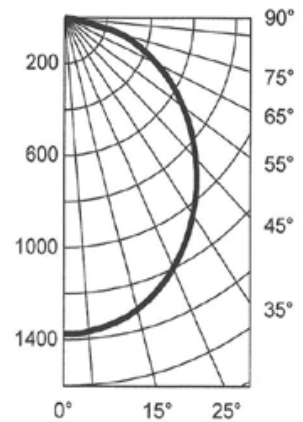



Project
MGD EXPANSION

Catalog Number
ML04-L-C-2-U-MB

Type
L2

Notes

LED ML

Linear LED Lighting for Harsh Environments

Fixture Dimensions (inches)

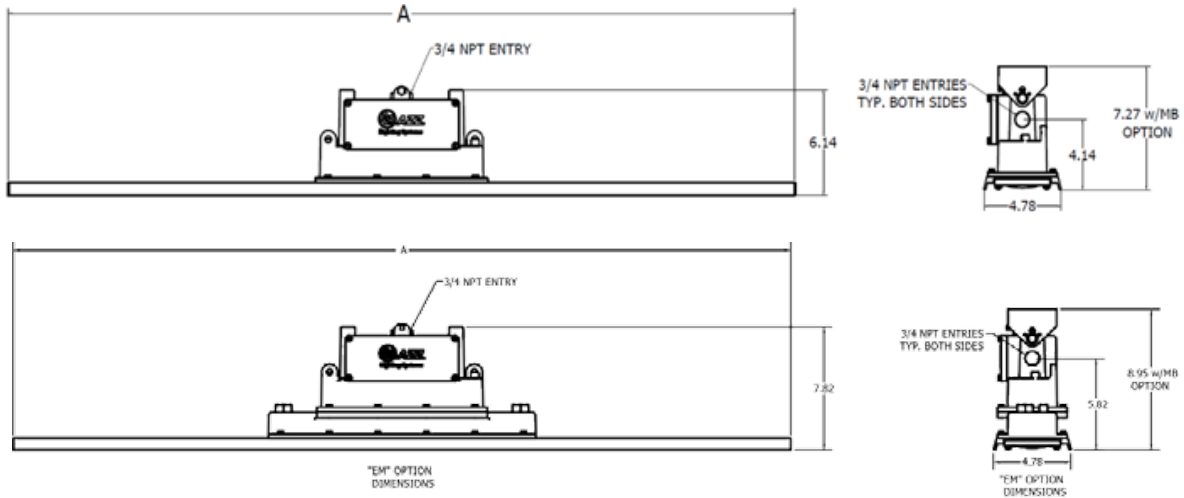

ML SERIES	Dimensions (inches)	Boxed Weight	Shipping Volume
	A		
4 ft. models	48.00	18 lbs.	1.47 cu. ft.
2 ft. models	24.00	10 lbs.	.76 cu. ft.

Accessories



Mounting Bracket

Ceiling or Wall
Catalog Number: 53050
Shipping Weight: 2 lbs.



End Brackets

Cables or Chain
Catalog Number: 53051
Shipping Weight: 1 lbs.



Beam Clamp

Catalog Number: 38083
Shipping Weight: 1.25 lbs.



Beam Clamp Mounting Kit

Catalog Number: 53010
Shipping Weight: 3 lbs.



Safety Cable

Catalog Number: 10128R
Shipping Weight: 1 lb.

MHL LED

Linear LED Lighting for Hazardous Locations

- Class I, Division 2, Groups A, B, C & D
- Class II, Division 2, Groups F & G
- Class III
- UL 1598A Marine Outside Type
- UL 1598 Wet Locations
- UL 8750 LED Safety
- UL 844 Hazardous Locations
- UL 924 Emergency Lighting
- -40°C to 65°C Ambient Temperature
- CSA C22.2 No. 250.0-08
- CSA C22.2 No. 137-M1981
- NEMA 4X
- IP66
- ETL Listed
- Tested to LM 79 & LM 80



MHL
LED

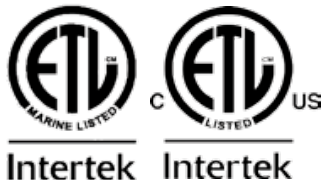

MHL LED

Linear LED Lighting for Hazardous Locations

Key Features:

- 1 Low-profile, lightweight design
- 2 Heavy-duty, 3/8" thick die-cast safety cable attachment points
- 3 Toolless, cage-clamp terminal block
- 4 Captive junction box cover, attached by nylon-coated stainless steel cable
- 5 Field replaceable LED circuit boards and drivers with quick disconnects
- 6 Adjustable mounting bracket with 60° range of motion and nine locking positions*
- 7 Impact resistant clear lens

* Not included, must be ordered separately. Please see options section.

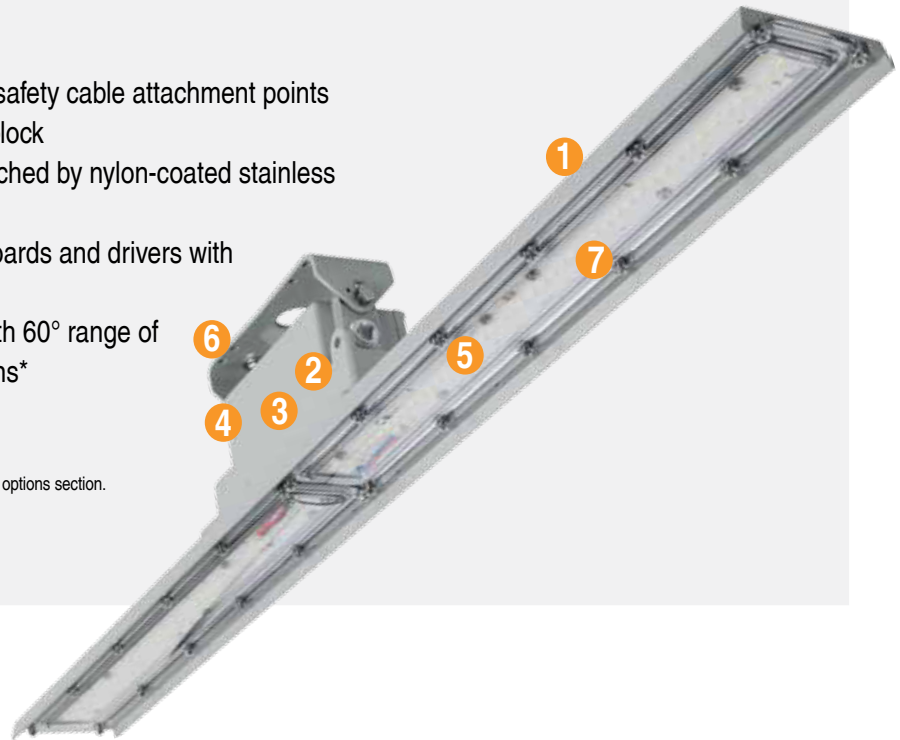

Additional Features:

- Central safety cable attachment points for increased safety/reduced range of motion
- Feed-through capable
- Optional end brackets for chain mount applications
- Emergency battery back-up
- Diffused lens option
- 4kV surge protection (10kV option available)
- 5-year warranty

Standard Materials:

- Body: 6061T5 aluminum (less than .4% copper content) with baked-on gray epoxy finish
- Driver body: A360 aluminum (less than .4% copper content) with baked-on gray epoxy finish
- Gaskets: one-piece neoprene
- Optional end brackets: stainless steel
- Lens: polycarbonate
- Hardware: stainless steel



LED MHL LED

Linear LED Lighting for Hazardous Locations

Catalog Number Logic

MHL 07 - L - C - 4 - U - XX

① ② ③ ④ ⑤ ⑥ ⑦

① BASIC SERIES
MHL Series¹
Hazardous Locations
Class I, Division 2, Groups A, B, C & D
Class II, Division 2, Groups F & G
Class III
UL 1598A Marine Outside Type
UL 844
UL 928
UL 8750 LED
CSA C22.2
NEMA 4X
IP66
ETL Listed

② LAMP WATTAGE
07 = 80 Watt (4 foot)
04 = 40 Watt (2 foot)

③ LAMP TYPE
L = LED (4000K CCT)

④ LENS
C = Clear
D = Diffused

⑤ NOMINAL FIXTURE LENGTH
2 = 2 Foot
4 = 4 Foot

⑥ VOLTAGE/ FREQUENCY
U = 120 - 277V 50/60HZ
N = 347/480V 60HZ
A = 120V 60HZ²
B = 220 - 240V 50/60HZ²
C = 277V 60HZ²

⑦ OPTIONS
RIG = Mounting Bracket & (2) Safety Cables
MB = Mounting Bracket Ceiling or Wall
EB = End Brackets Cable or Chain Suspension
HA = High Ambient 65°C Rated (4 ft. Model Only)
EM = Emergency Battery Backup
SP = Increased Surge Protection, 10kV (Not available with 347/480V)
FB = Fuse Block (Not Available with 347/480V)²
30 = 3000K CCT
35 = 3500K CCT
50 = 5000K CCT

¹Mounting Hardware not included. Please see options for mounting selections.
²Specify voltage when option FB is needed. When option FB is selected, one fuse is provided for 120 and 277V. Two fuses are provided for 220-240V. Fuse option not available for marine listed fixtures, or for fixtures listed for use in Canada.



LED MHL LED

Linear LED Lighting for Hazardous Locations

Certification Guide

Model	Length	Wattage	Operating Voltage	Total Lumens	Lumen per Watt	CRI	CCT	Comparable Fluorescent Luminaire	Ambient Temperature	Class I, Div. 2, Group A, B, C & D	Class II, Div. 2, Group F & G Class III	Simultaneous Presence	Supply Wire Suitable Temperature, °C
MHL04LC2	2 ft	40W	120V - 277V 50/60 Hz,	4068	101	84	4009	2 X 24W T5H0 / 2 X 35W T12H0	-40°C < Tamb < 55°C	T4A	T4A	T4A	90°C
MHL07LC4	4 ft	80W	347V/480V 60Hz	7654	102	84	4105	2 X 54W T5H0 / 2 X 60W T12H0	-35°C < Tamb < 60°C	T4A	T4A	T4A	90°C
MHL04LD2	2 ft	40W	120V - 277V 50/60 Hz,	3737	93	83	3916	2 X 24W T5H0 / 2 X 35W T12H0	-40°C < Tamb < 55°C	T4A	T4A	T4A	90°C
MHL07LD4	4 ft	80W	347V/480V 60Hz	7453	99	83	4034	2 X 54W T5H0 / 2 X 60W T12H0	-35°C < Tamb < 60°C	T4A	T4A	T4A	90°C
MHL07LC4-HA	4 ft	40W	120V - 277V 50/60 Hz,	7654	102	84	4105	2 X 54W T5H0 / 2 X 60W T12H0	-30°C < Tamb < 65°C	T4A	T4A	T4A	90°C
MHL07LD4-HA	4 ft	80W	347V/480V 60Hz	7453	99	83	4034	2 X 54W T5H0 / 2 X 60W T12H0	-30°C < Tamb < 65°C	T4A	T4A	T4A	90°C

MHL07LC4U

Coefficients of Utilization

% Effective Ceiling Cavity Reflectance rcc	80				70				50				30				10				0
	70	50	30	10	70	50	30	10	50	30	10	50	30	10	50	30	10	50	30	10	0
% Wall Reflectance rw	70	50	30	10	70	50	30	10	50	30	10	50	30	10	50	30	10	50	30	10	0
Room Cavity Ratio RCR	Effective Floor Cavity Reflectance 20%																				
0	119	119	119	119	116	116	116	116	111	111	111	106	106	106	102	102	102	102	102	100	
1	110	105	101	98	107	103	99	96	99	96	93	95	92	90	91	89	88	88	88	85	
2	100	92	86	80	98	90	84	79	87	82	78	84	79	76	81	77	74	74	72	72	
3	91	81	74	67	89	80	73	67	77	71	65	74	69	64	72	67	63	61	61	61	
4	84	72	64	57	82	71	63	57	68	61	56	66	60	55	64	59	54	52	52	52	
5	77	65	56	49	75	63	55	49	61	54	48	59	53	48	58	52	47	45	45	45	
6	71	58	49	43	69	57	49	43	55	48	42	54	47	42	52	46	42	40	40	40	
7	66	53	44	38	64	52	44	38	50	43	38	49	42	37	48	42	37	35	35	35	
8	61	48	40	34	60	47	39	34	46	39	34	45	38	33	44	38	33	31	31	31	
9	57	44	36	31	56	44	36	30	42	35	30	41	35	30	40	34	30	28	28	28	
10	54	41	33	28	53	40	33	28	39	32	27	38	32	27	37	31	27	25	25	25	

Candlepower Distribution

Deg.	0	15	30	45	60	75	90
0	2823	2823	2823	2823	2823	2823	2823
15	2729	2710	2712	2720	2722	2718	2719
25	2514	2529	2533	2537	2537	2514	2540
35	2259	2262	2262	2270	2270	2275	2282
45	1868	1879	1888	1910	1930	1915	1923
55	1400	1405	1418	1444	1460	1444	1449
65	748	737	821	901	934	965	972
75	117	164	450	367	337	381	403
85	29	29	30	32	35	45	56
95	0	0	0	0	0	30	35
105	0	0	0	0	0	0	0

Photometric Data

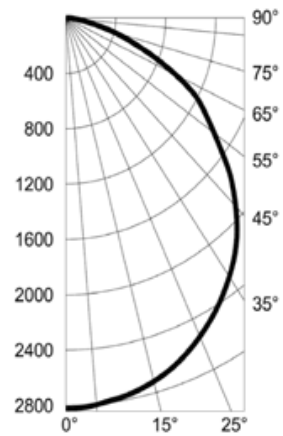

MHL04LC2U

Coefficients of Utilization

% Effective Ceiling Cavity Reflectance rcc	80				70				50				30				10				0
	70	50	30	10	70	50	30	10	50	30	10	50	30	10	50	30	10	50	30	10	0
% Wall Reflectance rw	70	50	30	10	70	50	30	10	50	30	10	50	30	10	50	30	10	50	30	10	0
Room Cavity Ratio RCR	Effective Floor Cavity Reflectance 20%																				
0	119	119	119	119	116	116	116	116	111	111	111	106	106	106	102	102	102	102	102	100	
1	109	104	100	96	106	102	98	94	98	94	91	94	91	89	90	88	86	86	84	84	
2	99	91	84	78	96	89	83	77	85	80	76	82	78	74	79	75	72	70	70	70	
3	90	80	72	65	88	78	71	65	75	69	64	73	67	62	70	65	61	59	59	59	
4	83	71	62	56	81	70	61	55	67	60	54	65	59	54	63	57	53	51	51	51	
5	76	63	55	48	74	62	54	48	60	53	47	58	52	47	56	51	46	44	44	44	
6	70	57	48	42	69	56	48	42	54	47	41	53	46	41	51	45	41	39	39	39	
7	65	52	43	37	64	51	43	37	50	42	37	48	41	36	47	41	36	34	34	34	
8	61	47	39	33	59	47	39	33	45	38	33	44	38	33	43	37	32	31	31	31	
9	57	44	35	30	56	43	35	30	42	35	30	41	34	30	40	34	29	28	28	28	
10	53	40	32	27	52	40	32	27	39	32	27	38	31	27	37	31	27	25	25	25	

Candlepower Distribution

Deg.	0	15	30	45	60	75	90
0	1445	1445	1445	1445	1445	1445	1445
15	1395	1396	1393	1401	1394	1397	1401
25	1308	1309	1305	1313	1308	1311	1311
35	1176	1173	1174	1180	1175	1174	1175
45	998	999	1006	998	995	996	998
55	749	759	773	781	774	771	771
65	505	510	502	501	489	495	499
75	221	215	211	222	198	177	133
85	34	34	13	11	9	8	8
95	13	10	9	8	7	7	7
105	12	0	0	0	0	0	0
115	11	0	0	0	0	0	0

Photometric Data

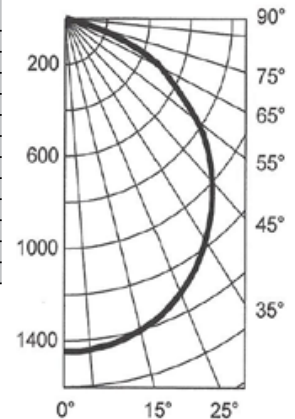



LED MHL LED

Linear LED Lighting for Hazardous Locations

MHL07LD4U

Coefficients of Utilization

% Effective Ceiling Cavity Reflectance rcc	80				70				50				30				10				0
	70	50	30	10	70	50	30	10	70	50	30	10	70	50	30	10	70	50	30	10	0
Room Cavity Ratio RCR	Effective Floor Cavity Reflectance 20%																				
0	119	119	119	119	116	116	116	116	111	111	111	111	106	106	106	106	102	102	102	102	100
1	109	104	100	96	106	102	98	94	98	94	91	94	91	89	90	88	86	86	84	84	84
2	99	91	84	78	96	89	83	77	85	80	76	82	78	74	79	75	72	72	70	70	70
3	90	80	72	65	88	78	71	65	75	69	64	73	67	62	70	65	61	59	59	59	59
4	83	71	62	56	81	70	61	55	67	60	54	65	59	54	63	57	53	51	51	51	51
5	76	63	55	48	74	62	54	48	60	53	47	58	52	47	56	51	46	44	44	44	44
6	70	57	48	42	69	56	48	42	54	47	41	53	46	41	51	45	41	39	39	39	39
7	65	52	43	37	64	51	43	37	50	42	37	48	41	36	47	41	36	34	34	34	34
8	61	47	39	33	59	47	39	33	45	38	33	44	38	33	43	37	32	31	31	31	31
9	57	44	35	30	56	43	35	30	42	35	30	41	34	30	40	34	29	28	28	28	28
10	53	40	32	27	52	40	32	27	39	32	27	38	31	27	37	31	27	25	25	25	25

Candlepower Distribution

Deg.	0	15	30	45	60	75	90
0	2836	2836	2836	2836	2836	2836	2836
15	2687	2679	2682	2683	2679	2672	2671
25	2424	2427	2428	2430	2424	2415	2414
35	2098	2094	2093	2090	2084	2072	2070
45	1715	1713	1710	1700	1694	1679	1679
55	1317	1313	1309	1295	1280	1264	1260
65	928	925	920	909	889	868	859
75	498	502	501	494	478	455	440
85	77	80	88	96	98	103	93
95	0	0	0	0	0	26	27
105	0	0	0	0	0	0	0

Photometric Data

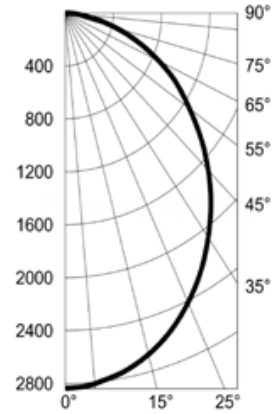

MHL04LD2U

Coefficients of Utilization

% Effective Ceiling Cavity Reflectance rcc	80				70				50				30				10				0
	70	50	30	10	70	50	30	10	70	50	30	10	70	50	30	10	70	50	30	10	0
Room Cavity Ratio RCR	Effective Floor Cavity Reflectance 20%																				
0	119	119	119	119	116	116	116	116	111	111	111	111	106	106	106	106	102	102	102	102	100
1	109	104	99	96	106	101	98	94	97	94	91	93	91	88	90	87	85	83	83	83	83
2	99	90	84	78	96	89	82	77	85	80	75	82	77	73	78	75	72	69	69	69	69
3	90	79	71	65	88	78	70	64	75	68	63	72	66	62	69	65	61	58	58	58	58
4	82	70	62	55	80	69	61	54	67	59	54	64	58	53	62	57	52	50	50	50	50
5	76	63	54	48	74	62	53	47	60	52	46	58	51	46	56	50	45	43	43	43	43
6	70	57	48	41	68	56	47	41	54	46	41	52	45	40	51	45	40	38	38	38	38
7	65	51	43	37	63	51	42	36	49	42	36	48	41	36	46	40	36	34	34	34	34
8	61	47	39	33	59	46	38	33	45	38	32	44	37	32	42	36	32	30	30	30	30
9	57	43	35	29	55	43	35	29	41	34	29	40	34	29	39	33	29	27	27	27	27
10	53	40	32	27	52	39	32	27	38	31	27	37	31	26	36	31	26	24	24	24	24

Candlepower Distribution

Deg.	0	15	30	45	60	75	90
0	1373	1373	1373	1373	1373	1373	1373
15	1303	1304	1304	1311	1306	1309	1312
25	1183	1185	1187	1195	1192	1196	1198
35	1021	1021	1027	1035	1037	1041	1043
45	827	831	842	850	856	861	863
55	624	631	646	656	664	670	672
65	423	432	448	460	467	471	472
75	229	239	254	263	268	269	270
85	54	64	64	59	60	62	64
95	11	11	10	8	7	7	6
105	0	0	0	0	0	0	0

Photometric Data

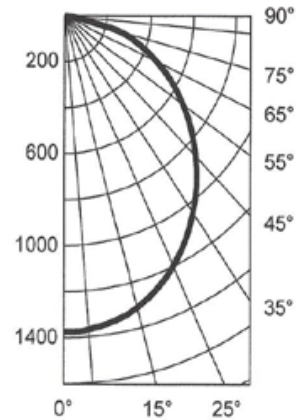



Project
MGD EXPANSION

Catalog Number
MHL07-L-C-4-U-MB

Type
Z1

Notes

LED MHL LED

Linear LED Lighting for Hazardous Locations

Fixture Dimensions (inches)

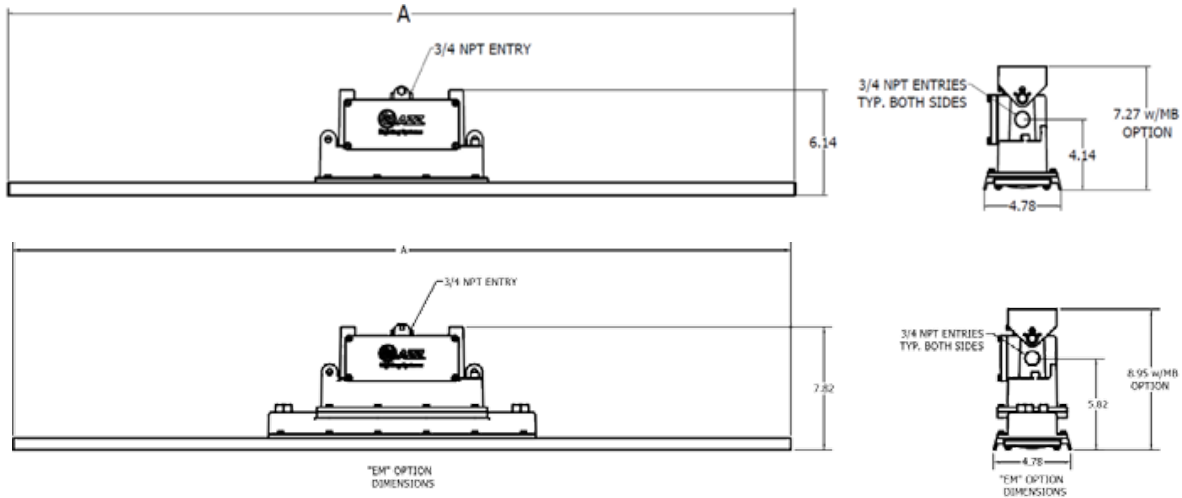

MHL SERIES	Dimensions (inches)	Boxed Weight	Shipping Volume
	A		
4 ft. models	48.00	18 lbs.	1.47 cu. ft.
2 ft. models	24.00	10 lbs.	.76 cu. ft.

Accessories



Mounting Bracket

Ceiling or Wall
Catalog Number: 53050
Shipping Weight: 2 lbs.



End Brackets

Cables or Chain
Catalog Number: 53051
Shipping Weight: 1 lbs.



Beam Clamp

Catalog Number: 38083
Shipping Weight: 1.25 lbs.



Beam Clamp Mounting Kit

Catalog Number: 53010
Shipping Weight: 3 lbs.



Safety Cable

Catalog Number: 10128R
Shipping Weight: 1 lb.

MHL LED

Linear LED Lighting for Hazardous Locations

- Class I, Division 2, Groups A, B, C & D
- Class II, Division 2, Groups F & G
- Class III
- UL 1598A Marine Outside Type
- UL 1598 Wet Locations
- UL 8750 LED Safety
- UL 844 Hazardous Locations
- UL 924 Emergency Lighting
- -40°C to 65°C Ambient Temperature
- CSA C22.2 No. 250.0-08
- CSA C22.2 No. 137-M1981
- NEMA 4X
- IP66
- ETL Listed
- Tested to LM 79 & LM 80



MHL
LED

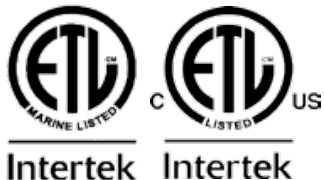

MHL LED

Linear LED Lighting for Hazardous Locations

Key Features:

- 1 Low-profile, lightweight design
- 2 Heavy-duty, 3/8" thick die-cast safety cable attachment points
- 3 Toolless, cage-clamp terminal block
- 4 Captive junction box cover, attached by nylon-coated stainless steel cable
- 5 Field replaceable LED circuit boards and drivers with quick disconnects
- 6 Adjustable mounting bracket with 60° range of motion and nine locking positions*
- 7 Impact resistant clear lens

* Not included, must be ordered separately. Please see options section.



Additional Features:

- Central safety cable attachment points for increased safety/reduced range of motion
- Feed-through capable
- Optional end brackets for chain mount applications
- Emergency battery back-up
- Diffused lens option
- 4kV surge protection (10kV option available)
- 5-year warranty

Standard Materials:

- Body: 6061T5 aluminum (less than .4% copper content) with baked-on gray epoxy finish
- Driver body: A360 aluminum (less than .4% copper content) with baked-on gray epoxy finish
- Gaskets: one-piece neoprene
- Optional end brackets: stainless steel
- Lens: polycarbonate
- Hardware: stainless steel



LED MHL LED

Linear LED Lighting for Hazardous Locations

Catalog Number Logic

MHL 07 - L - C - 4 - U - XX

① ② ③ ④ ⑤ ⑥ ⑦

1 **BASIC SERIES**
MHL Series¹
Hazardous Locations
Class I, Division 2, Groups A, B, C & D
Class II, Division 2, Groups F & G
Class III
UL 1598A Marine Outside Type
UL 844
UL 928
UL 8750 LED
CSA C22.2
NEMA 4X
IP66
ETL Listed

2 **LAMP WATTAGE**
07 = 80 Watt (4 foot)
04 = 40 Watt (2 foot)

3 **LAMP TYPE**
L = LED (4000K CCT)

4 **LENS**
C = Clear
D = Diffused

5 **NOMINAL FIXTURE LENGTH**
2 = 2 Foot
4 = 4 Foot

6 **VOLTAGE/ FREQUENCY**
U = 120 - 277V 50/60HZ
N = 347/480V 60HZ
A = 120V 60HZ²
B = 220 - 240V 50/60HZ²
C = 277V 60HZ²

7 **OPTIONS**
RIG = Mounting Bracket & (2) Safety Cables
MB = Mounting Bracket Ceiling or Wall
EB = End Brackets Cable or Chain Suspension
HA = High Ambient 65°C Rated (4 ft. Model Only)
EM = Emergency Battery Backup
SP = Increased Surge Protection, 10kV (Not available with 347/480V)
FB = Fuse Block (Not Available with 347/480V)²
30 = 3000K CCT
35 = 3500K CCT
50 = 5000K CCT

¹Mounting Hardware not included. Please see options for mounting selections.
²Specify voltage when option FB is needed. When option FB is selected, one fuse is provided for 120 and 277V. Two fuses are provided for 220-240V. Fuse option not available for marine listed fixtures, or for fixtures listed for use in Canada.



Project
MGD EXPANSION

Catalog Number
MHL07-L-C-4-U-MBEM

Type
Z1E

Notes

LED

MHL LED

Linear LED Lighting for Hazardous Locations

Certification Guide

Model	Length	Wattage	Operating Voltage	Total Lumens	Lumen per Watt	CRI	CCT	Comparable Fluorescent Luminaire	Ambient Temperature	Class I, Div. 2, Group A, B, C & D	Class II, Div. 2, Group F & G Class III	Simultaneous Presence	Supply Wire Suitable Temperature, °C
MHL04LC2	2 ft	40W	120V - 277V 50/60 Hz,	4068	101	84	4009	2 X 24W T5H0 / 2 X 35W T12H0	-40°C < Tamb < 55°C	T4A	T4A	T4A	90°C
MHL07LC4	4 ft	80W	347V/480V 60Hz	7654	102	84	4105	2 X 54W T5H0 / 2 X 60W T12H0	-35°C < Tamb < 60°C	T4A	T4A	T4A	90°C
MHL04LD2	2 ft	40W	120V - 277V 50/60 Hz,	3737	93	83	3916	2 X 24W T5H0 / 2 X 35W T12H0	-40°C < Tamb < 55°C	T4A	T4A	T4A	90°C
MHL07LD4	4 ft	80W	347V/480V 60Hz	7453	99	83	4034	2 X 54W T5H0 / 2 X 60W T12H0	-35°C < Tamb < 60°C	T4A	T4A	T4A	90°C
MHL07LC4-HA	4 ft	40W	120V - 277V 50/60 Hz,	7654	102	84	4105	2 X 54W T5H0 / 2 X 60W T12H0	-30°C < Tamb < 65°C	T4A	T4A	T4A	90°C
MHL07LD4-HA	4 ft	80W	347V/480V 60Hz	7453	99	83	4034	2 X 54W T5H0 / 2 X 60W T12H0	-30°C < Tamb < 65°C	T4A	T4A	T4A	90°C

MHL07LC4U

Coefficients of Utilization

% Effective Ceiling Cavity Reflectance rcc	80				70				50				30				10				0
	70	50	30	10	70	50	30	10	50	30	10	50	30	10	50	30	10	50	30	10	0
% Wall Reflectance rw	70	50	30	10	70	50	30	10	50	30	10	50	30	10	50	30	10	50	30	10	0
Room Cavity Ratio RCR	Effective Floor Cavity Reflectance 20%																				
0	119	119	119	119	116	116	116	116	111	111	111	106	106	106	102	102	102	102	102	100	
1	110	105	101	98	107	103	99	96	99	96	93	95	92	90	91	89	88	88	88	85	
2	100	92	86	80	98	90	84	79	87	82	78	84	79	76	81	77	74	74	72	72	
3	91	81	74	67	89	80	73	67	77	71	65	74	69	64	72	67	63	61	61	61	
4	84	72	64	57	82	71	63	57	68	61	56	66	60	55	64	59	54	52	52	52	
5	77	65	56	49	75	63	55	49	61	54	48	59	53	48	58	52	47	45	45	45	
6	71	58	49	43	69	57	49	43	55	48	42	54	47	42	52	46	42	40	40	40	
7	66	53	44	38	64	52	44	38	50	43	38	49	42	37	48	42	37	35	35	35	
8	61	48	40	34	60	47	39	34	46	39	34	45	38	33	44	38	33	31	31	31	
9	57	44	36	31	56	44	36	30	42	35	30	41	35	30	40	34	30	28	28	28	
10	54	41	33	28	53	40	33	28	39	32	27	38	32	27	37	31	27	25	25	25	

Candlepower Distribution

Deg.	0	15	30	45	60	75	90
0	2823	2823	2823	2823	2823	2823	2823
15	2729	2710	2712	2720	2722	2718	2719
25	2514	2529	2533	2537	2537	2514	2540
35	2259	2262	2262	2270	2270	2275	2282
45	1868	1879	1888	1910	1930	1915	1923
55	1400	1405	1418	1444	1460	1444	1449
65	748	737	821	901	934	965	972
75	117	164	450	367	337	381	403
85	29	29	30	32	35	45	56
95	0	0	0	0	0	30	35
105	0	0	0	0	0	0	0

Photometric Data

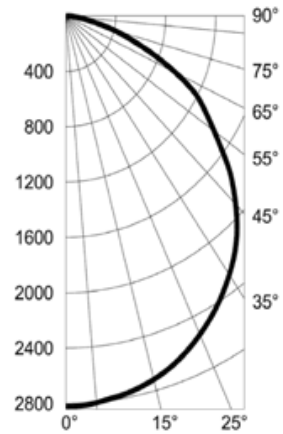

MHL04LC2U

Coefficients of Utilization

% Effective Ceiling Cavity Reflectance rcc	80				70				50				30				10				0
	70	50	30	10	70	50	30	10	50	30	10	50	30	10	50	30	10	50	30	10	0
% Wall Reflectance rw	70	50	30	10	70	50	30	10	50	30	10	50	30	10	50	30	10	50	30	10	0
Room Cavity Ratio RCR	Effective Floor Cavity Reflectance 20%																				
0	119	119	119	119	116	116	116	116	111	111	111	106	106	106	102	102	102	102	102	100	
1	109	104	100	96	106	102	98	94	98	94	91	94	91	89	90	88	86	86	84	84	
2	99	91	84	78	96	89	83	77	85	80	76	82	78	74	79	75	72	70	70	70	
3	90	80	72	65	88	78	71	65	75	69	64	73	67	62	70	65	61	59	59	59	
4	83	71	62	56	81	70	61	55	67	60	54	65	59	54	63	57	53	51	51	51	
5	76	63	55	48	74	62	54	48	60	53	47	58	52	47	56	51	46	44	44	44	
6	70	57	48	42	69	56	48	42	54	47	41	53	46	41	51	45	41	39	39	39	
7	65	52	43	37	64	51	43	37	50	42	37	48	41	36	47	41	36	34	34	34	
8	61	47	39	33	59	47	39	33	45	38	33	44	38	33	43	37	32	31	31	31	
9	57	44	35	30	56	43	35	30	42	35	30	41	34	30	40	34	29	28	28	28	
10	53	40	32	27	52	40	32	27	39	32	27	38	31	27	37	31	27	25	25	25	

Candlepower Distribution

Deg.	0	15	30	45	60	75	90
0	1445	1445	1445	1445	1445	1445	1445
15	1395	1396	1393	1401	1394	1397	1401
25	1308	1309	1305	1313	1308	1311	1311
35	1176	1173	1174	1180	1175	1174	1175
45	998	999	1006	998	995	996	998
55	749	759	773	781	774	771	771
65	505	510	502	501	489	495	499
75	221	215	211	222	198	177	133
85	34	34	13	11	9	8	8
95	13	10	9	8	7	7	7
105	12	0	0	0	0	0	0
115	11	0	0	0	0	0	0

Photometric Data

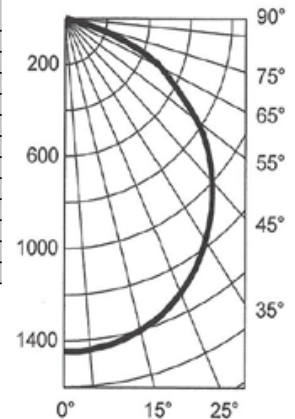



LED MHL LED

Linear LED Lighting for Hazardous Locations

MHL07LD4U

Coefficients of Utilization

% Effective Ceiling Cavity Reflectance rcc	80				70				50				30				10				0
	70	50	30	10	70	50	30	10	70	50	30	10	70	50	30	10	70	50	30	10	0
Room Cavity Ratio RCR	Effective Floor Cavity Reflectance 20%																				
0	119	119	119	119	116	116	116	116	111	111	111	111	106	106	106	106	102	102	102	102	100
1	109	104	100	96	106	102	98	94	98	94	91	94	91	89	90	88	86	86	84	84	84
2	99	91	84	78	96	89	83	77	85	80	76	82	78	74	79	75	72	72	70	70	70
3	90	80	72	65	88	78	71	65	75	69	64	73	67	62	70	65	61	59	59	59	59
4	83	71	62	56	81	70	61	55	67	60	54	65	59	54	63	57	53	51	51	51	51
5	76	63	55	48	74	62	54	48	60	53	47	58	52	47	56	51	46	44	44	44	44
6	70	57	48	42	69	56	48	42	54	47	41	53	46	41	51	45	41	39	39	39	39
7	65	52	43	37	64	51	43	37	50	42	37	48	41	36	47	41	36	34	34	34	34
8	61	47	39	33	59	47	39	33	45	38	33	44	38	33	43	37	32	31	31	31	31
9	57	44	35	30	56	43	35	30	42	35	30	41	34	30	40	34	29	28	28	28	28
10	53	40	32	27	52	40	32	27	39	32	27	38	31	27	37	31	27	25	25	25	25

Candlepower Distribution

Deg.	0	15	30	45	60	75	90
0	2836	2836	2836	2836	2836	2836	2836
15	2687	2679	2682	2683	2679	2672	2671
25	2424	2427	2428	2430	2424	2415	2414
35	2098	2094	2093	2090	2084	2072	2070
45	1715	1713	1710	1700	1694	1679	1679
55	1317	1313	1309	1295	1280	1264	1260
65	928	925	920	909	889	868	859
75	498	502	501	494	478	455	440
85	77	80	88	96	98	103	93
95	0	0	0	0	0	26	27
105	0	0	0	0	0	0	0

Photometric Data

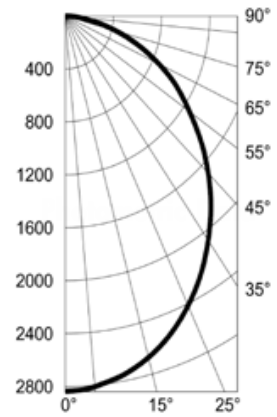

MHL04LD2U

Coefficients of Utilization

% Effective Ceiling Cavity Reflectance rcc	80				70				50				30				10				0
	70	50	30	10	70	50	30	10	70	50	30	10	70	50	30	10	70	50	30	10	0
Room Cavity Ratio RCR	Effective Floor Cavity Reflectance 20%																				
0	119	119	119	119	116	116	116	116	111	111	111	111	106	106	106	106	102	102	102	102	100
1	109	104	99	96	106	101	98	94	97	94	91	93	91	88	90	87	85	83	83	83	83
2	99	90	84	78	96	89	82	77	85	80	75	82	77	73	78	75	72	69	69	69	69
3	90	79	71	65	88	78	70	64	75	68	63	72	66	62	69	65	61	58	58	58	58
4	82	70	62	55	80	69	61	54	67	59	54	64	58	53	62	57	52	50	50	50	50
5	76	63	54	48	74	62	53	47	60	52	46	58	51	46	56	50	45	43	43	43	43
6	70	57	48	41	68	56	47	41	54	46	41	52	45	40	51	45	40	38	38	38	38
7	65	51	43	37	63	51	42	36	49	42	36	48	41	36	46	40	36	34	34	34	34
8	61	47	39	33	59	46	38	33	45	38	32	44	37	32	42	36	32	30	30	30	30
9	57	43	35	29	55	43	35	29	41	34	29	40	34	29	39	33	29	27	27	27	27
10	53	40	32	27	52	39	32	27	38	31	27	37	31	26	36	31	26	24	24	24	24

Candlepower Distribution

Deg.	0	15	30	45	60	75	90
0	1373	1373	1373	1373	1373	1373	1373
15	1303	1304	1304	1311	1306	1309	1312
25	1183	1185	1187	1195	1192	1196	1198
35	1021	1021	1027	1035	1037	1041	1043
45	827	831	842	850	856	861	863
55	624	631	646	656	664	670	672
65	423	432	448	460	467	471	472
75	229	239	254	263	268	269	270
85	54	64	64	59	60	62	64
95	11	11	10	8	7	7	6
105	0	0	0	0	0	0	0

Photometric Data

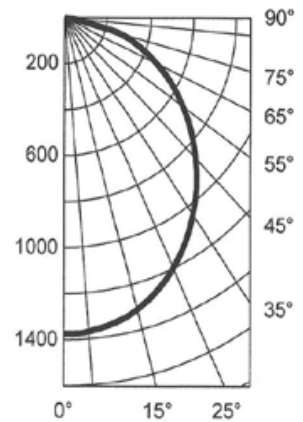



Project
MGD EXPANSION

Catalog Number
MHL07-L-C-4-U-MBEM

Type
Z1E

Notes

LED MHL LED

Linear LED Lighting for Hazardous Locations

Fixture Dimensions (inches)

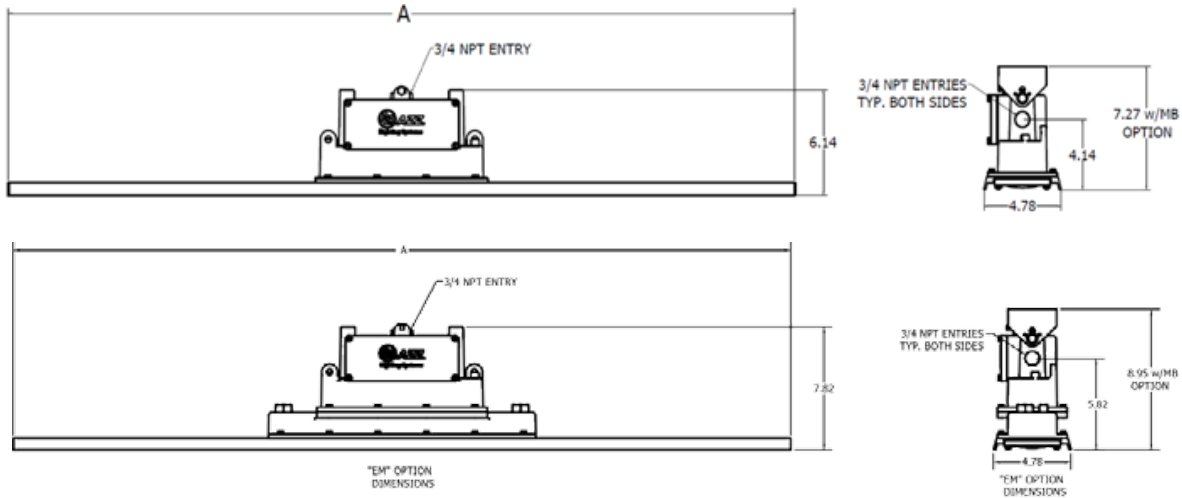

MHL SERIES	Dimensions (inches)	Boxed Weight	Shipping Volume
	A		
4 ft. models	48.00	18 lbs.	1.47 cu. ft.
2 ft. models	24.00	10 lbs.	.76 cu. ft.

Accessories



Mounting Bracket

Ceiling or Wall
Catalog Number: 53050
Shipping Weight: 2 lbs.



End Brackets

Cables or Chain
Catalog Number: 53051
Shipping Weight: 1 lbs.



Beam Clamp

Catalog Number: 38083
Shipping Weight: 1.25 lbs.



Beam Clamp Mounting Kit

Catalog Number: 53010
Shipping Weight: 3 lbs.



Safety Cable

Catalog Number: 10128R
Shipping Weight: 1 lb.

Johnson, Estell/WIC

To: Landman, Jim/DEN
Subject: FW: Four Mile Creek [EXTERNAL]

Type EX: Mule ARS-B-1/2-R-AA
http://mulelighting.com/new_EZSpec/ARRIS_SPECIFICATION.pdf

Type EXZ: Sure-lites UX7-1-00-R-HAZ
http://secure-web.cisco.com/1OQWC1F-Y2hIh-ELlkvzBUXzn37PMV60QFafr8dWdmVxcHFLSj_j7AoNSHXEcLGUj4l7be7SB0hKo-izVcTtbtzAluB_nEOA-kH919hIRVDi2UnnxEclR65xFVnbOW4qYTHPfrE0YVKxIfkIP71pPYloXsX8eYZ75XT20z2iNtXy-MpkboAMma9RWRWkwB5Cu8LsbiHTDPaxeukC5zSUw0KPqUUOmu-PylOmbW7-xT5E3zPHnl6eiBaEx2_FVqGjYBntZTLuiKqkUWPazcSpJQ8sQbTPguJrvlrTWYSJxvOwAlmXcLRv7Ss6GJ7Pa2uvKZA2vk9dW6C9A8u7iuH4aHHnTuUGk4xEwd8aJgcf_ZycvNtpNcT1cY7NCOV7CRuogLK8crVrtXIR1TRYff5GLdyJs3Qm9hQFrK3LjjZqMPU_0FNZEHW1N7Z4uexCctUjD2xkcgDlwJYqY0f01dc3HjQXLV2cTgAHXwLnTjG1sho/http%3A%2F%2Fwww.cooperindustries.com%2Fcontent%2Fdam%2Fpublic%2Fighting%2Fproducts%2Fdocuments%2Fsure_lites%2Fspec_sheets%2Fsure-lites-uxseries-selfpowered-adx041004-sss.pdf

Type EL: Mule PTR-12-42-MR16LED-AT-IH
http://mulelighting.com/new_EZSpec/PTR_SPECIFICATION.pdf

Type W1: McGraw GWC-AF-01-LED-E1-T3-BZ-7050
http://secure-web.cisco.com/13NkL7tFpITezRXJ1A29-ys9kmRorLEBh9C7mmtZ_Wi9Q18QsQs3ykTK8ki4QNN6V98j3MF6Y7CBwXK3KUEOnVFqMJ6LTBgclLVHgrBcBBdFDrmvnQgSCcDrFoyaPbgJcGq3U_0grmOcUZukjNjxV8_rMSGcXiirVmsaQYdo72sBhnK4kCIEI4fLHI3x6FshQ7V_5EFlukbm3ibMZoOLZY5y5lriXFMCSYtQtoPlpCse3w0xpwe1lv4WhOz18Gm0KngMf0Pc5uh6ZQduB9wwP9ReAA3GibhctVQlyxUTon_jya7hJCHzIAldUX_Nqy4n7Ws_NSKsUIDmWMMRyPcmU6X5epDIbNd9QYTx8RHY6mcWW5PVaN1nMGFXV-TSNqHMN8jENSge-wwN4-EpZ1Tgs163x12uqeo2mAFVHfUq9flryKWAPhloOp4m4MFNaMgRChPRTsCXweNFj7Y_R8a3NMBtGJZX70fkpluyX6gSk/http%3A%2F%2Fwww.cooperindustries.com%2Fcontent%2Fdam%2Fpublic%2Fighting%2Fproducts%2Fdocuments%2Fmcgraw_edison%2Fspec_sheets%2Fmcgraw-edison-gwc-galleon-wall-led-td514017en-sss.pdf

Type P1: McGraw GPC-AF-01-LED-E1-T2-BZ-QM-7050
http://secure-web.cisco.com/1PhV-nqHuJcxdALVaW9SynEd_I5pKrnwN4HBv1vCeTHM8mvlRYupQ5n-o9cMATMSFzJuyqBXN4vm4eQcC_omx5W4hwKFj34iCJl1YtZD_RyYUltrmDxEbU9ZwHDku2mJ1wFCpk7-tUlk-FoxEePI2CS4YPhTrgSdSovYELoAg2So25JjmYW_L8L2eJTzclLFHMztlfxc3_XDOa_DhptV0H4W5GwFn8nsVMPuDKtLkP2u9Uk_rMqr_OtuFFMHsfDy3dpjiZ8-E6eRuNTCGEX4WUd4gQaZcJj3T_r1eotFGJDAF6R1kyNfQ0EF3bjwK8_tfFafDSE0MnBP37BrmLepsVvIGbCHSTFLtm-r7h1etNMb3CokJ_HOyUwJZaGmCB-Uvtlr5ltCljPhZHfdx0ZZrtNzlixTrTnBwlErH2ppiZe1xu9SocRbZmokl6lci886CSMgJyCQV0fHG-d_Ce7str3eN0p9ESNh5QJBa-AGg/http%3A%2F%2Fwww.cooperindustries.com%2Fcontent%2Fdam%2Fpublic%2Fighting%2Fproducts%2Fdocuments%2Fmcgraw_edison%2Fspec_sheets%2Fmcgraw-edison-gpc-galleon-wall-led-td500053en-sss.pdf

Type P1 POLE: McGraw SSA4-M-10
http://secure-web.cisco.com/1RXx8vR_NV30piK3MPcL8BUvMQn29SrpECsTEj70y1UNVKmgmdj8kXjtf92IS-OZ4iTWS2laJ2uyO6dlFSMj3x3mCnX_W1TTS1XNf05jra7MR7NE3KWN7w4rWtSKaPAL6zVjBXU3DJf5yuxoZRnn6OBX2t2meSp9Ya2EfSGr68DWPTIXyD82ULhb0NDNP1n7Ub_qWRKqHO7O_QeZYyNBjhbwoqgvTdu9pxjWJEU28YM2pYbXmlosZhM_YVfxA5y7ke0mjABQAnDkROodLdArWf0_AR7CWav6G_WRGdxgFPVlq1DHHxxE-9gL-2rtsSKbObLeQJGSYGPV-

[kyHBZnpMQ8BhK--](#)

[OFmXj4S22Gb7T3Na5eWzF1cLlhaaOznblrEaV9gPMCZThCArtEuGlkrCyXe3K3gSRBYM3EwASMB2hxDX6Wx_Oh7qqYxvxyD7XaYbuk8OQ5fPmkE0tUa_ar4w6XR6dviUq43PAA3hlxoQBCs/http%3A%2F%2Fwww.cooperindustries.com%2Fcontent%2Fdam%2Fpublic%2Flighting%2Fproducts%2Fdocuments%2Fpoles%2Fspec_sheets%2Fpoles-ssa-td513009en-sss.pdf](#)

Thanks,

Brady Yust

 **mercerzimmerman**

o. 316-267-2329 | byust@mzltg.com | www.mzltg.com

245 N. Waco St., Ste. 510, Wichita, KS 67202-1118

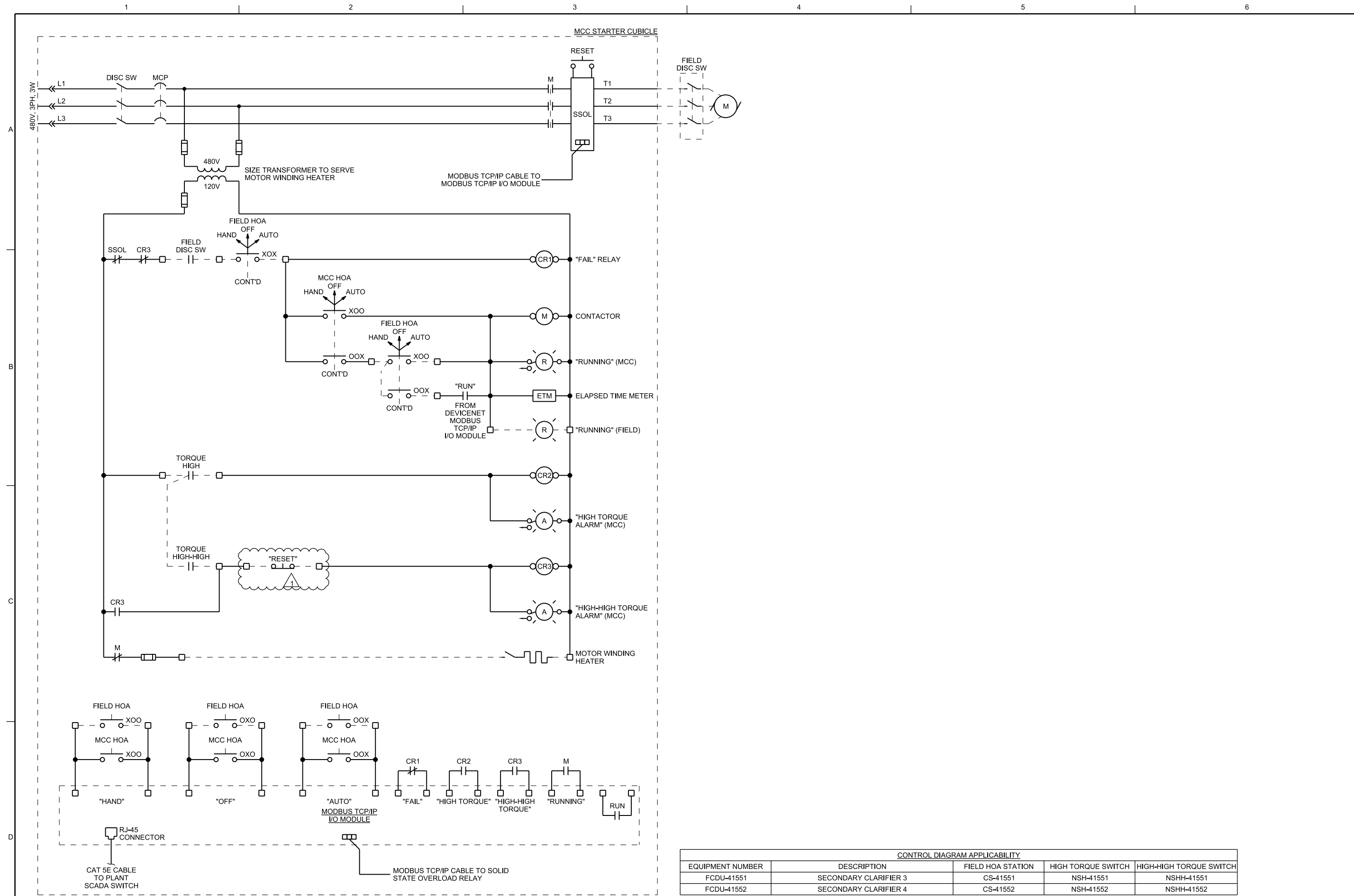

CONTROL DIAGRAM

CONTROL DIAGRAM APPLICABILITY				
EQUIPMENT NUMBER	DESCRIPTION	FIELD HOA STATION	HIGH TORQUE SWITCH	HIGH-HIGH TORQUE SWITCH
FCDU-41551	SECONDARY CLARIFIER 3	CS-41551	NSH-41551	NSHH-41551
FCDU-41552	SECONDARY CLARIFIER 4	CS-41552	NSH-41552	NSHH-41552

SITE ELECTRICAL

MOTOR CONTROL DIAGRAMS

PHASE II, 6 MGD EXPANSION
FOUR MILE CREEK WQRF
DEPARTMENT OF PUBLIC WORKS
CITY OF WICHITA, KANSAS

NO.	DATE	REVISION	BY	APVD
1	12/22/16	ADDENDUM NO. 3	JL	MG
0	12/16/16	ADDENDUM NO. 2	JL	MG

DR	CHK	APVD	M. GROSS
J. LANDMAN	A. CUGLIATI		

VERIFY SCALE
BAR IS ONE INCH ON ORIGINAL DRAWING.

DATE	DECEMBER 2016
PROJ	496312
DWG	080-E-6202
SHEET	123b of 314

DESIGN DEVELOPMENT

REUSE OF DOCUMENTS: THIS DOCUMENT AND THE IDEAS AND DESIGNS INCORPORATED HEREIN, AS AN INSTRUMENT OF PROFESSIONAL SERVICE, IS THE PROPERTY OF CH2M HILL AND IS NOT TO BE USED, IN WHOLE OR IN PART, FOR ANY OTHER PROJECT WITHOUT THE WRITTEN AUTHORIZATION OF CH2M HILL. © CH2M HILL 2016. ALL RIGHTS RESERVED.

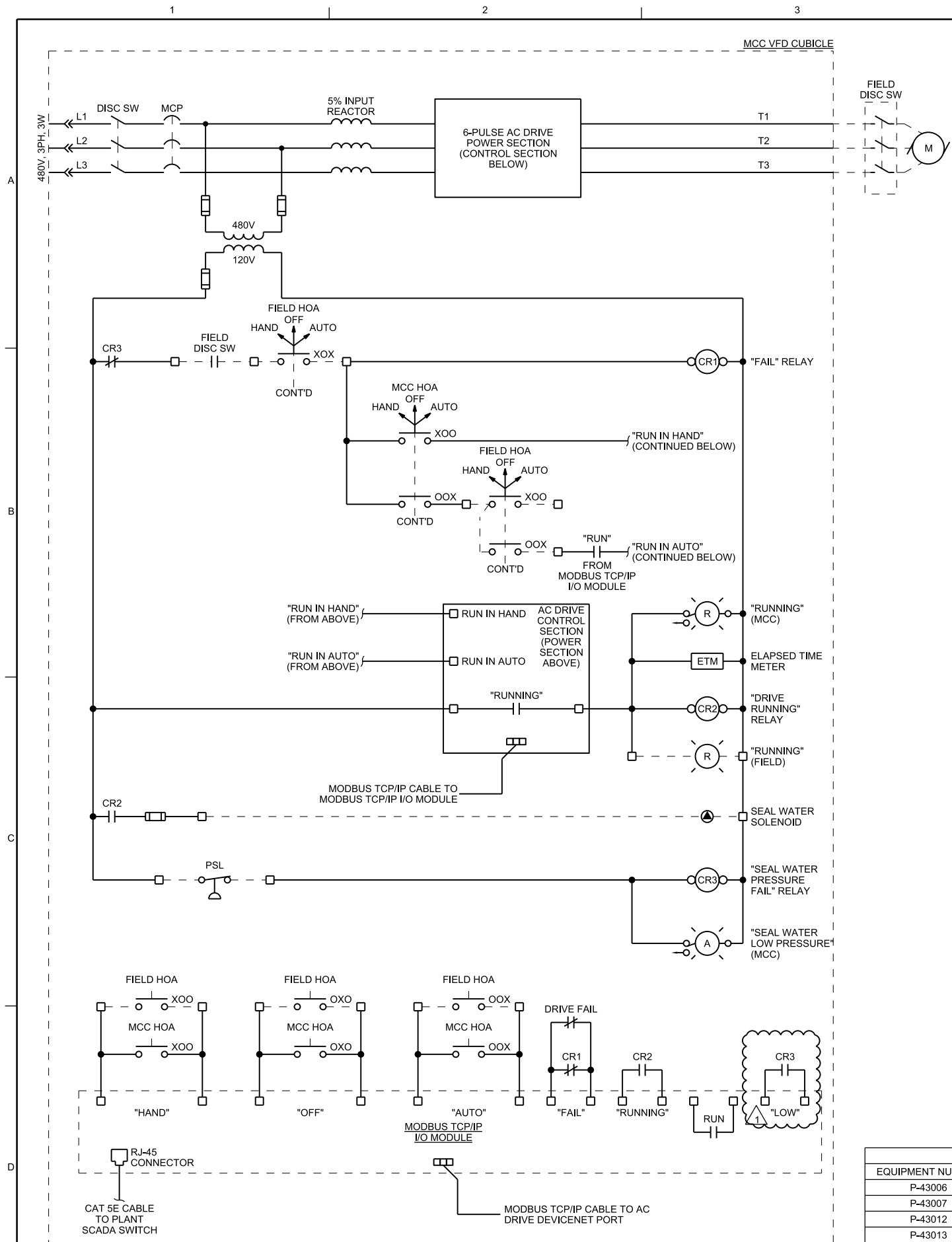

CONTROL DIAGRAM

CONTROL DIAGRAM APPLICABILITY		
EQUIPMENT NUMBER	DESCRIPTION	FIELD HOA STATION
P-43006	RAS PUMP NO. 1	CS-43006
P-43007	RAS PUMP NO. 2	CS-43007
P-43012	RAS PUMP NO. 3	CS-43012
P-43013	RAS PUMP NO. 4	CS-43013

- NOTES:
- WHEN DRIVE IS OPERATING IN "HAND", SPEED IS SET FROM HMI AT THE DRIVE.
 - WHEN DRIVE IS OPERATING IN "AUTO", SPEED IS SET FROM MODBUS TCP/IP SIGNAL FROM PLANT SCADA SYSTEM.

SITE ELECTRICAL

MOTOR CONTROL DIAGRAMS

PHASE II, 6 MGD EXPANSION
FOUR MILE CREEK WORF
DEPARTMENT OF PUBLIC WORKS
CITY OF WICHITA, KANSAS

NO.	DATE	REVISION	BY	APVD
1	12/16/16	ADDENDUM NO. 3	JL	MG
0		ADDENDUM NO. 2	JL	MG

DR	CHK	APVD	M. GROSS
J. LANDMAN	A. CUGLIATI		M. GROSS

VERIFY SCALE
BAR IS ONE INCH ON ORIGINAL DRAWING.

DATE	DECEMBER 2016
PROJ	496312
DWG	080-E-6204
SHEET	123d of 314

DESIGN DEVELOPMENT

REUSE OF DOCUMENTS: THIS DOCUMENT, AND THE IDEAS AND DESIGNS INCORPORATED HEREIN, AS AN INSTRUMENT OF PROFESSIONAL SERVICE, IS THE PROPERTY OF CH2M HILL AND IS NOT TO BE USED, IN WHOLE OR IN PART, FOR ANY OTHER PROJECT WITHOUT THE WRITTEN AUTHORIZATION OF CH2M HILL. © CH2M HILL 2016. ALL RIGHTS RESERVED.

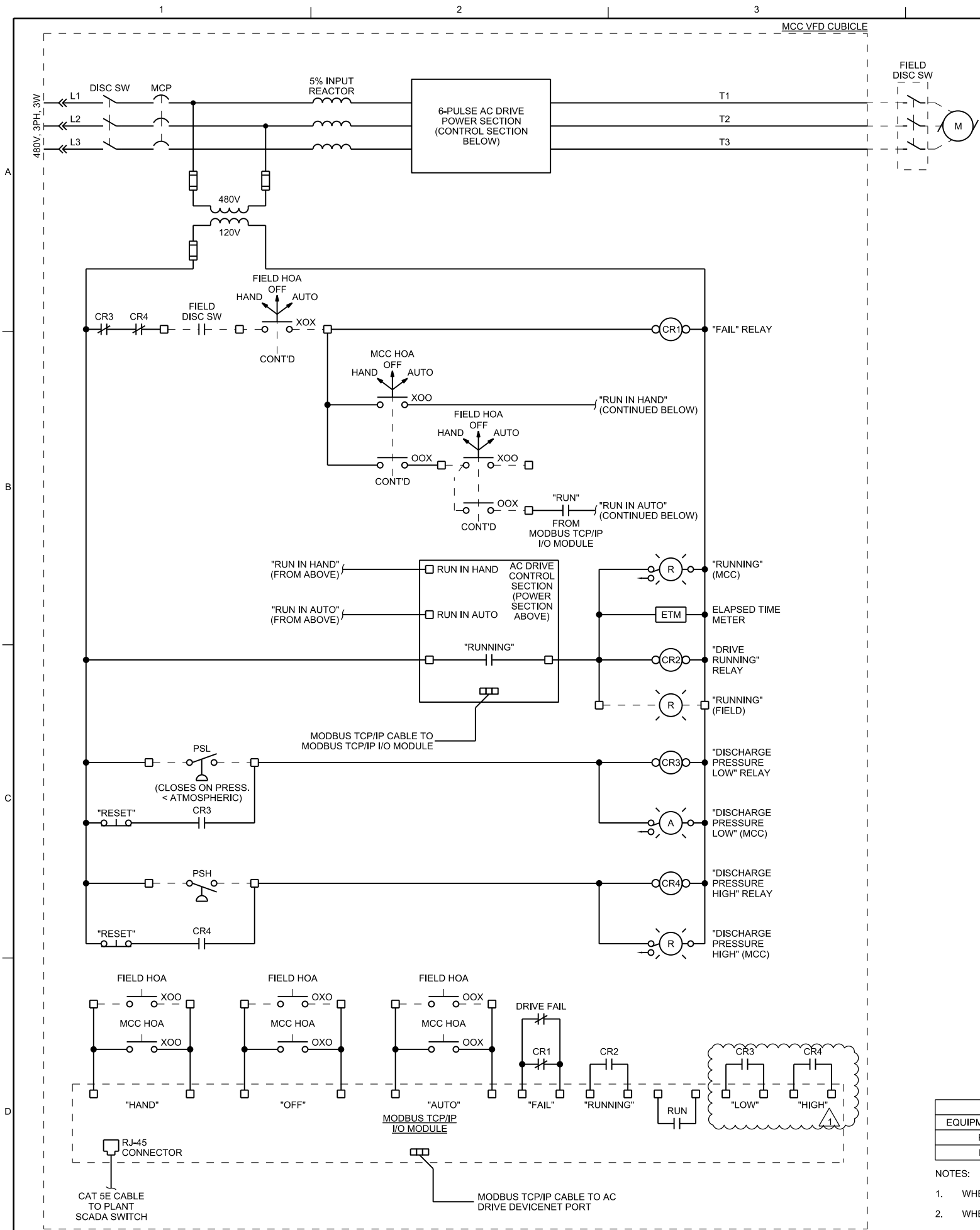

CONTROL DIAGRAM

CONTROL DIAGRAM APPLICABILITY				
EQUIPMENT NUMBER	DESCRIPTION	FIELD HOA STATION	LSL	LSH
P-43010	DIGESTED SLUDGE PUMP NO. 1	CS-43010	PSL-43017	PSH-43017
P-43011	DIGESTED SLUDGE PUMP NO. 2	CS-43011	PSL-43519	PSH-43519

- NOTES:
- WHEN DRIVE IS OPERATING IN "HAND", SPEED IS SET FROM HMI AT THE DRIVE.
 - WHEN DRIVE IS OPERATING IN "AUTO", SPEED IS SET FROM MODBUS TCP/IP SIGNAL FROM PLANT SCADA SYSTEM.
 - FIELD HOA STATIONS AND PRESSURE SWITCHES EXIST. PROVIDE WIRING AS INDICATED IN THIS CONTROL DIAGRAM.

SITE ELECTRICAL

MOTOR CONTROL DIAGRAMS

PHASE II, 6 MGD EXPANSION
FOUR MILE CREEK WORTH
DEPARTMENT OF PUBLIC WORKS
CITY OF WICHITA, KANSAS

NO.	DATE	REVISION	BY	APVD
1	12/22/16	ADDENDUM NO. 3	MG	M GROSS
0	12/16/16	ADDENDUM NO. 2	JL	MG

DR	CHK	APVD	M GROSS
J LANDMAN	A CUGLIATI	APVD	M GROSS

VERIFY SCALE
BAR IS ONE INCH ON ORIGINAL DRAWING.

DATE	DECEMBER 2016
PROJ	496312
DWG	080-E-6205
SHEET	123e of 314

DESIGN DEVELOPMENT

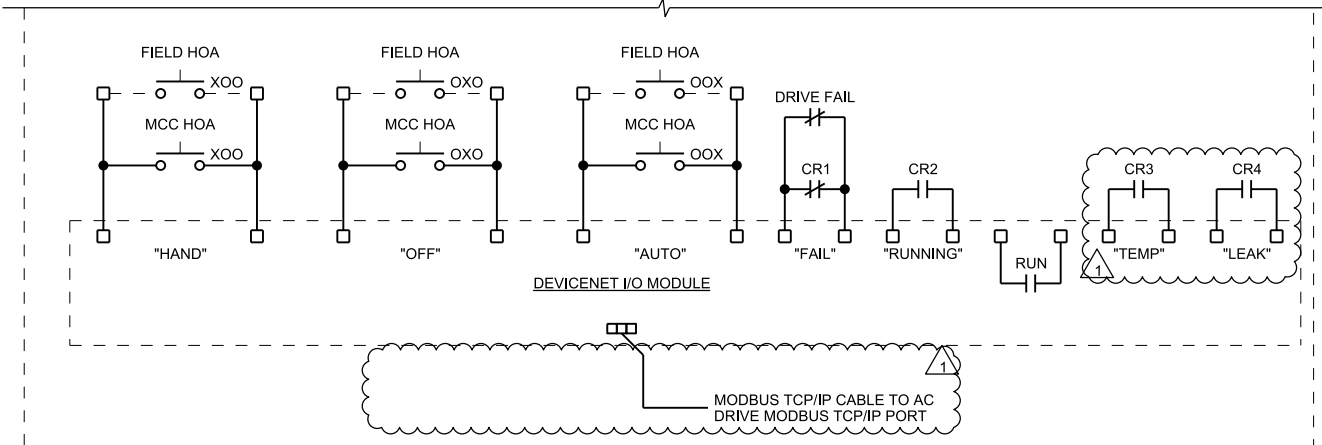
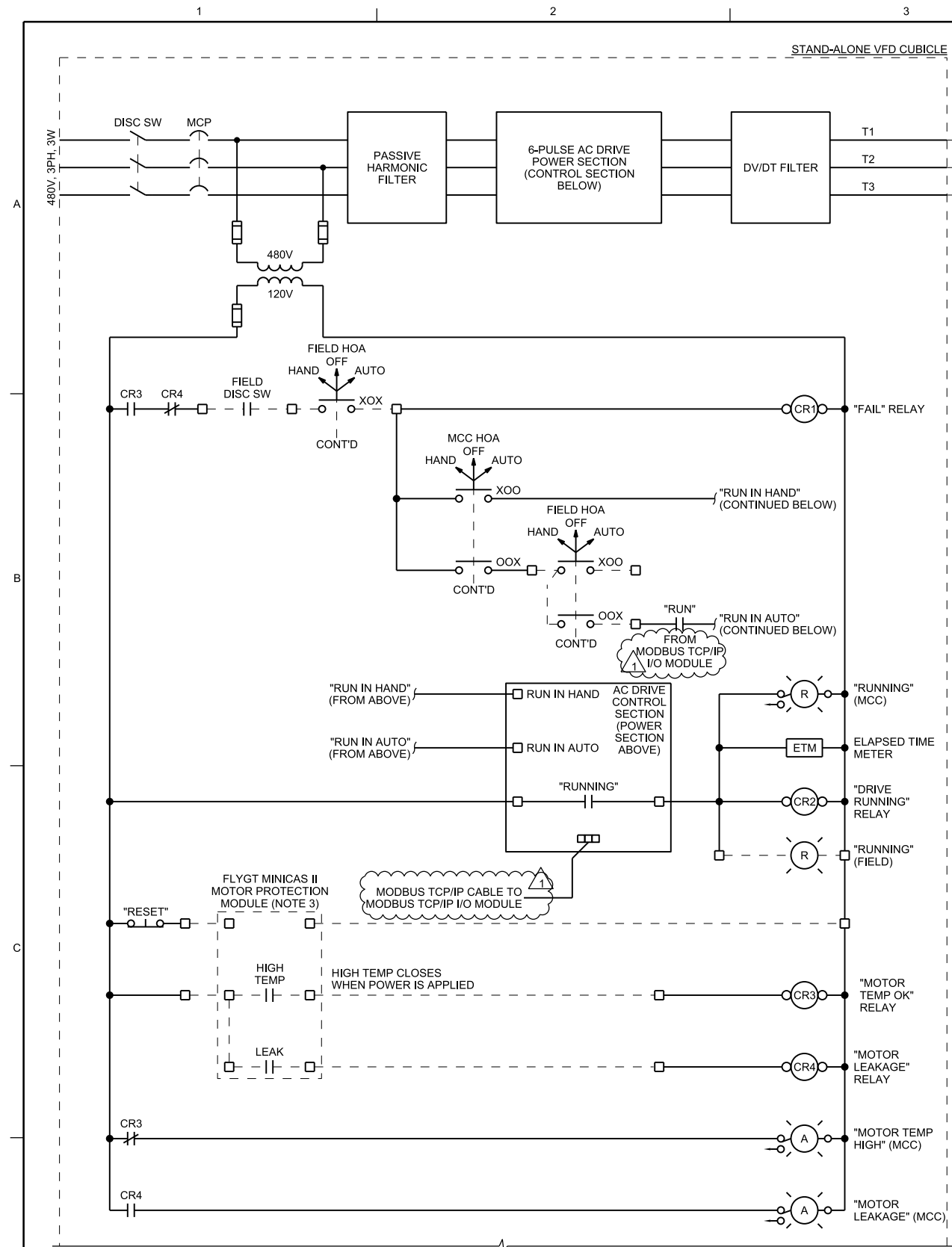

CONTROL DIAGRAM APPLICABILITY				
EQUIPMENT NUMBER	DESCRIPTION	FIELD HOA STATION	TSH	LEAK
P-41051	RAW INFLUENT PUMP 4	CS-41051	TSH-41051	XSH-41051
P-41052	RAW INFLUENT PUMP 5	CS-41052	TSH-41052	XSH-41052
P-41053	RAW INFLUENT PUMP 6	CS-41053	TSH-41053	XSH-41053
P-41054	RAW INFLUENT PUMP 7	CS-41054	TSH-41054	XSH-41054

- NOTES:
- WHEN DRIVE IS OPERATING IN "HAND", SPEED IS SET FROM HMI AT THE DRIVE.
 - WHEN DRIVE IS OPERATING IN "AUTO", SPEED IS SET FROM DEVICENET SIGNAL FROM PLANT SCADA SYSTEM.
 - TEMPERATURE AND LEAKAGE PROBES ARE NOT SHOWN HERE FOR CLARITY.

CONTROL DIAGRAM

PHASE II, 6 MGD EXPANSION
FOUR MILE CREEK WORTH
DEPARTMENT OF PUBLIC WORKS
CITY OF WICHITA, KANSAS

REVISION NO. DATE BY APVD

1	12/22/16	ADDENDUM NO. 3	DT	JL	MG
0	12/16/16	ADDENDUM NO. 2	JL	MG	BY

DR A CUGLIATI M GROSS
DGSN J LANDMAN M GROSS

ch2m
SITE ELECTRICAL

MOTOR CONTROL DIAGRAMS

VERIFY SCALE
BAR IS ONE INCH ON ORIGINAL DRAWING.

DATE DECEMBER 2016
PROJ 496312
DWG 080-E-6207
SHEET 123g of 314

FILENAME: 080-E-6207_496312.dgn

PLOT DATE: 12/22/2016
PLOT TIME: 3:51:43 PM

DESIGN DEVELOPMENT

THIS DOCUMENT, AND THE IDEAS AND DESIGNS INCORPORATED HEREIN, AS AN INSTRUMENT OF PROFESSIONAL SERVICE, IS THE PROPERTY OF CH2M HILL AND IS NOT TO BE USED, IN WHOLE OR IN PART, FOR ANY OTHER PROJECT WITHOUT THE WRITTEN AUTHORIZATION OF CH2M HILL. © CH2M HILL 2016. ALL RIGHTS RESERVED.

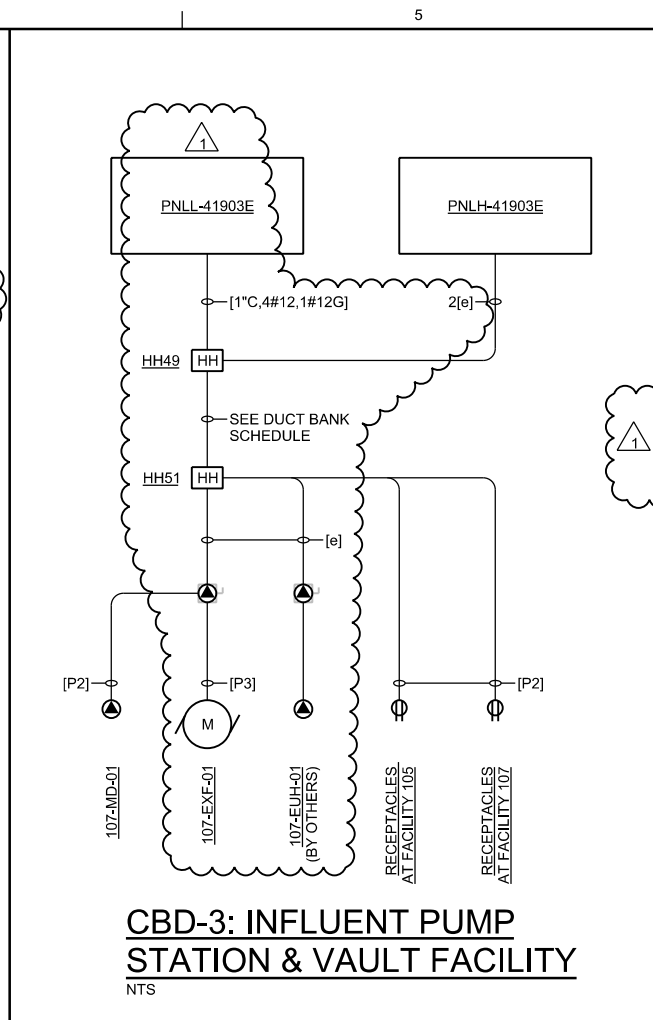
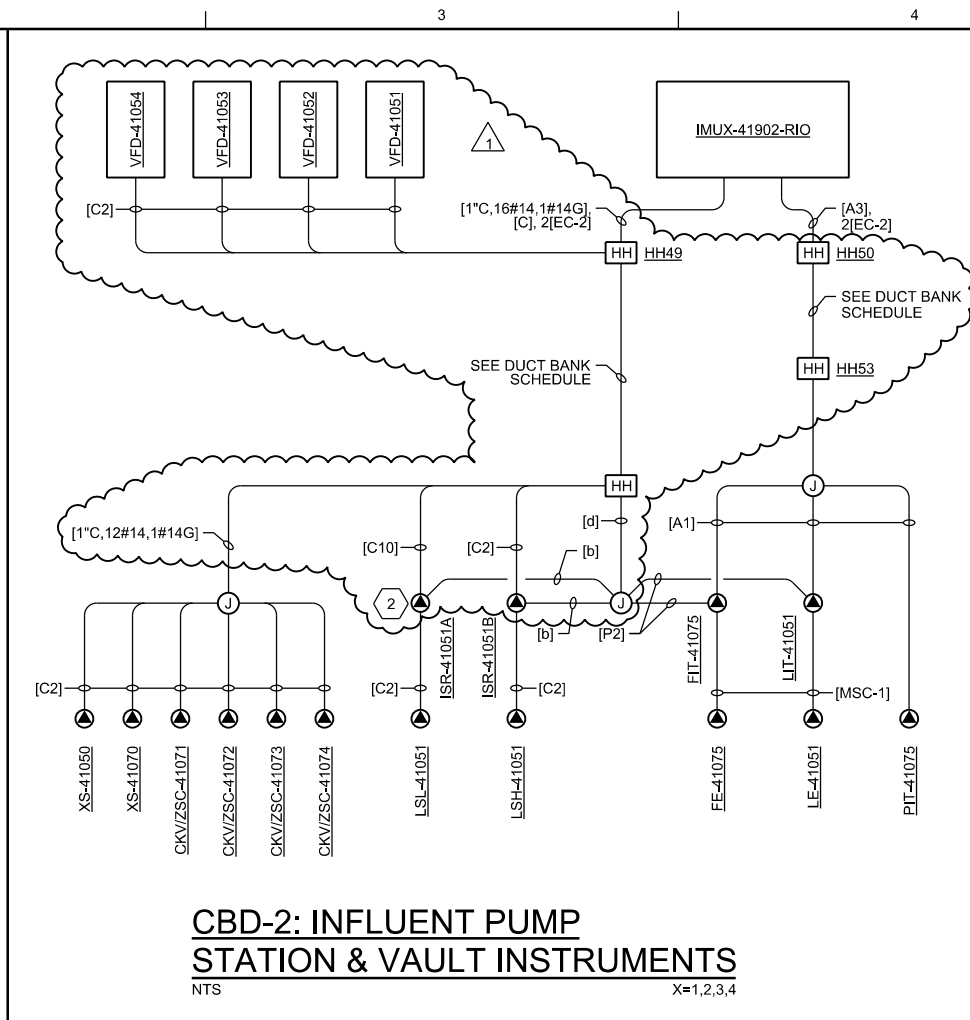
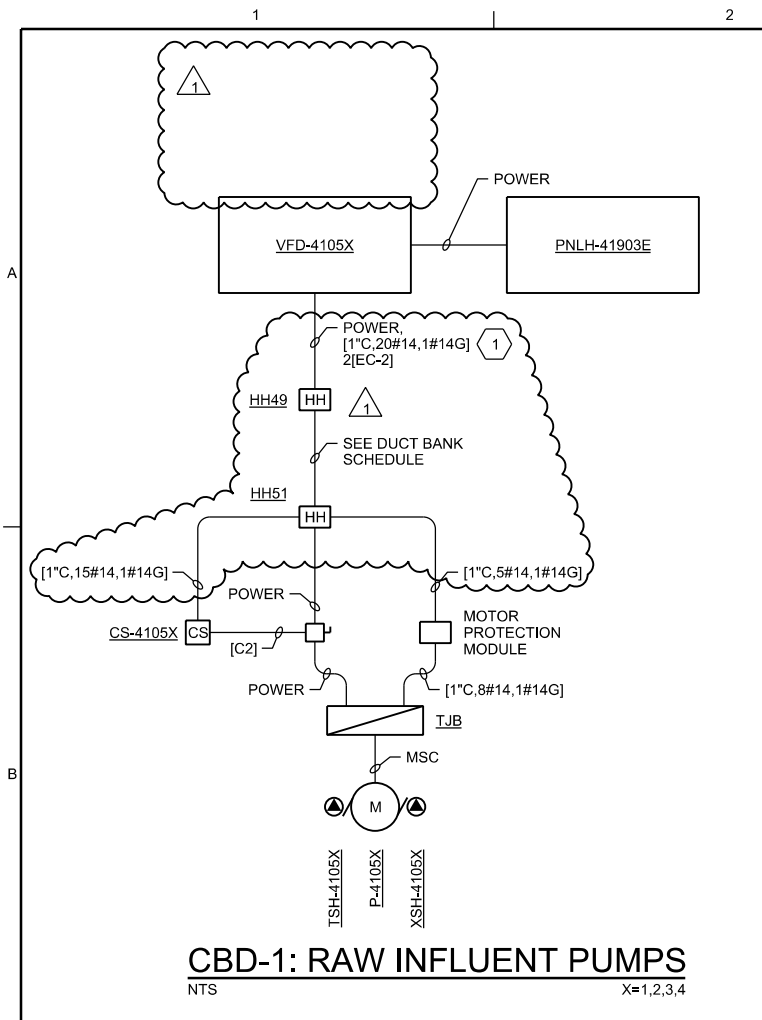

SHEET KEYNOTES

- STUB UP SPARE CONDUITS IN ELECTRICAL ROOM AT FACILITY 110 NEAR VFD'S AND PNLH-41903E.
- ISR-41051A SHALL HAVE FIVE (5) CONTACT OUTPUTS: ONE TO IMUX-41902-RIO, AND ONE TO EACH INFLUENT PUMP DRIVE.
- DISCONNECT SWITCHES AND COMBINATION STARTERS PROVIDED UNDER DIVISION 23, BUILDING MECHANICAL. INSTALLATION BY DIVISION 26, ELECTRICAL.

CONDUIT CALLOUTS
(THIS DWG ONLY)

(1)

[a] = 1" C, 8#14, 1#14G
[b] = 1" C, 2#12, 1#12G
[c] = 1" C, 8#12, 1#12G
[d] = 1" C, 8#12, 1#12G
[e] = 1" C, 3#10, 1#10G
[g] = 1" C, 2#12, 2#14, 1#12G

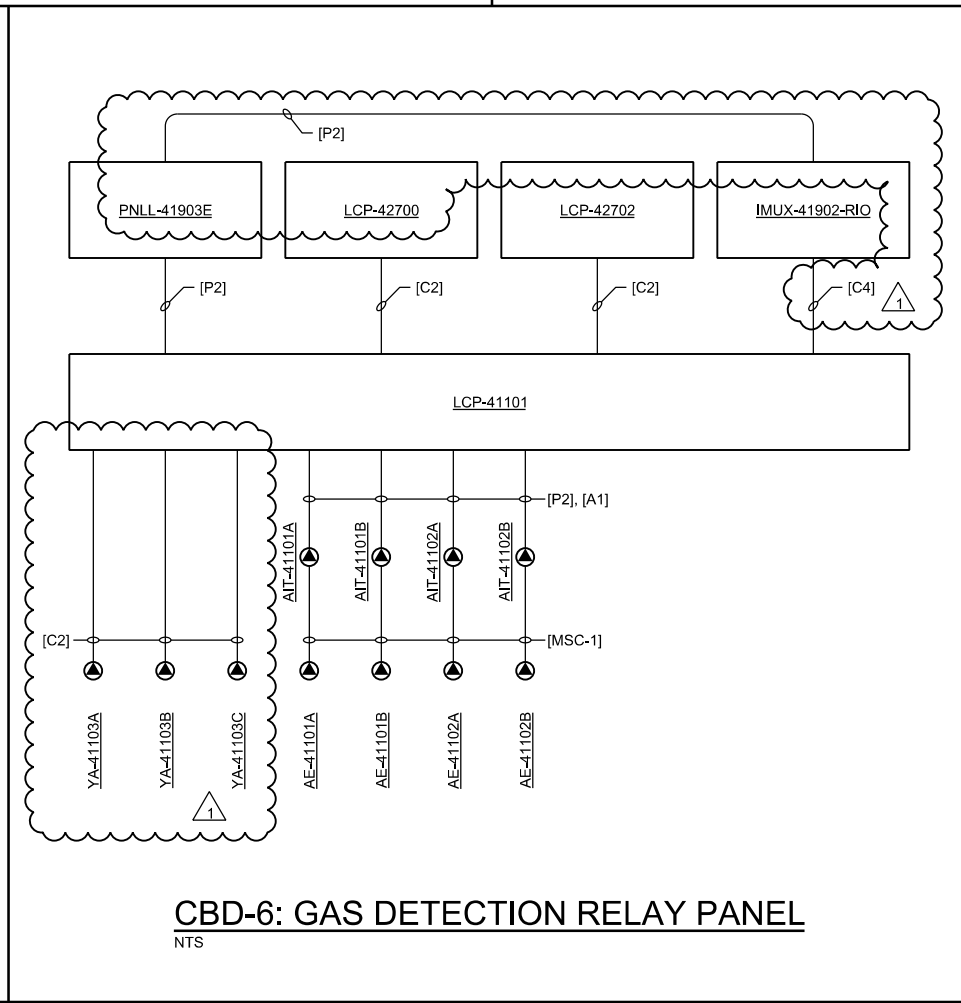
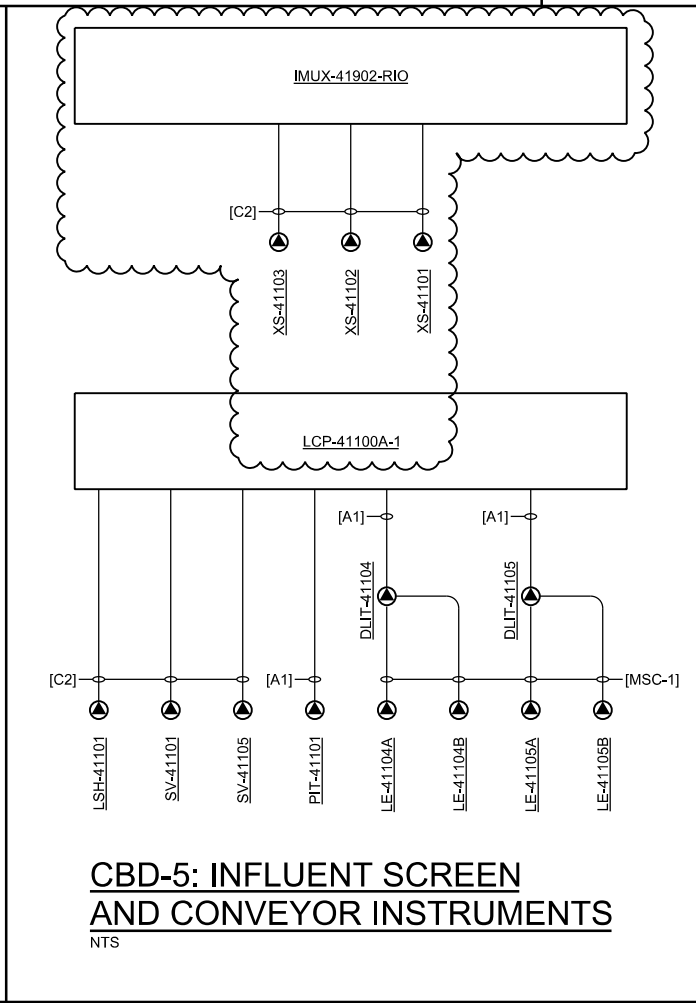
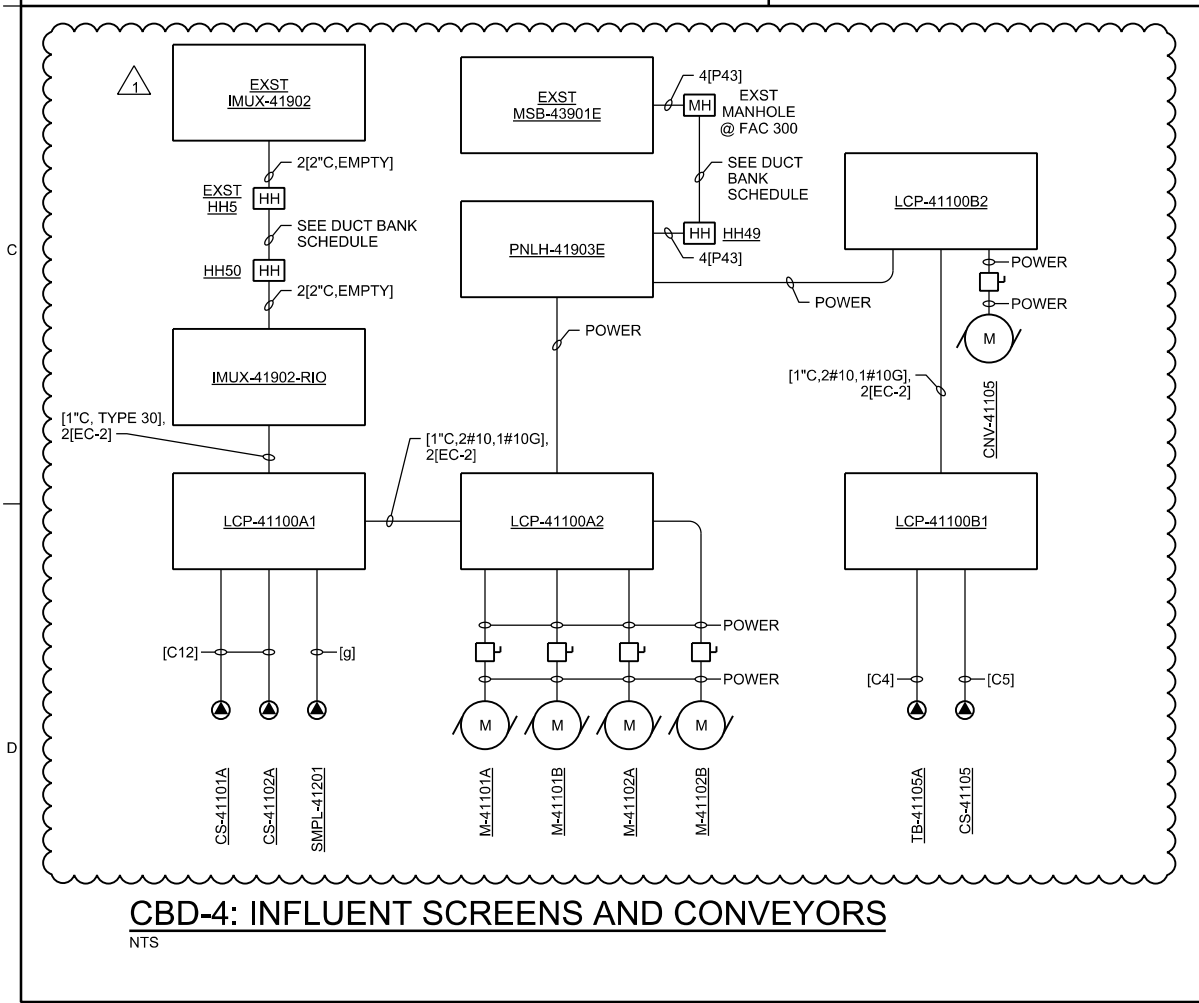

ch2m
SITE ELECTRICAL

PHASE II, 6 MGD EXPANSION
FOUR MILE CREEK WORK
DEPARTMENT OF PUBLIC WORKS
CITY OF WICHITA, KANSAS

CABLE BLOCK DIAGRAMS 1

NO.	DATE	REVISION	CHK	APVD
1	12/23/16	ADDENDUM NO. 3	J. LANDMAN	M. GROSS

VERIFY SCALE
BAR IS ONE INCH ON ORIGINAL DRAWING.
DATE: DECEMBER 2016
PROJ: 496312
DWG: 080-E-6301
SHEET: 124 of 314

REUSE OF DOCUMENTS: THIS DOCUMENT AND THE IDEAS AND DESIGNS INCORPORATED HEREIN, AS AN INSTRUMENT OF PROFESSIONAL SERVICE, IS THE PROPERTY OF CH2M HILL AND IS NOT TO BE USED, IN WHOLE OR IN PART, FOR ANY OTHER PROJECT WITHOUT THE WRITTEN AUTHORIZATION OF CH2M HILL. © CH2M HILL 2016. ALL RIGHTS RESERVED.

BIDDING SET

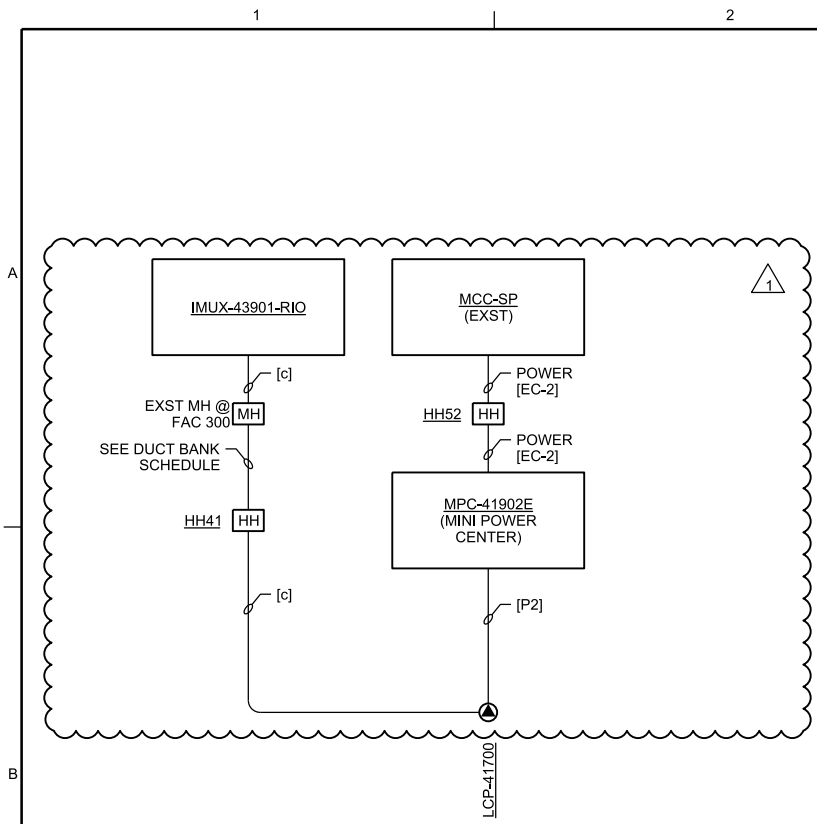

CBD-14: FERRIC CHLORIDE METERING PUMP
NTS X=1,2

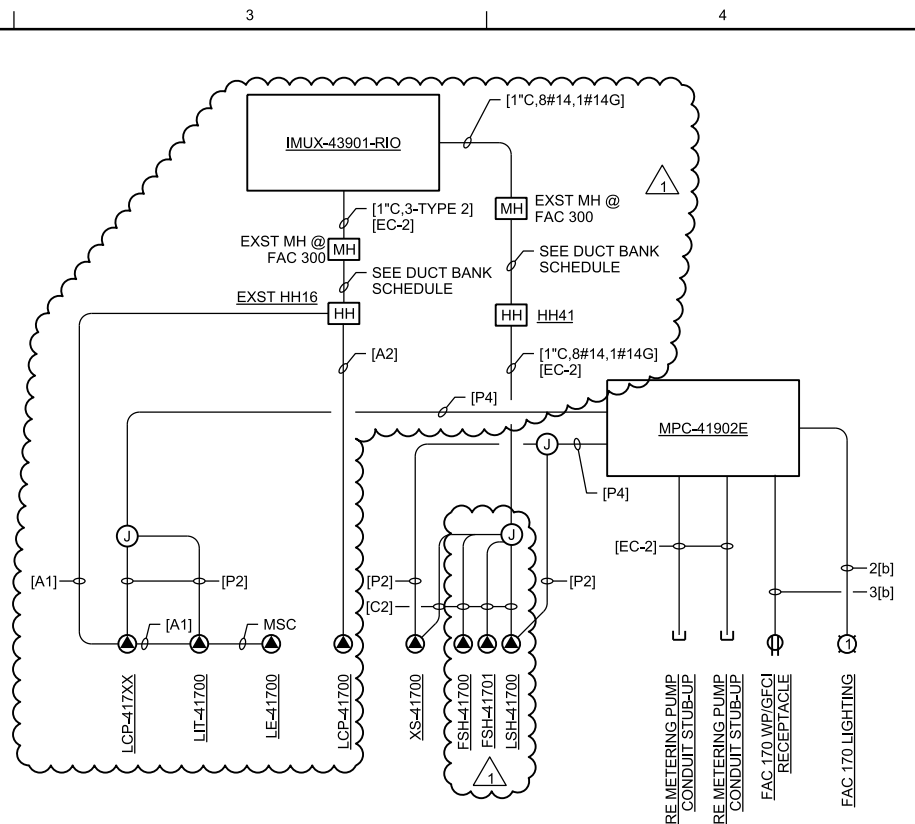

CBD-15: FERRIC CHLORIDE INSTRUMENT & FACILITY
NTS

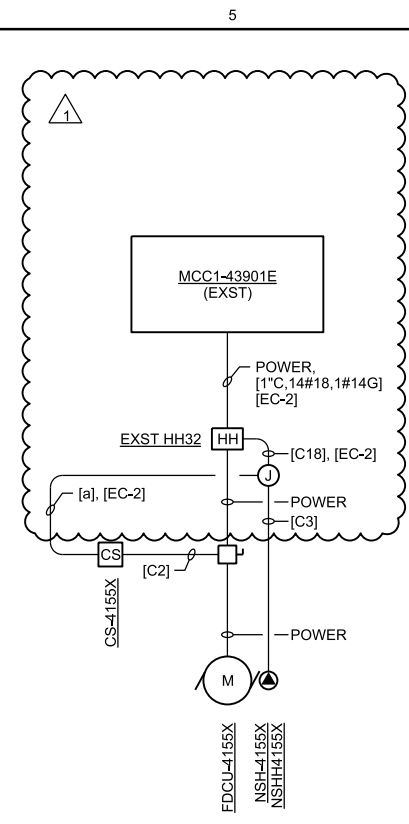

CBD-16: SECONDARY CLARIFIER DRIVE
NTS X=1,2

CONDUIT CALLOUTS
(THIS DWG ONLY)

[a]	=	1" C, 15#14, 1#14G
[b]	=	1" C, 2#12, 1#12G
[c]	=	1" C, 16#14, 1#14G
[d]	=	4/2" C, EMPTY
[e]	=	1 1/2" C, 3#10, 1#6G

NO.	DATE	REVISION	CHK	APVD	M. GROSS
2	12/22/16	ADDENDUM NO. 3			
1	12/16/16	ADDENDUM NO. 2			

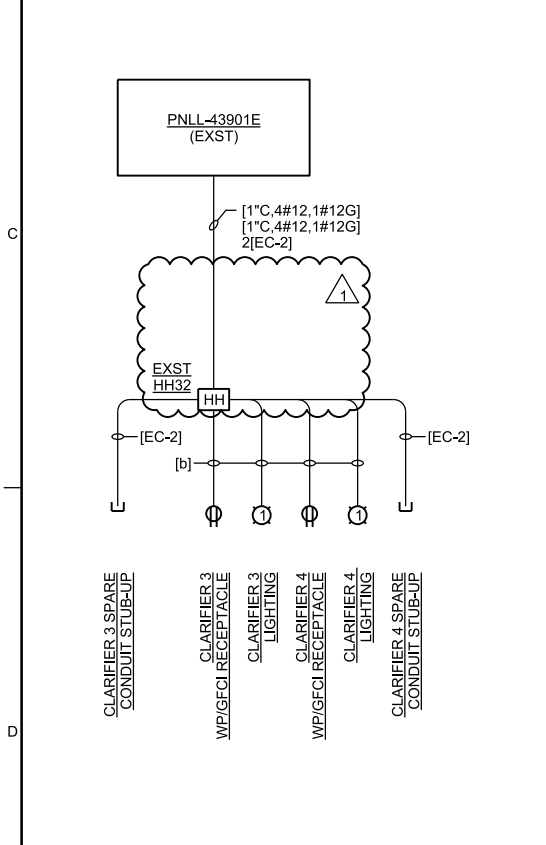

CBD-17: SECONDARY CLARIFIER DRIVE - FACILITY
NTS

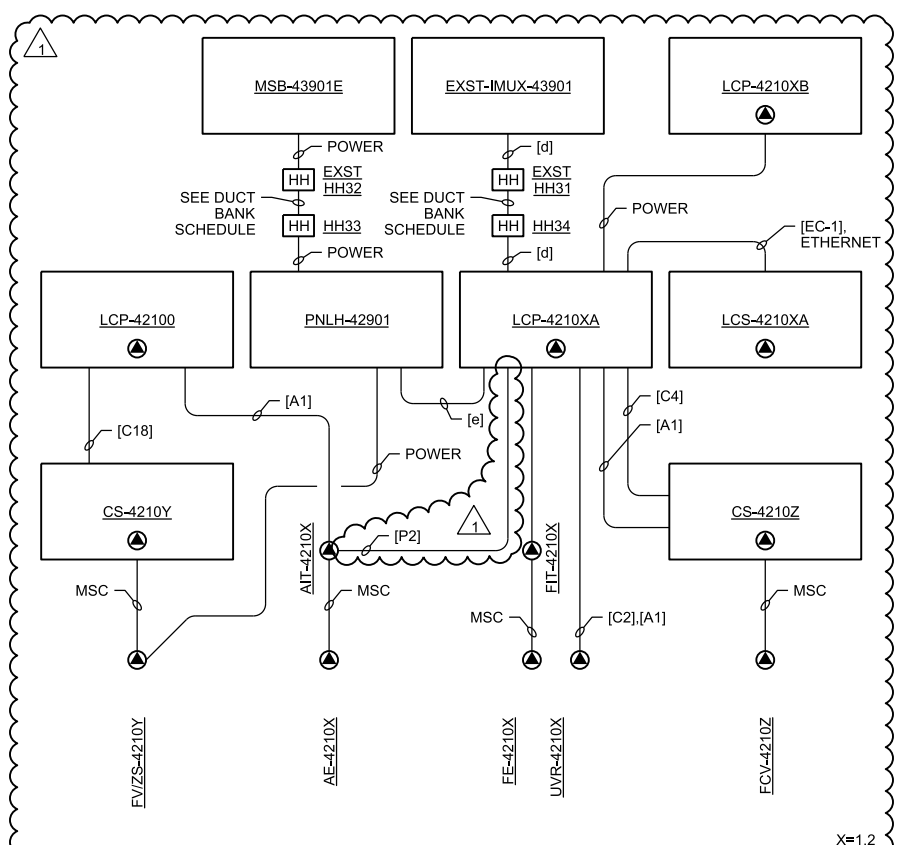

CBD-18: UV REACTORS
NTS

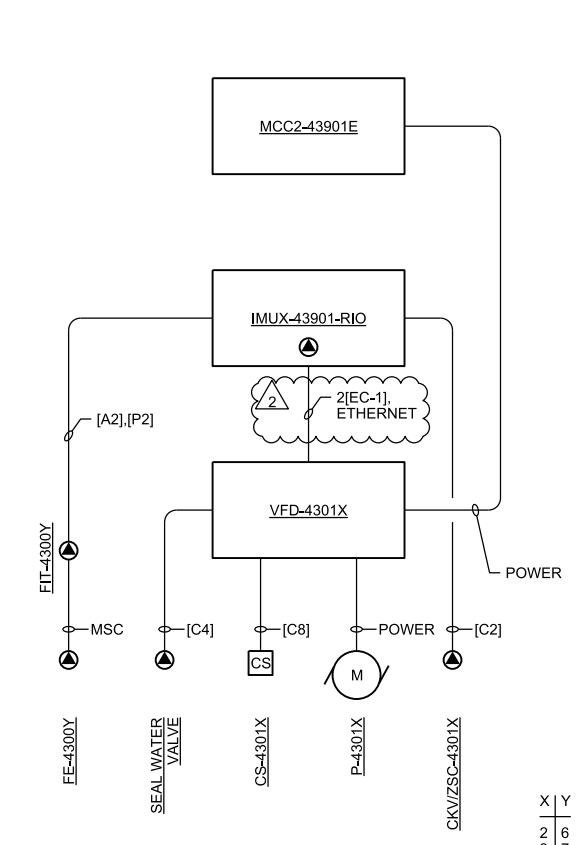

CBD-19: NEW RAS PUMPS
NTS

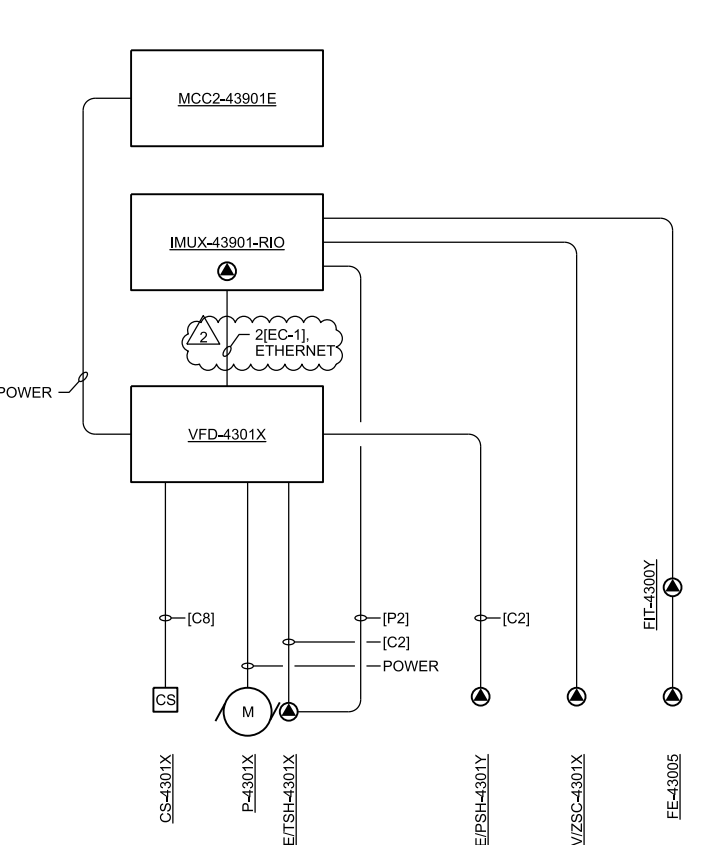

CBD-20: WAS/RDT PUMPS
NTS

ch2m
SITE ELECTRICAL
CABLE BLOCK DIAGRAMS 3

PHASE II, 6 MGD EXPANSION
FOUR MILE CREEK WORTH
DEPARTMENT OF PUBLIC WORKS
CITY OF WICHITA, KANSAS

VERIFY SCALE
BAR IS ONE INCH ON ORIGINAL DRAWING.

DATE	DECEMBER 2016
PROJ	496312
DWG	080-E-6303
SHEET	126 of 314

REUSE OF DOCUMENTS: THIS DOCUMENT, AND THE IDEAS AND DESIGNS INCORPORATED HEREIN, AS AN INSTRUMENT OF PROFESSIONAL SERVICE, IS THE PROPERTY OF CH2M HILL AND IS NOT TO BE USED, IN WHOLE OR IN PART, FOR ANY OTHER PROJECT WITHOUT THE WRITTEN AUTHORIZATION OF CH2M HILL.

© CH2M HILL 2016. ALL RIGHTS RESERVED.

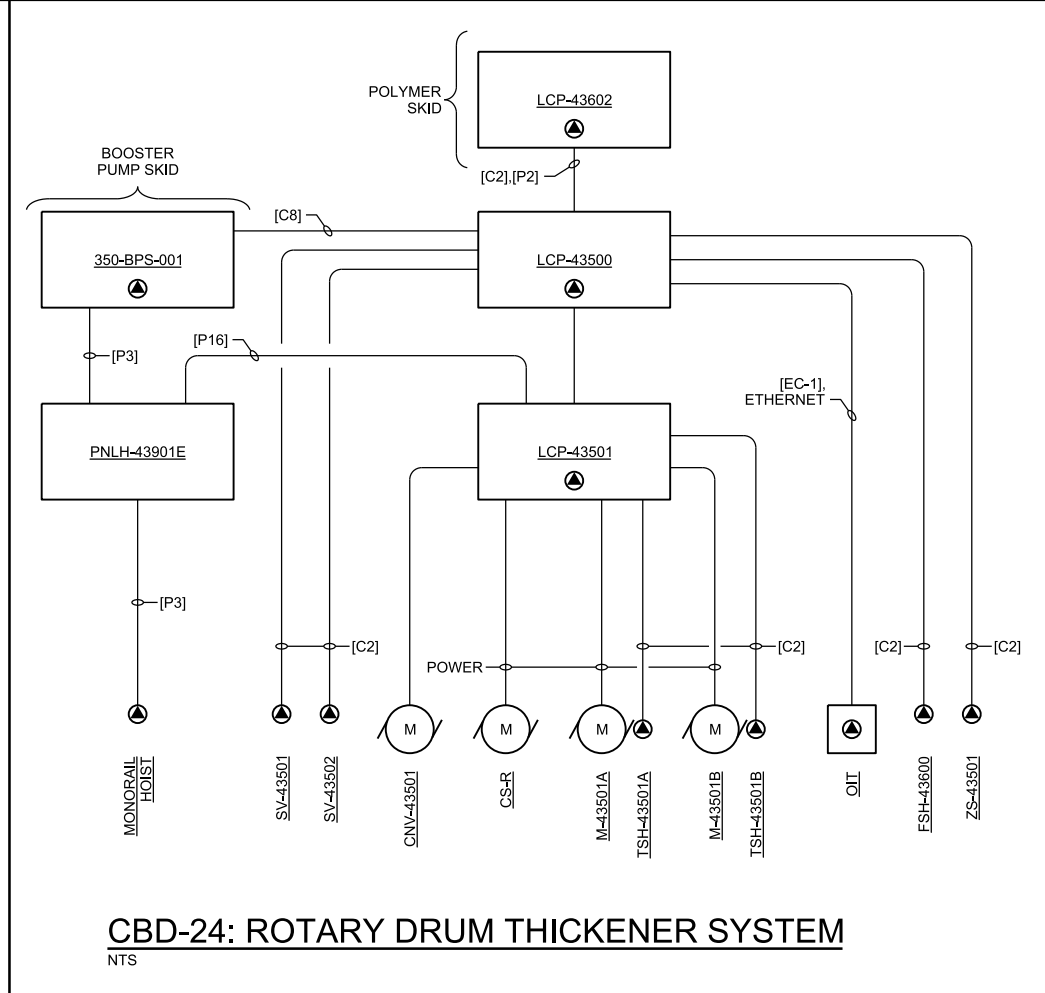
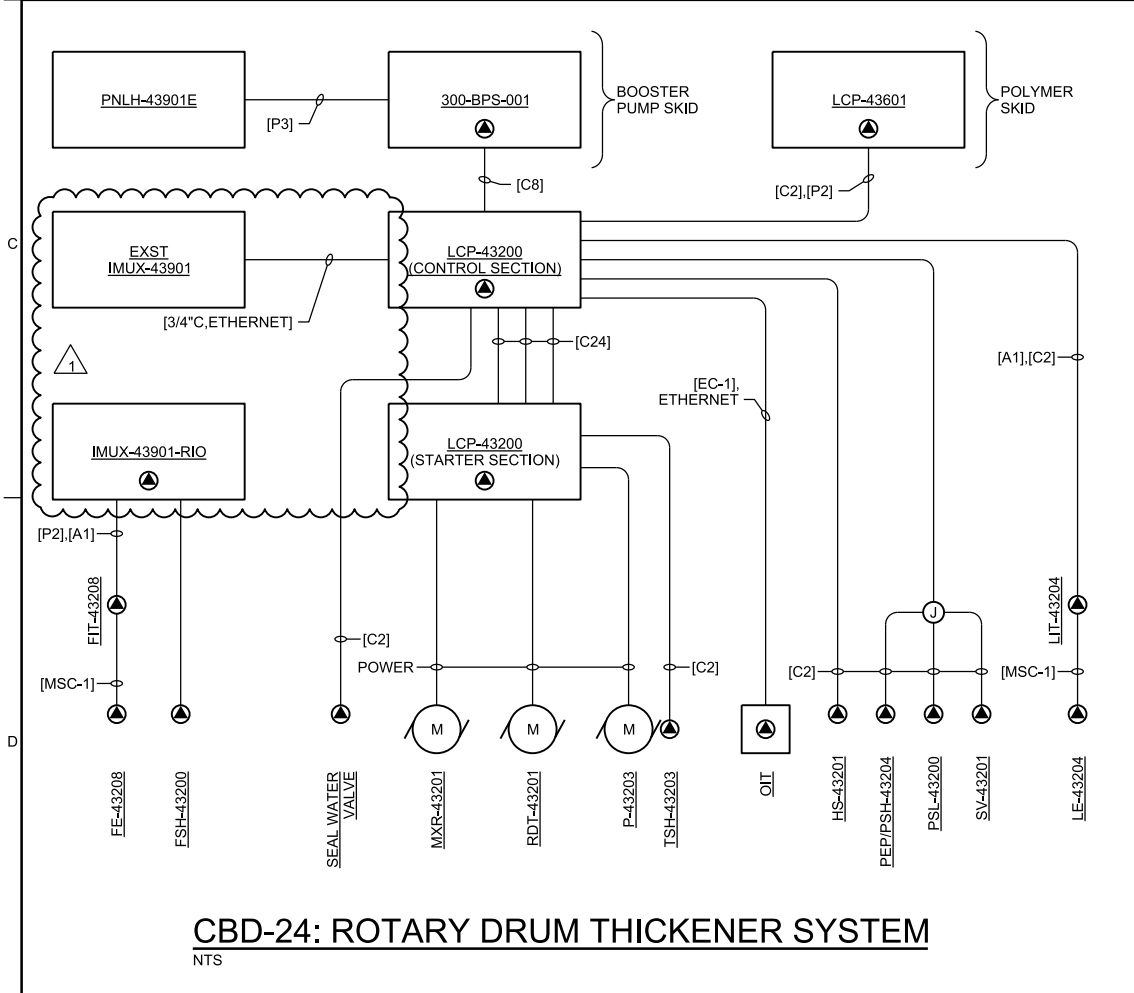
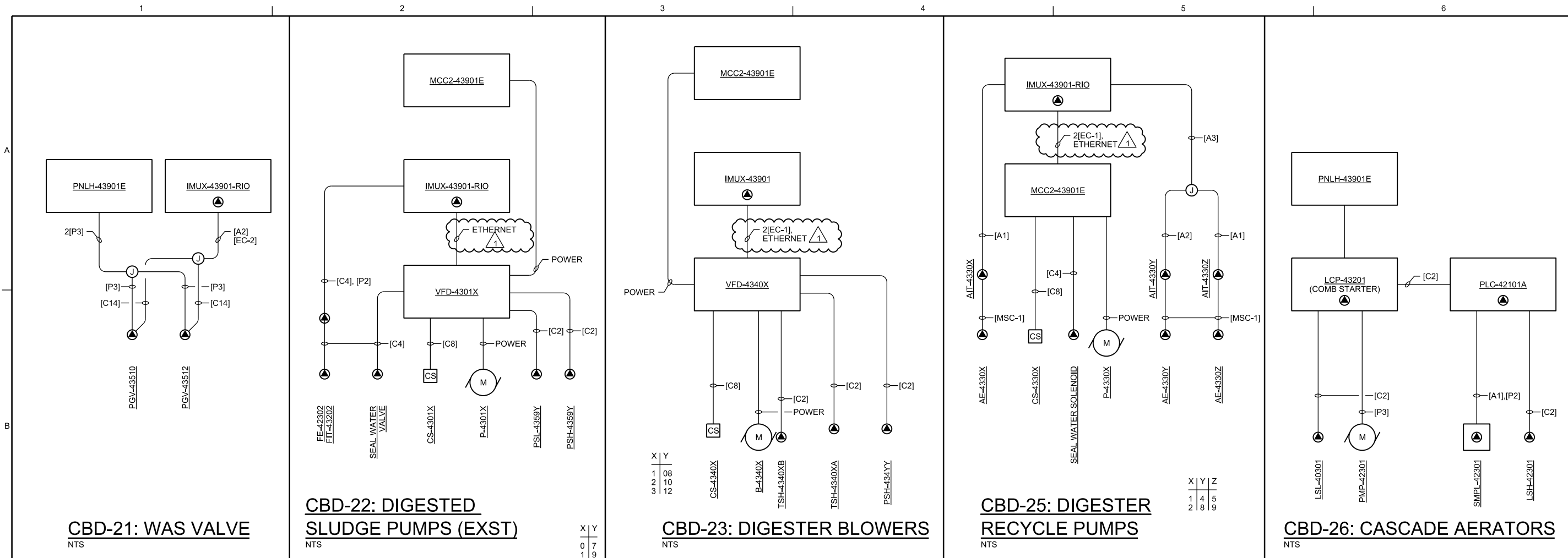

NO.	1	DATE	12/23/16	ADDENDUM NO.	3	REVISION	CHK	APVD	M. GROSS
DSGN	J. LANDMAN	DR	A. CUGLIATI	CHK	APVD	M. GROSS	BY	APVD	M. GROSS
BY	JL	APVD	IMG						

PHASE II, 6 MGD EXPANSION
FOUR MILE CREEK WQRF
DEPARTMENT OF PUBLIC WORKS
CITY OF WICHITA, KANSAS

ch2m
SITE ELECTRICAL

CABLE BLOCK DIAGRAMS 4

VERIFY SCALE
BAR IS ONE INCH ON ORIGINAL DRAWING.

DATE: DECEMBER 2016
PROJ: 496312
DWG: 080-E-6304
SHEET: 127 of 314

BIDDING SET

GENERAL NOTES

1. MOUNT MAN DOWN PANEL IN ACCESSIBLE AREA.
2. CLASS 1 DIV 1 AREA.
3. INTRINSICALLY SAFE RELAY.
4. ALL I/O WIRES TO IMPUX-41902-RIO.
5. PROVIDED BY PUMP VENDOR AS PER SPEC 44 42 56 04.
6. MODBUS TCP/IP OVER ETHERNET.

THIS DOCUMENT IS AN ELECTRONIC COPY. ORIGINAL DOCUMENT WAS ISSUED AND SEALED ON 11/04/2016. THE ORIGINAL DOCUMENT IS STORED AT THE OFFICES OF CH2M HILL ENGINEERS, INC., ENGLEWOOD, CO.

NO.	DATE	BY	APPROVED
1	22 12 16	ADDENDUM NO. 3	
REVISION		CHK	APVD
DR		E KRISTEL	L FOX
DSGN		J PITTS	E JOHNSON

PHASE II, 6 MGD EXPANSION
FOUR MILE CREEK WORK
DEPARTMENT OF PUBLIC WORKS
CITY OF WICHITA, KANSAS

INSTRUMENTATION AND CONTROLS
INFLUENT PUMPING P&ID

VERIFY SCALE	BAR IS ONE INCH ON ORIGINAL DRAWING.
DATE	NOVEMBER 2016
PROJ	496312
DWG	090-N-0002
SHEET	131 of 314

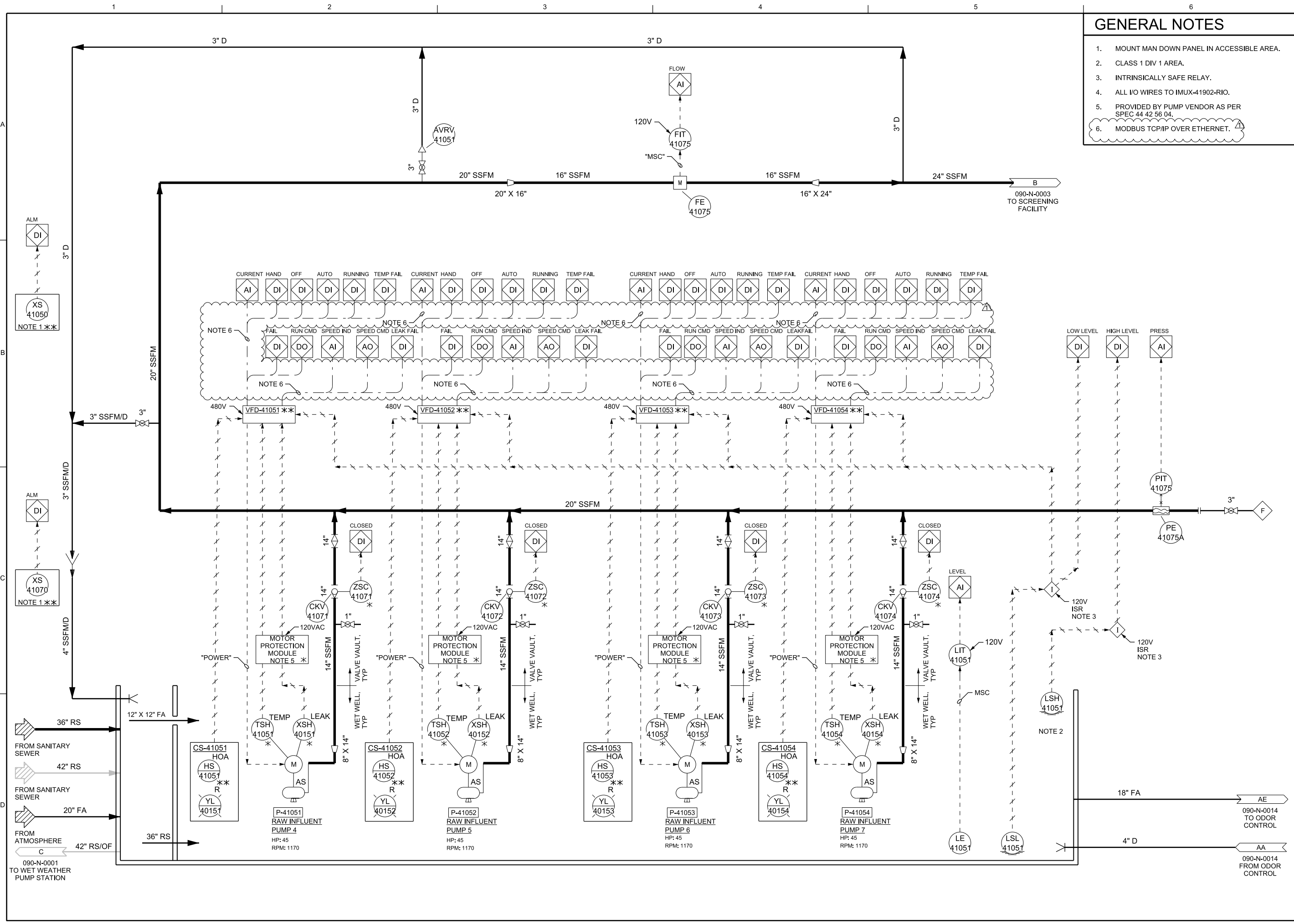

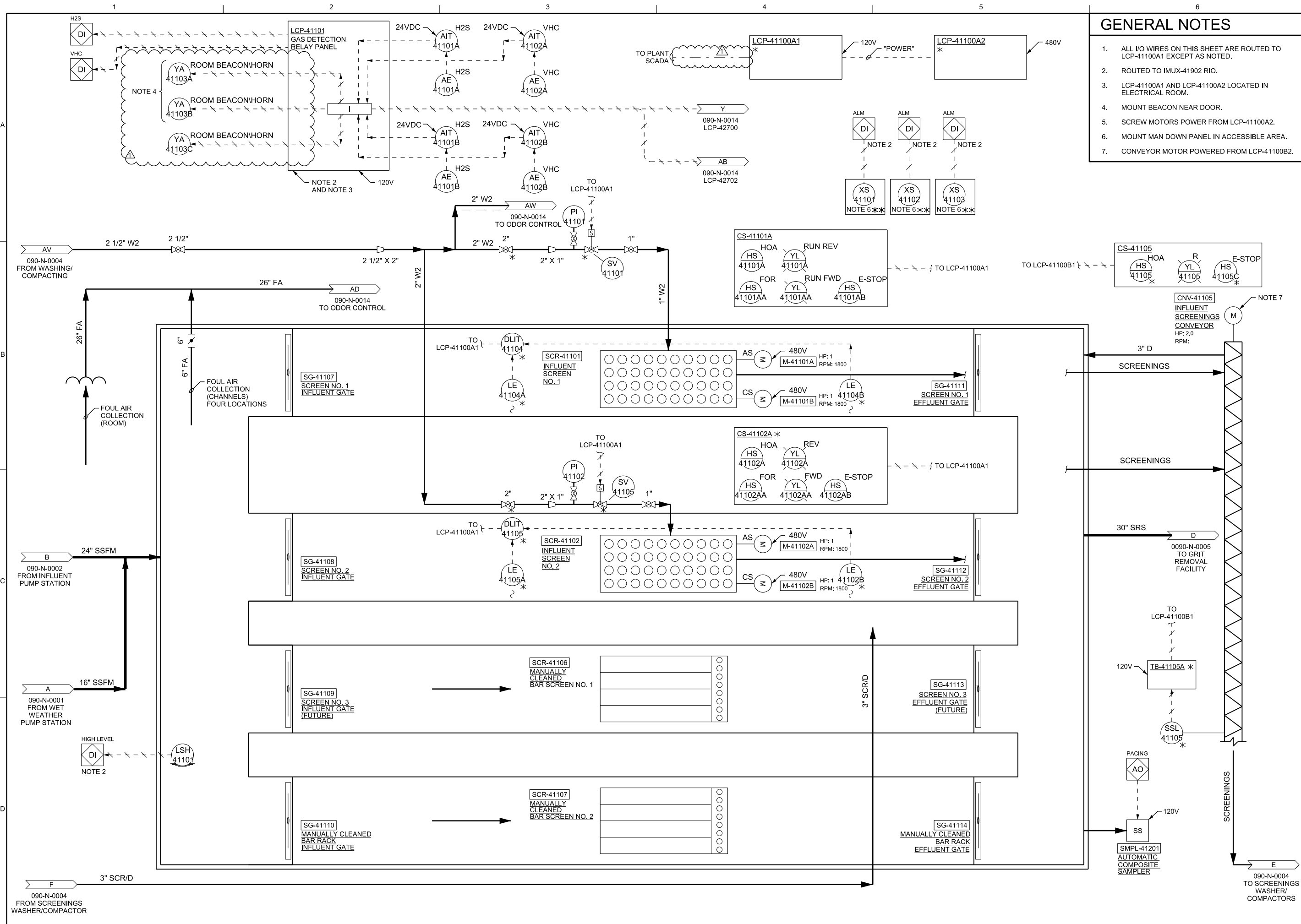

- ### GENERAL NOTES
- ALL I/O WIRES ON THIS SHEET ARE ROUTED TO LCP-41100A1 EXCEPT AS NOTED.
 - ROUTED TO IMUX-41902 RIO.
 - LCP-41100A1 AND LCP-41100A2 LOCATED IN ELECTRICAL ROOM.
 - MOUNT BEACON NEAR DOOR.
 - SCREW MOTORS POWER FROM LCP-41100A2.
 - MOUNT MAN DOWN PANEL IN ACCESSIBLE AREA.
 - CONVEYOR MOTOR POWERED FROM LCP-41100B2.

THIS DOCUMENT IS AN ELECTRONIC COPY OF THE ORIGINAL DOCUMENT. THE ORIGINAL DOCUMENT IS STORED AT THE OFFICES OF CH2M HILL ENGINEERS, INC., ENGLEWOOD, CO.

NO.	DATE	REVISION	BY	APVD
1	22 12 16	ADDENDUM NO. 3	J RYSALVY	E JOHNSON
			DR	APVD
			CHK	APVD
			DESIGN	APVD

PHASE II, 6 MGD EXPANSION
FOUR MILE CREEK WORTH
DEPARTMENT OF PUBLIC WORKS
CITY OF WICHITA, KANSAS

INSTRUMENTATION AND CONTROLS
SCREENING FACILITY
INFLUENT SCREENS P&ID

VERIFY SCALE	BAR IS ONE INCH ON ORIGINAL DRAWING.
DATE	NOVEMBER 2016
PROJ	496312
DWG	090-N-0003
SHEET	132 of 314

REUSE OF DOCUMENTS: THIS DOCUMENT, AND THE IDEAS AND DESIGNS INCORPORATED HEREIN, AS AN INSTRUMENT OF PROFESSIONAL SERVICE, IS THE PROPERTY OF CH2M HILL AND IS NOT TO BE USED, IN WHOLE OR IN PART, FOR ANY OTHER PROJECT WITHOUT THE WRITTEN AUTHORIZATION OF CH2M HILL.

GENERAL NOTES

- ALL I/O WIRES ON THIS SHEET ARE ROUTED TO LCP-4110B1 EXCEPT AS NOTED.
- WIRED TO IMUX-41902-RI0.
- MOTORS POWERED FROM LCP-41100B2.

THIS DOCUMENT IS AN ELECTRONIC COPY. ORIGINAL DOCUMENT WAS ISSUED AND SEALED ON 11/04/2016. THE ORIGINAL DOCUMENT IS STORED AT THE OFFICES OF CH2M HILL ENGINEERS, INC., ENGLEWOOD, CO.

NO.	DATE	REVISION	BY	APVD
1	22 12 16	ADDENDUM NO. 3	J. RYSALY	E. JOHNSON
DR		CHK	L. FOX	

PHASE II, 6 MGD EXPANSION
FOUR MILE CREEK WOLF
DEPARTMENT OF PUBLIC WORKS
CITY OF WICHITA, KANSAS

INSTRUMENTATION AND CONTROLS
SCREENING FACILITY
WASHING/COMPACTING P&ID

DATE	NOVEMBER 2016
PROJ	496312
DWG	090-N-0004
SHEET	133 of 314

BIDDING SET

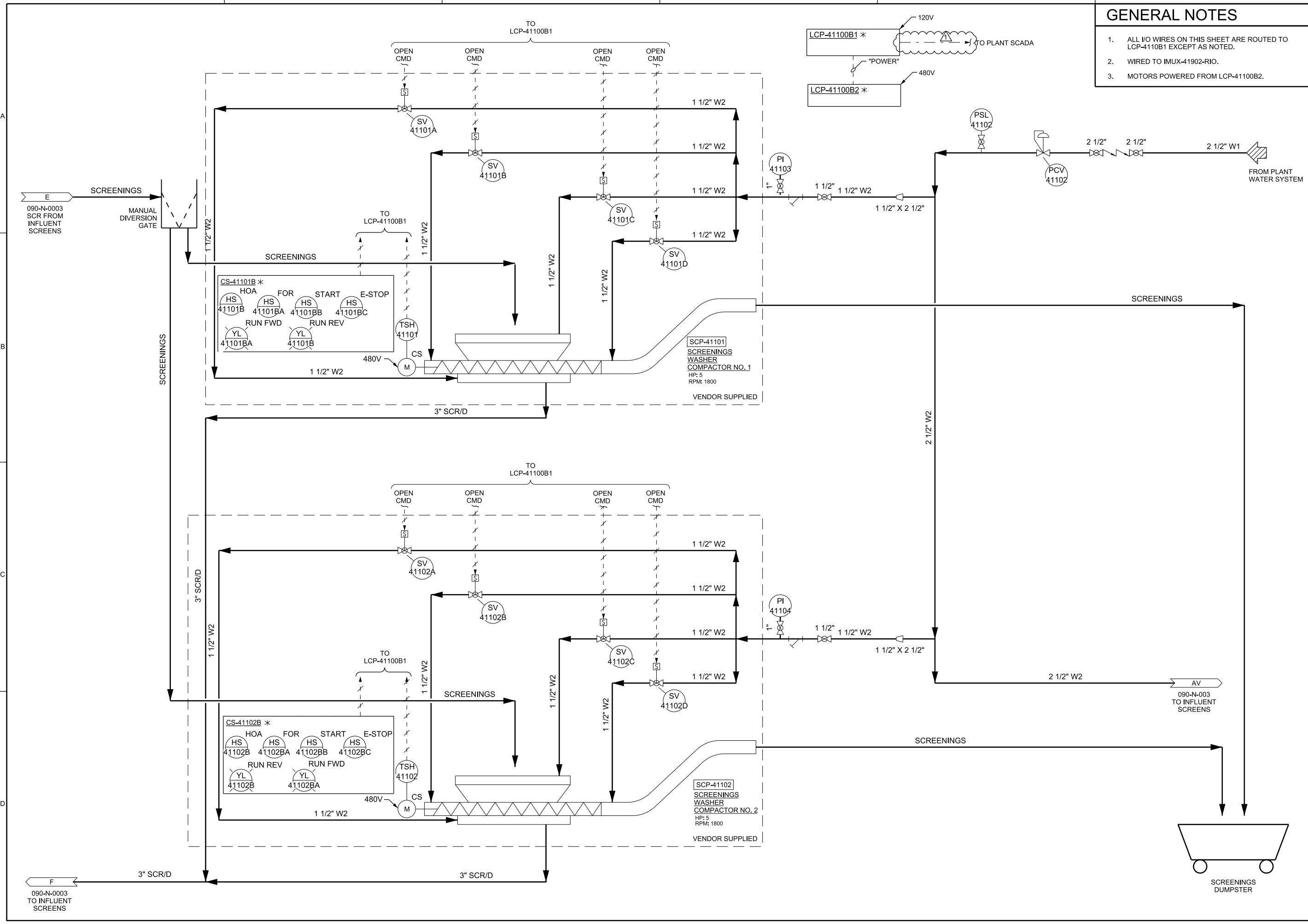

GENERAL NOTES

1. MODBUS TCP/IP TO IMUX-41902-RIO.

THIS DOCUMENT IS AN ELECTRONIC COPY. ORIGINAL DOCUMENT WAS ISSUED AND SEALED ON 11/04/2016. THE ORIGINAL DOCUMENT IS STORED AT THE OFFICES OF CH2M HILL ENGINEERS, INC., ENGLEWOOD, CO.

NO.	DATE	REVISION	CHK	APVD
1	22 12 16	ADDENDUM NO. 3	J RYSAVY	L FOX
DSGN			DR	APVD
NO.			CHK	APVD
ADDENDUM NO. 3			BY	DT
			BY	DT

PHASE II, 6 MGD EXPANSION
FOUR MILE CREEK WOLF
DEPARTMENT OF PUBLIC WORKS
CITY OF WICHITA, KANSAS

INSTRUMENTATION AND CONTROLS
GRIT HANDLING P&ID

VERIFY SCALE	BAR IS ONE INCH ON ORIGINAL DRAWING.
DATE	NOVEMBER 2016
PROJ	496312
DWG	090-N-0006
SHEET	135 of 314

BIDDING SET

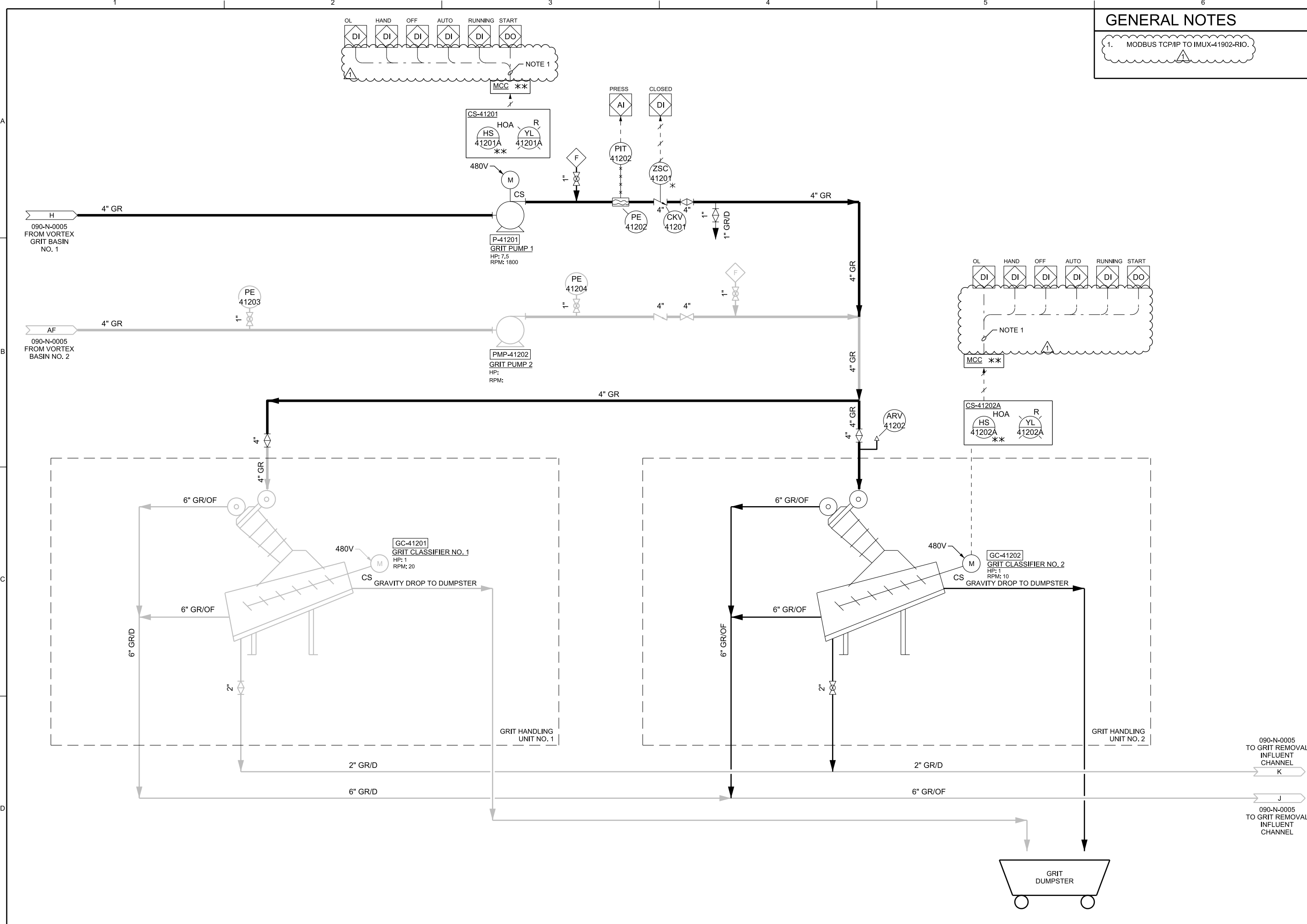

GENERAL NOTES

- VENDOR SUPPLIED THERMOSTAT.
- ALL I/O WIRES TO IMUX 43901-RIO.
- INTRINSICALLY SAFE RELAY.
- 1.MODBUS TCP/IP TO IMUX-41902-RIO

THIS DOCUMENT IS AN ELECTRONIC COPY ORIGINAL DOCUMENT WAS ISSUED AND SEALED ON 11/04/2016. THE ORIGINAL DOCUMENT IS STORED AT THE OFFICES OF CH2M HILL ENGINEERS, INC., ENGLEWOOD, CO.

NO.	DATE	BY	APVD
1	22 12 16	ADDENDUM NO. 3	
DR	DESIGN	REVISION	CHK
S. LEVESQUE	E. KRISTEL	L. FOX	E. JOHNSON

PHASE II, 6 MGD EXPANSION
FOUR MILE CREEK WOLF
DEPARTMENT OF PUBLIC WORKS
CITY OF WICHITA, KANSAS

INSTRUMENTATION AND CONTROLS
BIOREACTOR P&ID

VERIFY SCALE	DATE	NOVEMBER 2016
BAR IS ONE INCH ON ORIGINAL DRAWING.	PROJ	496312
	DWG	090-N-0008
	SHEET	137 of 314

BIDDING SET

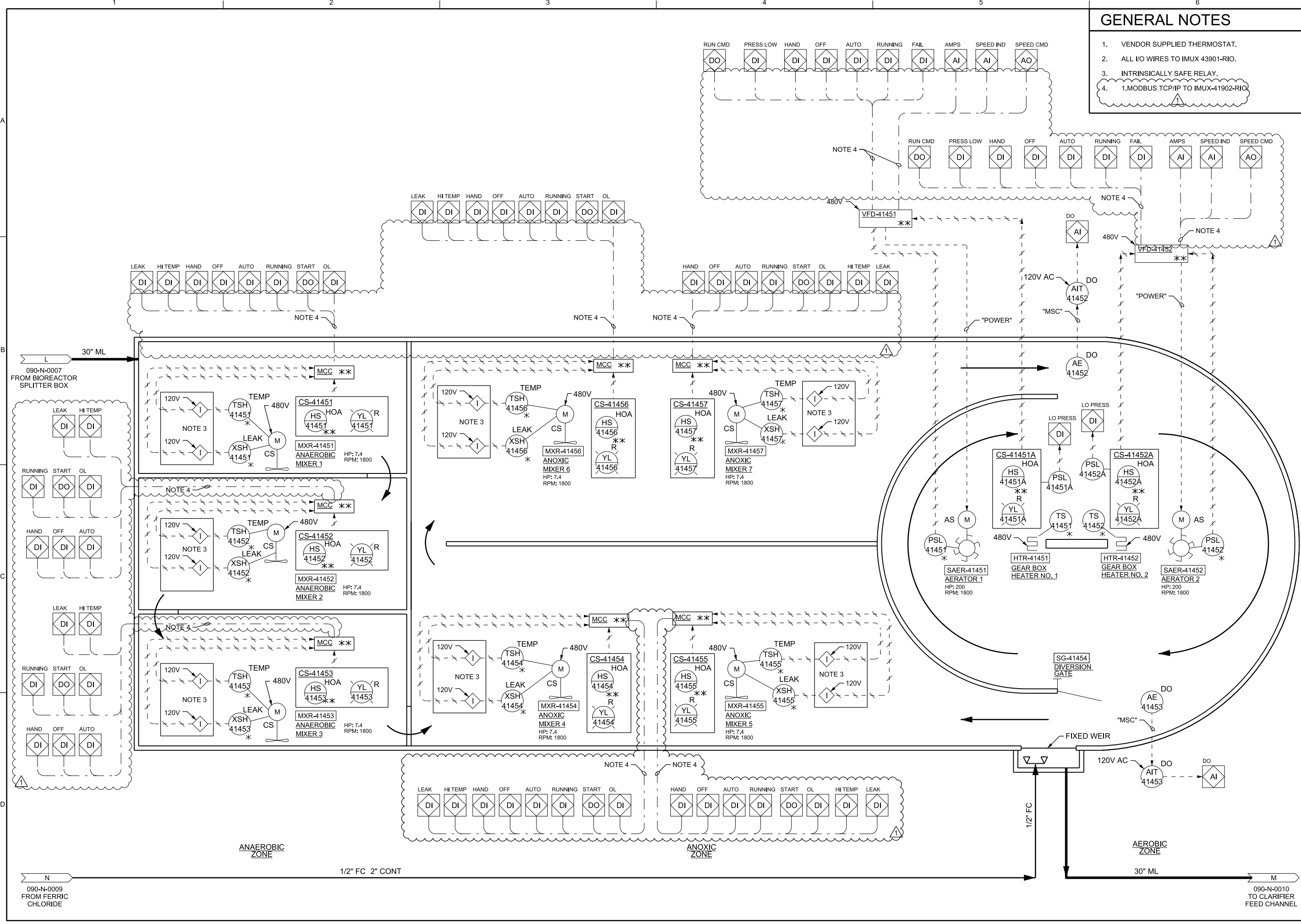

GENERAL NOTES

1. I/O WIRES TO IMUX-43901-RIO, OVER MODBUS TCP/IP.

THIS DOCUMENT IS AN ELECTRONIC COPY. ORIGINAL DOCUMENT WAS ISSUED AND SEALED ON 11/04/2016. THE ORIGINAL DOCUMENT IS STORED AT THE OFFICES OF CH2M HILL ENGINEERS, INC., ENGLEWOOD, CO.

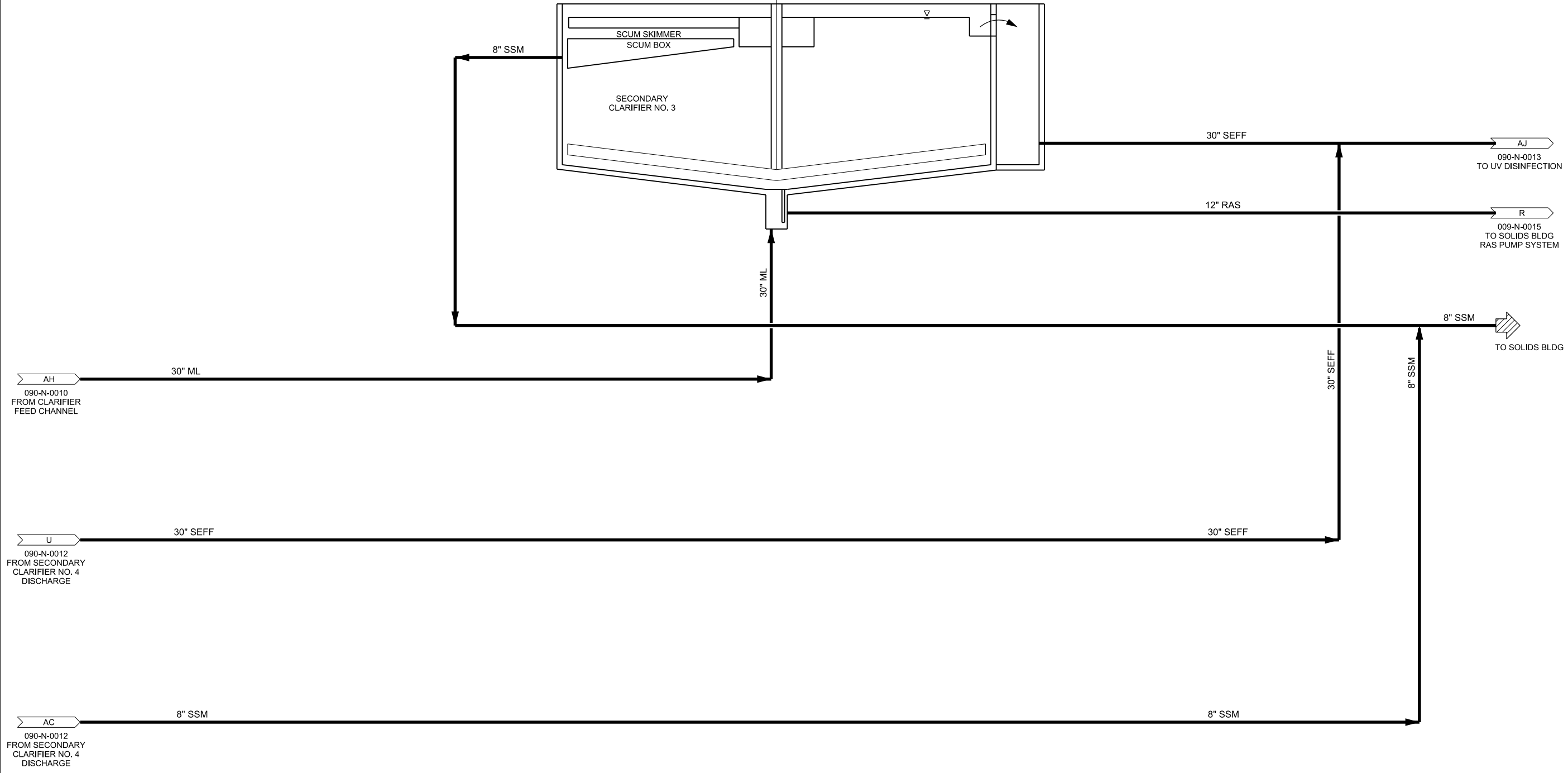
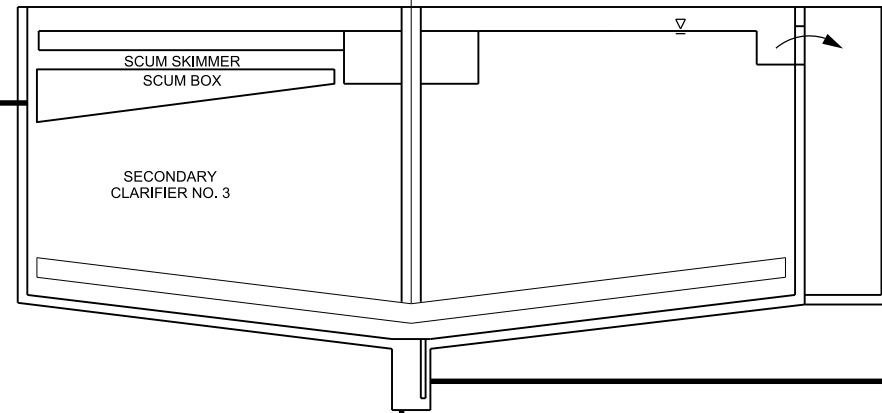
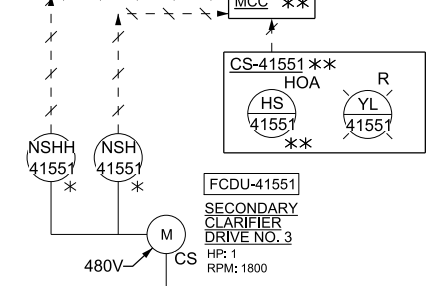
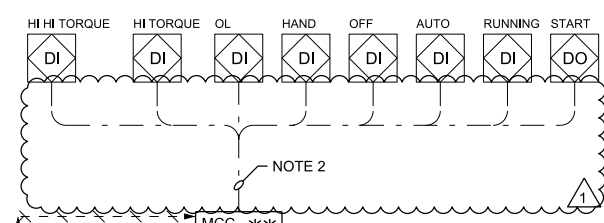

NO.	DATE	REVISION	BY	APVD
1	22 12 16	ADDENDUM NO. 3	SF	DT
DR		CHK		
DSGN				
S. RICHARDSON				
L. FOX				
E. JOHNSON				

PHASE II, 6 MGD EXPANSION
FOUR MILE CREEK WQRF
DEPARTMENT OF PUBLIC WORKS
CITY OF WICHITA, KANSAS

INSTRUMENTATION AND CONTROLS
SECONDARY CLARIFIER NO. 3 P&ID

VERIFY SCALE	BAR IS ONE INCH ON ORIGINAL DRAWING.
DATE	NOVEMBER 2016
PROJ	496312
DWG	090-N-0011
SHEET	140 of 314

BIDDING SET

GENERAL NOTES

1. I/O WIRES TO IMUX-43901-RIO, OVER MODBUS TCP/IP

THIS DOCUMENT IS AN ELECTRONIC COPY. ORIGINAL DOCUMENT WAS ISSUED AND SEALED ON 11/04/2016. THE ORIGINAL DOCUMENT IS STORED AT THE OFFICES OF CH2M HILL ENGINEERS, INC., ENGLEWOOD, CO.

11/04/2016
E. JOHNSON
BY APVD
SF

L. FOX
APVD

REVISION
CHK

DR
S. RICHARDSON

NO. DATE
1 22 12 16

ADDENDUM NO. 3

PHASE II, 6 MGD EXPANSION
FOUR MILE CREEK WOLF
DEPARTMENT OF PUBLIC WORKS
CITY OF WICHITA, KANSAS

INSTRUMENTATION AND CONTROLS
SECONDARY CLARIFIER NO. 4 P&ID

VERIFY SCALE
BAR IS ONE INCH ON ORIGINAL DRAWING.

DATE NOVEMBER 2016
PROJ 496312
DWG 090-N-0012
SHEET 141 of 314

REUSE OF DOCUMENTS: THIS DOCUMENT, AND THE IDEAS AND DESIGNS INCORPORATED HEREIN, AS AN INSTRUMENT OF PROFESSIONAL SERVICE, IS THE PROPERTY OF CH2M HILL AND IS NOT TO BE USED, IN WHOLE OR IN PART, FOR ANY OTHER PROJECT WITHOUT THE WRITTEN AUTHORIZATION OF CH2M HILL.

PHASE II, 6 MGD EXPANSION
FOUR MILE CREEK WOLF
DEPARTMENT OF PUBLIC WORKS
CITY OF WICHITA, KANSAS

INSTRUMENTATION AND CONTROLS
SECONDARY CLARIFIER NO. 4 P&ID

VERIFY SCALE
BAR IS ONE INCH ON ORIGINAL DRAWING.

DATE NOVEMBER 2016
PROJ 496312
DWG 090-N-0012
SHEET 141 of 314

REUSE OF DOCUMENTS: THIS DOCUMENT, AND THE IDEAS AND DESIGNS INCORPORATED HEREIN, AS AN INSTRUMENT OF PROFESSIONAL SERVICE, IS THE PROPERTY OF CH2M HILL AND IS NOT TO BE USED, IN WHOLE OR IN PART, FOR ANY OTHER PROJECT WITHOUT THE WRITTEN AUTHORIZATION OF CH2M HILL.

PHASE II, 6 MGD EXPANSION
FOUR MILE CREEK WOLF
DEPARTMENT OF PUBLIC WORKS
CITY OF WICHITA, KANSAS

INSTRUMENTATION AND CONTROLS
SECONDARY CLARIFIER NO. 4 P&ID

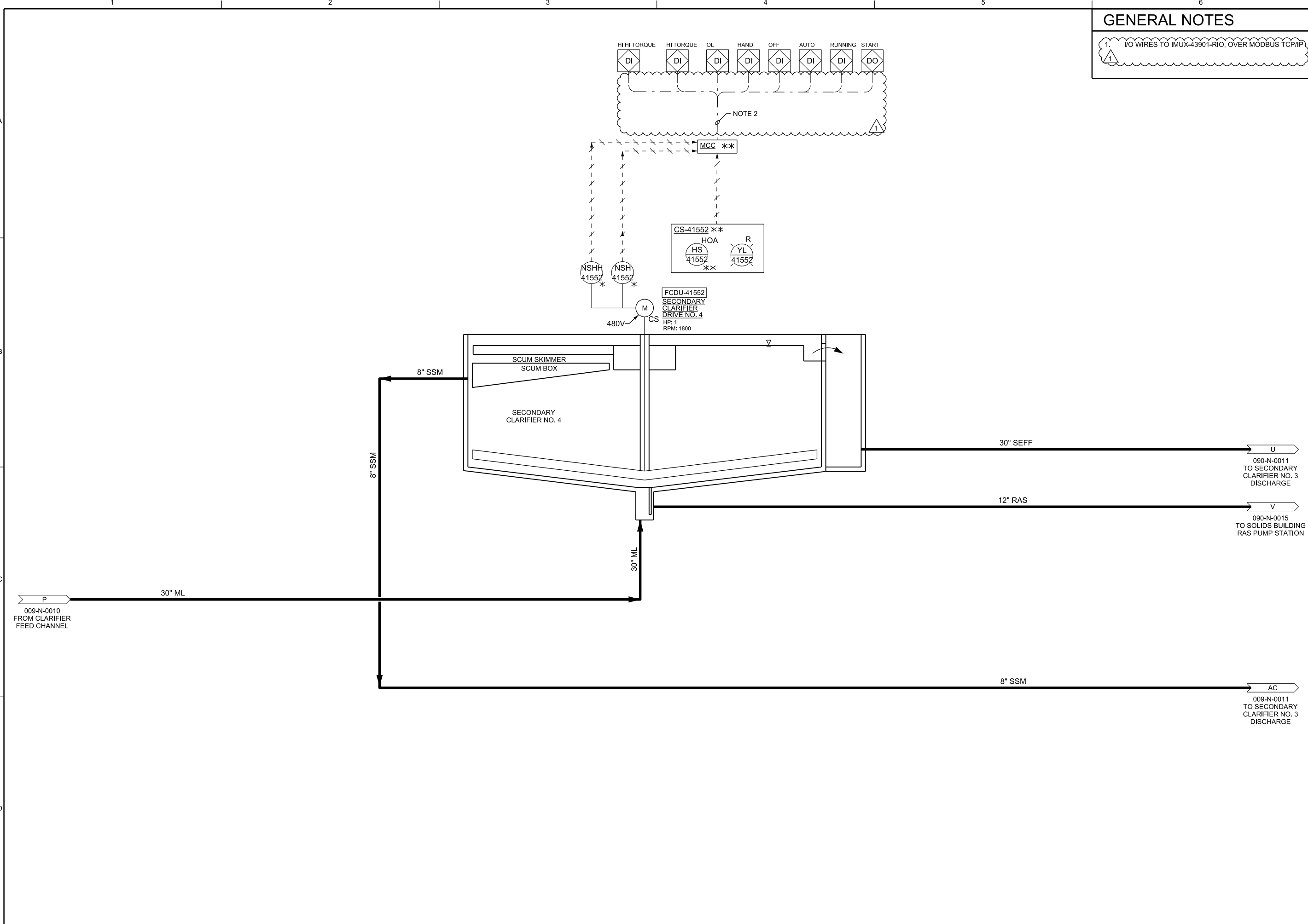

BIDDING SET

GENERAL NOTES

1. PROCESS UNIT / FACILITY IS DISINFECTION FACILITY (DIS). FACILITY NUMBER IS 210.
2. REFERENCE SECTION 44 44 73 UV DISINFECTION SYSTEM FOR ADDITIONAL INFORMATION ON IO SIGNALS, COMMUNICATIONS AND DATA MESSAGING.
3. PROVIDE INSTRUMENTS AND INTRINSIC SAFETY CONTROLS AND WIRING, APPROVED AND ARRANGED, FOR USE IN CLASS 1 DIVISION 1 AND DIVISION 2 LOCATIONS AS IDENTIFIED ON ELECTRICAL AREA CLASSIFICATION DRAWINGS AND NATIONAL ELECTRICAL CODE (NEC) ARTICLE 501 CLASS 1 LOCATIONS AND 504 INTRINSICALLY SAFE SYSTEMS.
4. * DENOTES SCOPE OF UV EQUIPMENT SUPPLIER.
5. LOCAL OPERATOR PANEL BY VENDOR.
6. LOCATE VALVE OPERATOR CONTROL STATION IN ACCESSIBLE AREA.

THIS DOCUMENT IS AN ELECTRONIC COPY. ORIGINAL DOCUMENT WAS ISSUED AND SEALED ON 11/04/2016. THE ORIGINAL DOCUMENT IS STORED AT THE OFFICES OF CH2M HILL ENGINEERS, INC., ENGLEWOOD, CO.

NO.	DATE	REVISION	BY	APVD
1	22 12 16	ADDENDUM NO. 3		

PHASE II, 6 MGD EXPANSION
FOUR MILE CREEK WOLF
DEPARTMENT OF PUBLIC WORKS
CITY OF WICHITA, KANSAS

INSTRUMENTATION AND CONTROLS
UV DISINFECTION P&ID

DATE	NOVEMBER 2016
PROJ	496312
DWG	090-N-0013
SHEET	142 of 314

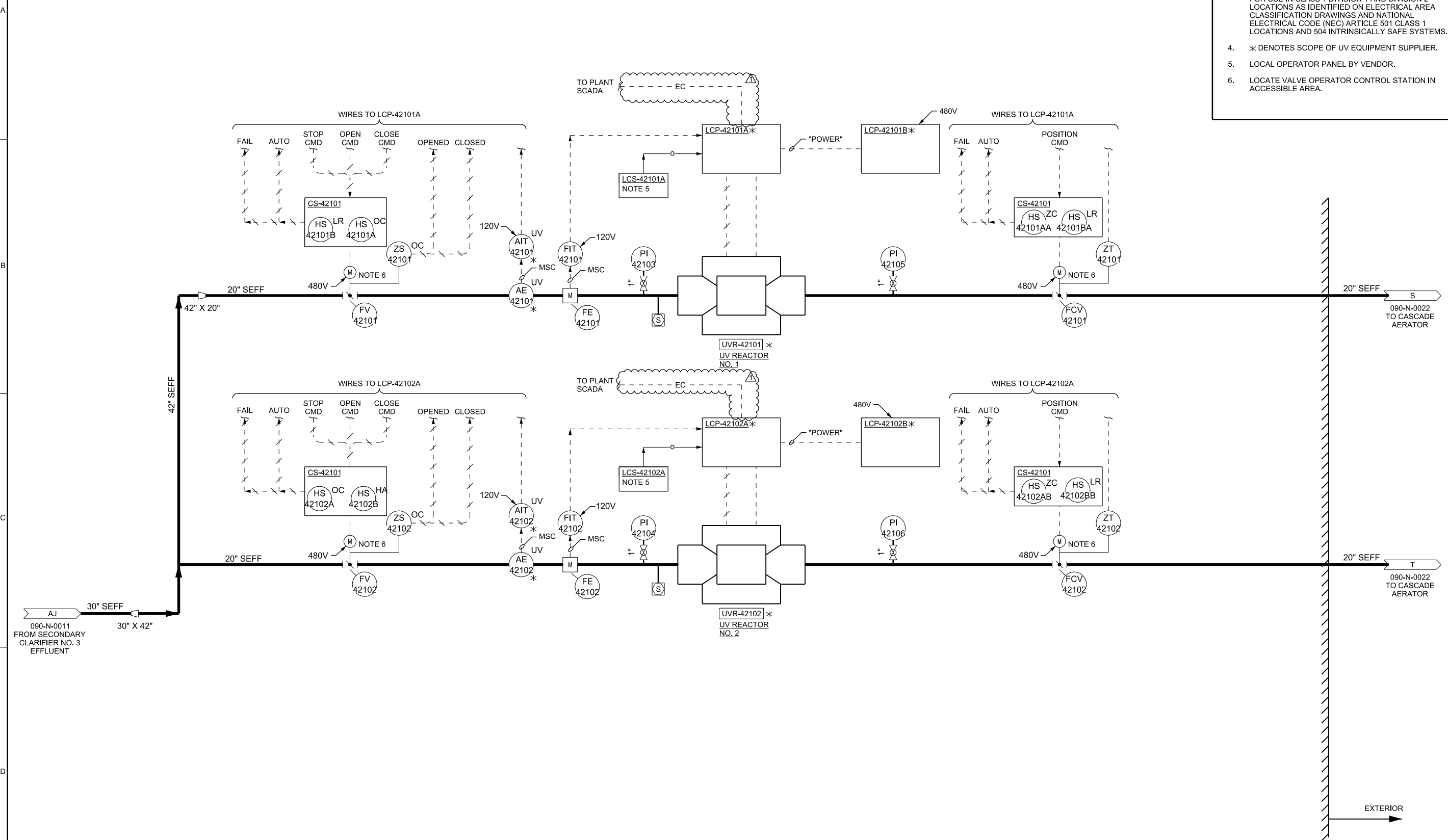

090-N-0011
FROM SECONDARY
CLARIFIER NO. 3
EFFLUENT

EXTERIOR

BIDDING SET

GENERAL NOTES

- * VENDOR SUPPLIED.
- I/O WIRES TO IMUX 43901-RIO.
- REUSE EXISTING CONTROL STATION. RECONNECT TO NEW VFDS.
- MODBUS TCP/IP TO IMUX 43901-RIO.

THIS DOCUMENT IS AN ELECTRONIC COPY ORIGINAL DOCUMENT WAS ISSUED AND SEALED ON 11/04/2016. THE ORIGINAL DOCUMENT IS STORED AT THE OFFICES OF CH2M HILL ENGINEERS, INC., ENGLEWOOD, CO.

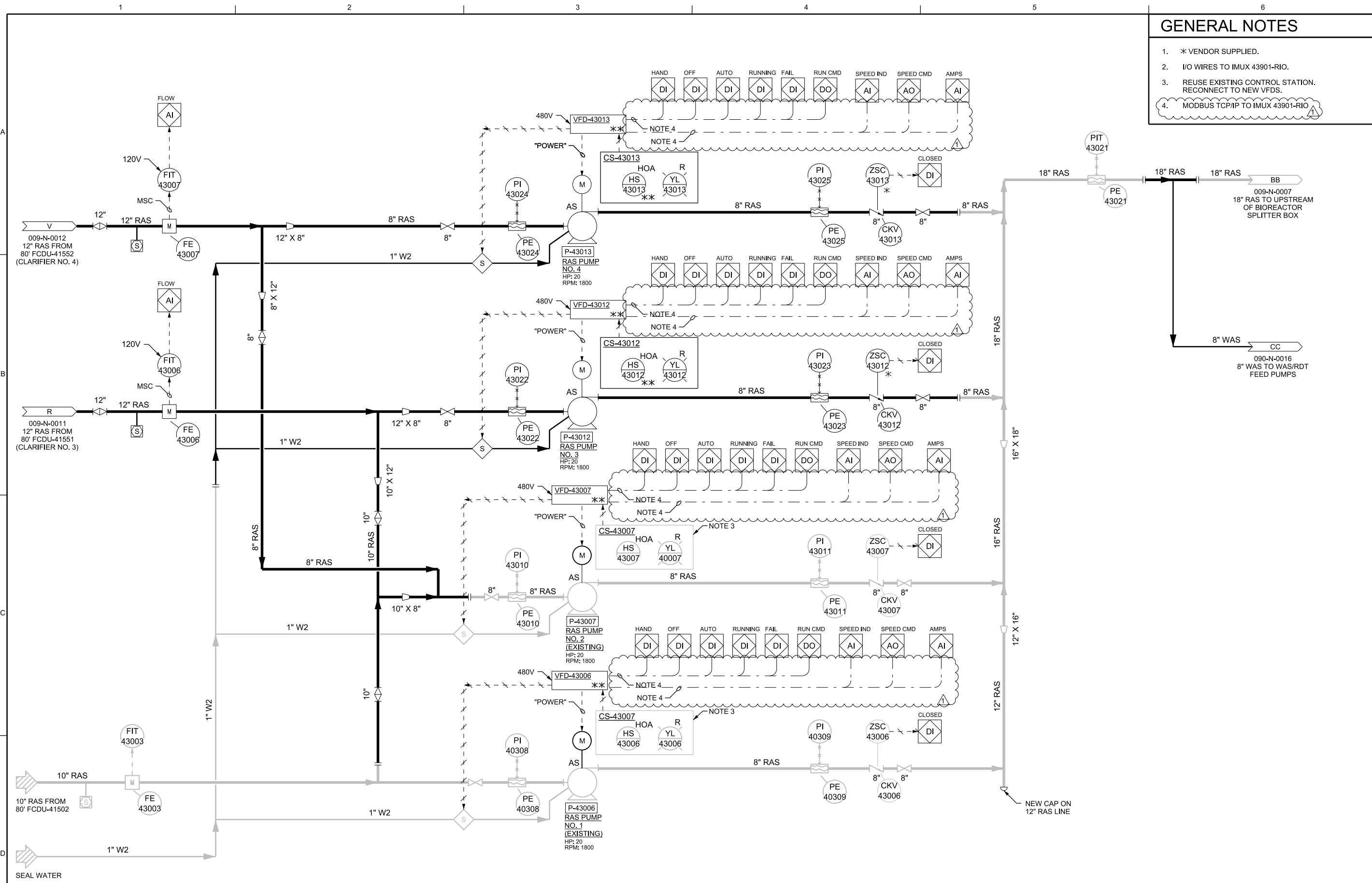

NO.	DATE	REVISION	BY	APVD
1	22 12 16	ADDENDUM NO. 3	E. JOHNSON	L. FOX
		CHK	E. KRISTEL	
		DR	E. JOHNSON	

PHASE II, 6 MGD EXPANSION
 FOUR MILE CREEK WOLF
 DEPARTMENT OF PUBLIC WORKS
 CITY OF WICHITA, KANSAS

INSTRUMENTATION AND CONTROLS
RAS P&ID

VERIFY SCALE	BAR IS ONE INCH ON ORIGINAL DRAWING.
DATE	NOVEMBER 2016
PROJ	496312
DWG	090-N-0015
SHEET	144 of 314

BIDDING SET

GENERAL NOTES

1. LINE IS EXISTING 6" STUB THROUGH WALL.
2. * VENDOR SUPPLIED.
3. LOCATE VALVE OPERATOR CONTROL STATIONS IN ACCESSIBLE AREA.
4. I/O WIRES TO IMUX-43901-RIO.
5. MODBUS TCP/IP TO IMUX 43901-RIO.

THIS DOCUMENT IS AN ELECTRONIC COPY. ORIGINAL DOCUMENT WAS ISSUED AND SEALED ON 11/04/2016. THE ORIGINAL DOCUMENT IS STORED AT THE OFFICES OF CH2M HILL ENGINEERS, INC., ENGLEWOOD, CO.

NO.	DATE	REVISION	CHK	APVD
1	22 12 16	ADDENDUM NO. 3	E. JOHNSON	L. FOX

PHASE II, 6 MGD EXPANSION
FOUR MILE CREEK WOLF
DEPARTMENT OF PUBLIC WORKS
CITY OF WICHITA, KANSAS

INSTRUMENTATION AND CONTROLS WAS AND DIGESTED SLUDGE (DS) PUMPING P&ID

VERIFY SCALE	BAR IS ONE INCH ON ORIGINAL DRAWING.
DATE	NOVEMBER 2016
PROJ	496312
DWG	090-N-0016
SHEET	145 of 314

BIDDING SET

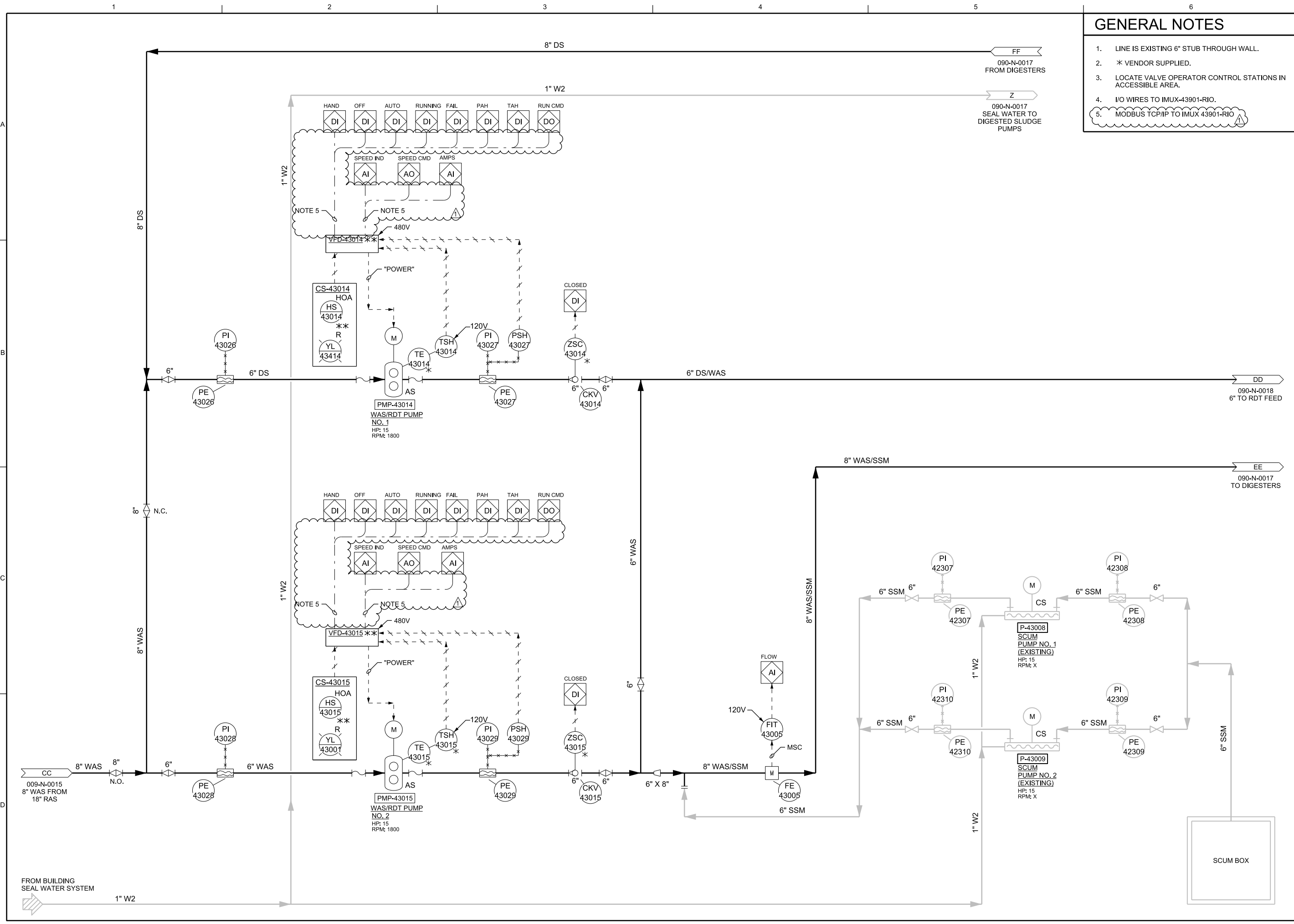

GENERAL NOTES

1. LINE IS EXISTING 6" STUB THROUGH WALL.
2. LOCATE VALVE OPERATOR CONTROL STATIONS IN ACCESSIBLE AREA.
3. I/O WIRES TO IMUX-43901-RI0.
4. MODBUS TCP/IP TO IMUX 43901-RI0.

THIS DOCUMENT IS AN ELECTRONIC COPY. ORIGINAL DOCUMENT WAS ISSUED AND SEALED ON 11/04/2016. THE ORIGINAL DOCUMENT IS STORED AT THE OFFICES OF CH2M HILL ENGINEERS, INC., ENGLEWOOD, CO.

NO.	DATE	REVISION	BY	APVD
1	22 12 16	ADDENDUM NO. 3	SF	DT
DGN			DR	APVD
E. JOHNSON			L. FOX	E. JOHNSON

PHASE II, 6 MGD EXPANSION
FOUR MILE CREEK WOLF
DEPARTMENT OF PUBLIC WORKS
CITY OF WICHITA, KANSAS

**INSTRUMENTATION AND CONTROLS
WAS AND DIGESTED SLUDGE (DS)
PUMPING P&ID**

VERIFY SCALE	
BAR IS ONE INCH ON ORIGINAL DRAWING.	
DATE	NOVEMBER 2016
PROJ	496312
DWG	090-N-0017
SHEET	146 of 314

BIDDING SET

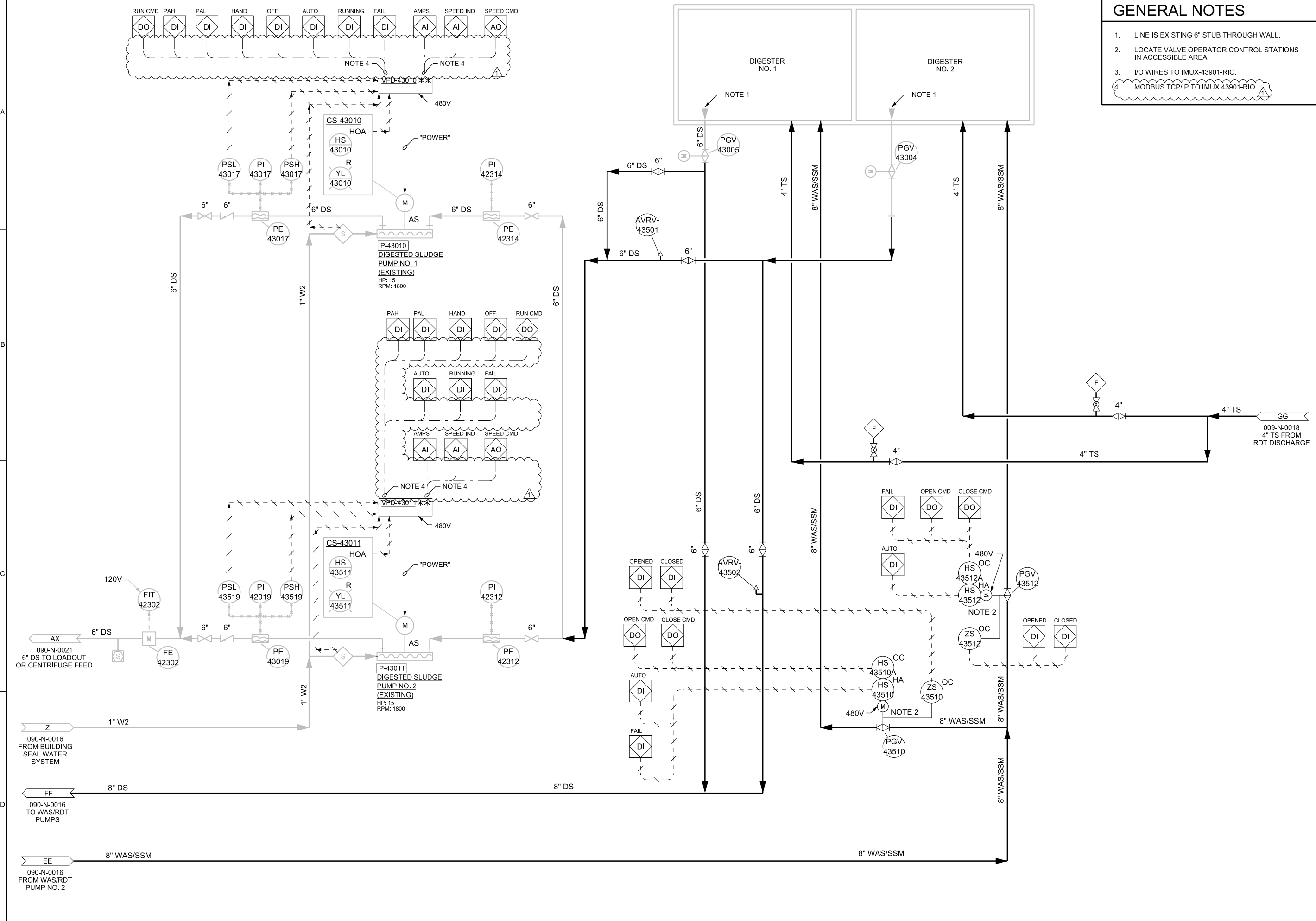

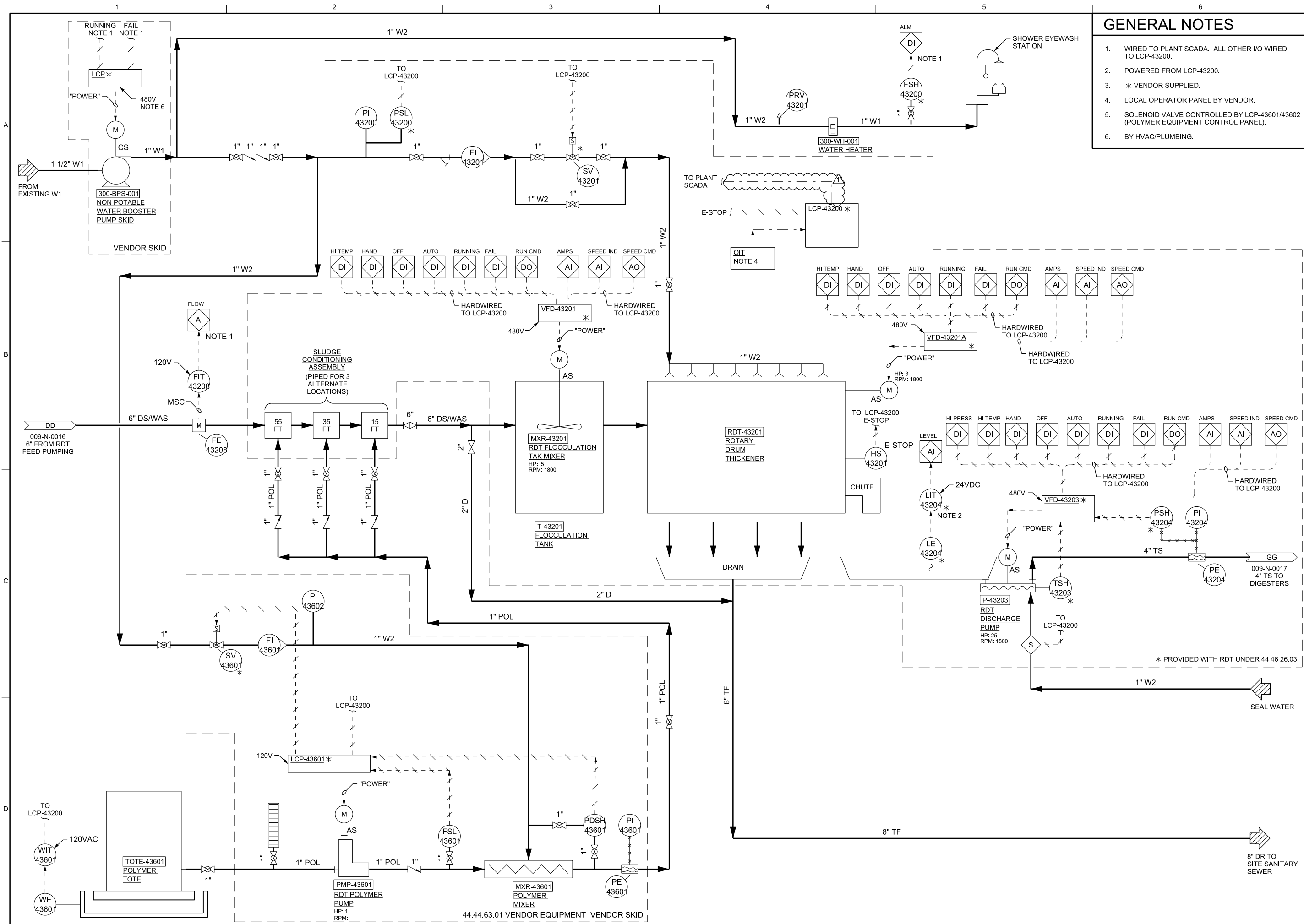

GENERAL NOTES

- WIRED TO PLANT SCADA. ALL OTHER I/O WIRED TO LCP-43200.
- POWERED FROM LCP-43200.
- * VENDOR SUPPLIED.
- LOCAL OPERATOR PANEL BY VENDOR.
- SOLENOID VALVE CONTROLLED BY LCP-43601/43602 (POLYMER EQUIPMENT CONTROL PANEL).
- BY HVAC/PLUMBING.

THIS DOCUMENT IS AN ELECTRONIC COPY ORIGINAL DOCUMENT WAS ISSUED AND SEALED ON 11/04/2016. THE ORIGINAL DOCUMENT IS STORED AT THE OFFICES OF CH2M HILL ENGINEERS, INC., ENGLEWOOD, CO.

NO.	DATE	DSGN	DR	CHK	REVISION	BY	APVD
1	22 12 16	ADDENDUM NO. 3	E. JOHNSON	E. KRISTEL		L. FOX	E. JOHNSON

PHASE II, 6 MGD EXPANSION
 FOUR MILE CREEK WORTH
 DEPARTMENT OF PUBLIC WORKS
 CITY OF WICHITA, KANSAS

INSTRUMENTATION AND CONTROLS
RDT P&ID

VERIFY SCALE	BAR IS ONE INCH ON ORIGINAL DRAWING.
DATE	NOVEMBER 2016
PROJ	496312
DWG	090-N-0018
SHEET	147 of 314

GENERAL NOTES

- BLOWER MODIFICATION BY UNITED BLOWER PER SCOPE IN APPENDIX C.
- MODBUS TCP/IP TO IMUX 43901-RIO.

THIS DOCUMENT IS AN ELECTRONIC COPY. ORIGINAL DOCUMENT WAS ISSUED AND SEALED ON 11/04/2016. THE ORIGINAL DOCUMENT IS STORED AT THE OFFICES OF CH2M HILL ENGINEERS, INC., ENGLEWOOD, CO.

NO.	1	DATE	22 12 16	ADDENDUM NO.	3	REVISION	CHK	APVD	11/04/2016
DSGN							E. JOHNSON	L. FOX	E. JOHNSON

PHASE II, 6 MGD EXPANSION
FOUR MILE CREEK WOLF
DEPARTMENT OF PUBLIC WORKS
CITY OF WICHITA, KANSAS

INSTRUMENTATION AND CONTROLS
BLOWERS P&ID

VERIFY SCALE	BAR IS ONE INCH ON ORIGINAL DRAWING.
DATE	NOVEMBER 2016
PROJ	496312
DWG	090-N-0019
SHEET	148 of 314

BIDDING SET

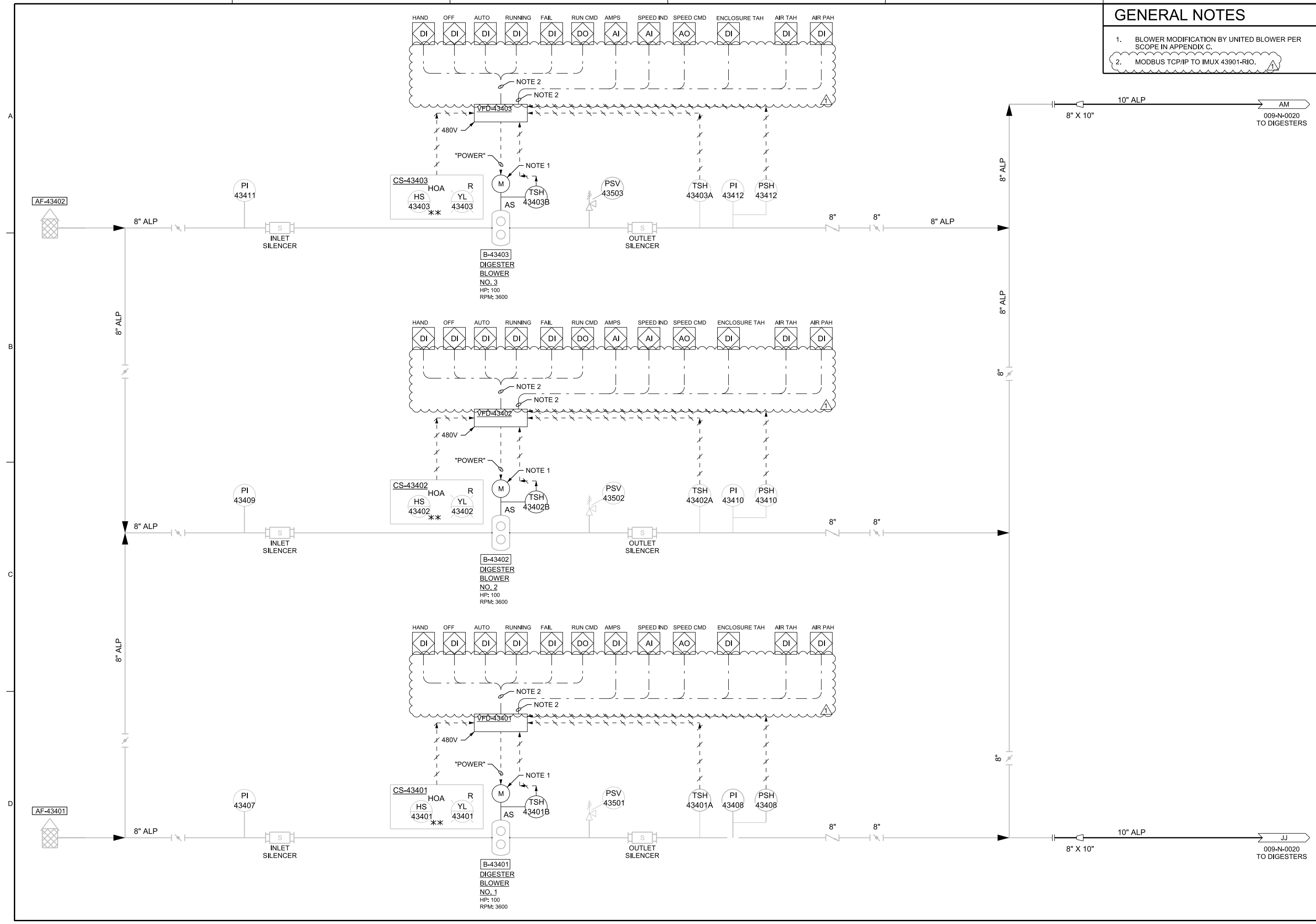

GENERAL NOTES

1. ALL I/O ON THIS DRAWING WIRES TO LCP-43500 EXCEPT AS NOTED.
2. ALL MOTORS ARE POWERED FROM LCP-43500.
3. * VENDOR SUPPLIED.
4. LOCAL OPERATOR PANEL BY VENDOR.
5. FSH SUPPLIED BY SHOWER SUPPLIER.
6. BY HVAC/PLUMBING.

THIS DOCUMENT IS AN ELECTRONIC COPY. ORIGINAL DOCUMENT WAS ISSUED AND SEALED ON 11/04/2016. THE ORIGINAL DOCUMENT IS STORED AT THE OFFICES OF CH2M HILL ENGINEERS, INC., ENGLEWOOD, CO.

NO.	DATE	BY	APVD
1	22 12 16	ADDENDUM NO. 3	
REVISION	CHK	APVD	
DR	E. JOHNSON		
	E. KRISTEL		
	L. FOX		

PHASE II, 6 MGD EXPANSION
FOUR MILE CREEK WORTH
DEPARTMENT OF PUBLIC WORKS
CITY OF WICHITA, KANSAS

INSTRUMENTATION AND CONTROLS
SOLIDS DEWATERING P&ID

VERIFY SCALE	DATE	NOVEMBER 2016
BAR IS ONE INCH ON ORIGINAL DRAWING.	PROJ	496312
	DWG	090-N-0021
	SHEET	150 of 314

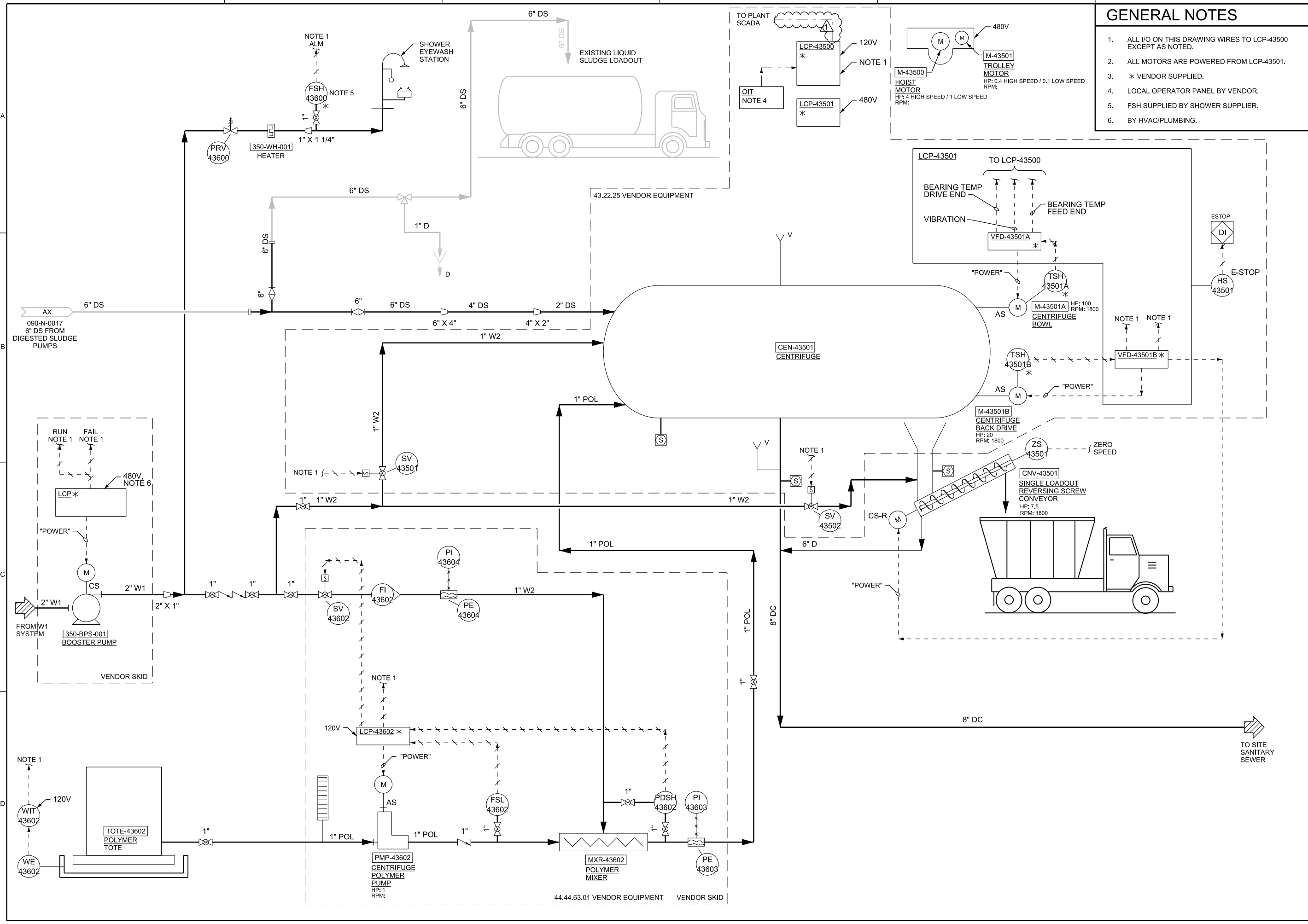

BIDDING SET

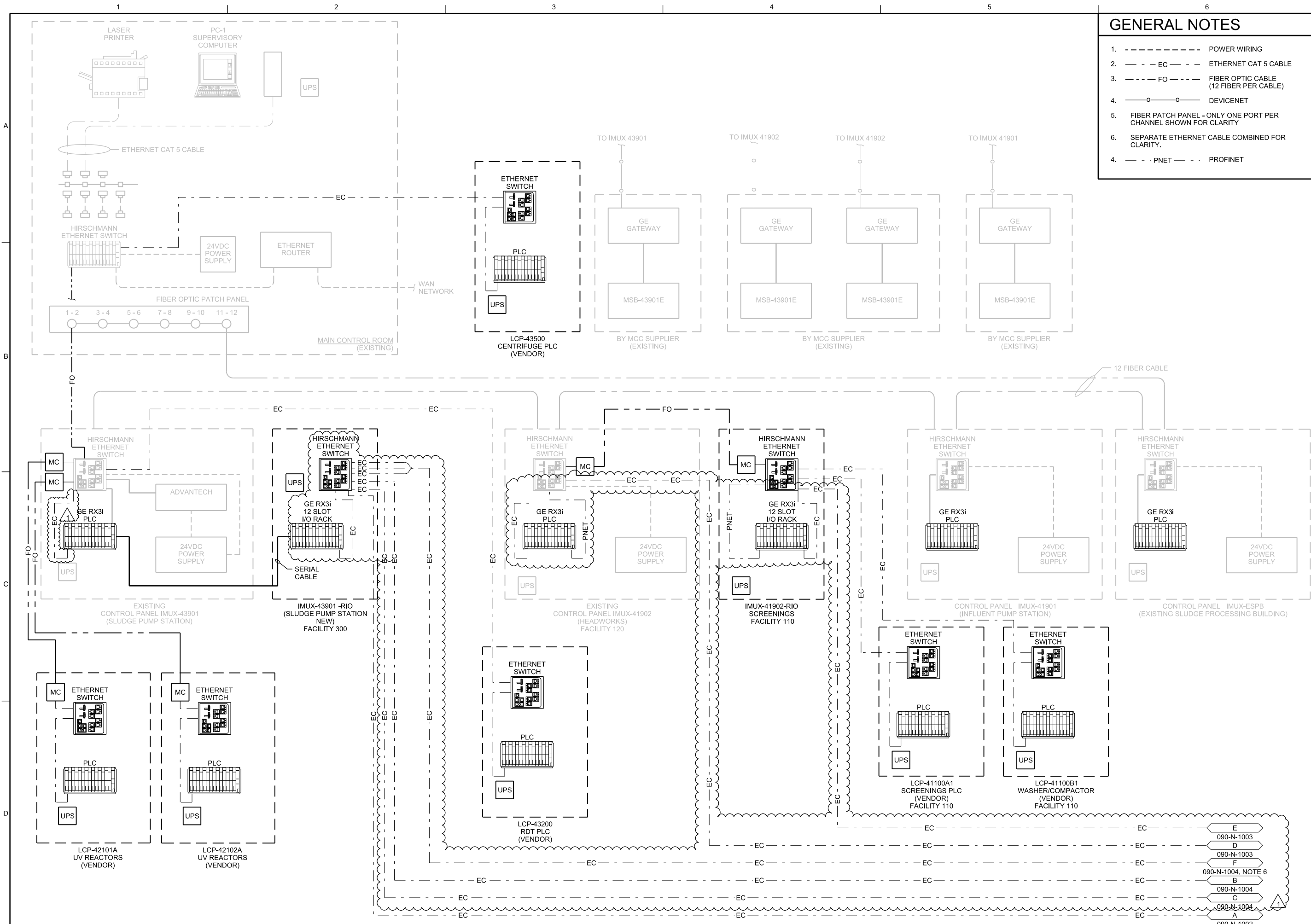

- ### GENERAL NOTES
- POWER WIRING
 - EC --- ETHERNET CAT 5 CABLE
 - FO --- FIBER OPTIC CABLE (12 FIBER PER CABLE)
 - PNET --- PROFINET
 - O --- DEVICENET
 - FIBER PATCH PANEL - ONLY ONE PORT PER CHANNEL SHOWN FOR CLARITY
 - SEPARATE ETHERNET CABLE COMBINED FOR CLARITY.

THIS DOCUMENT IS AN ELECTRONIC COPY ORIGINAL DOCUMENT WAS ISSUED AND SEALED ON 11/04/2016. THE ORIGINAL DOCUMENT IS STORED AT THE OFFICES OF CH2M HILL ENGINEERS, INC., ENGLEWOOD, CO.

NO.	1	DATE	22 12 16	ADDENDUM NO.	3	REVISION	CHK	APVD	E. JOHNSON
DSGN									
DR									

PHASE II, 6 MGD EXPANSION
FOUR MILE CREEK WRF
DEPARTMENT OF PUBLIC WORKS
CITY OF WICHITA, KANSAS

INSTRUMENTATION AND CONTROLS
NETWORK DIAGRAM 1

VERIFY SCALE	
DATE	NOVEMBER 2016
PROJ	496312
DWG	090-N-1001
SHEET	152 of 314

1

2

3

4

5

6

GENERAL NOTES

- 1. - - - - - POWER WIRING
- 2. - - - - - ETHERNET CAT 5 CABLE
- 3. - - - - - FIBER OPTIC CABLE (12 FIBER PER CABLE)
- 4. ○ - ○ DEVICENET
- 5. SEPARATE ETHERNET CABLE COMBINED FOR CLARITY.

THIS DOCUMENT IS AN ELECTRONIC COPY. ORIGINAL DOCUMENT WAS ISSUED AND SEALED ON 11/04/2016. THE ORIGINAL DOCUMENT IS STORED AT THE OFFICES OF CH2M HILL ENGINEERS, INC., ENGLEWOOD, CO.

NO.	1	DATE	22 12 16	ADDENDUM NO.	3	REVISION	CHK	APVD	E. JOHNSON
DGN									
DR									

PHASE II, 6 MGD EXPANSION
FOUR MILE CREEK WQRF
DEPARTMENT OF PUBLIC WORKS
CITY OF WICHITA, KANSAS

ch2m
INSTRUMENTATION AND CONTROLS
NETWORK DIAGRAM 3

VERIFY SCALE	BAR IS ONE INCH ON ORIGINAL DRAWING.
DATE	SEPTEMBER 2016
PROJ	496312
DWG	090-N-1004
SHEET	of

BIDDING SET

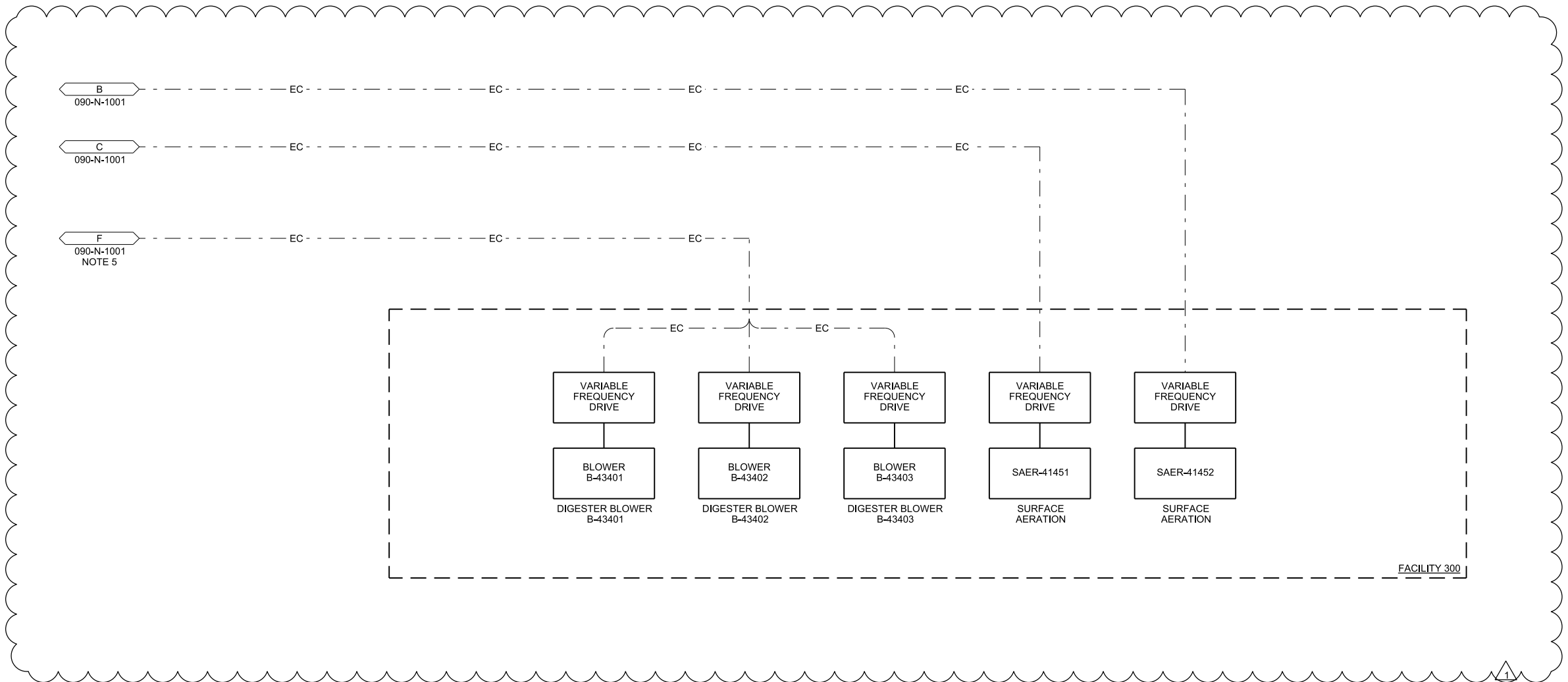

FACILITY 300

1

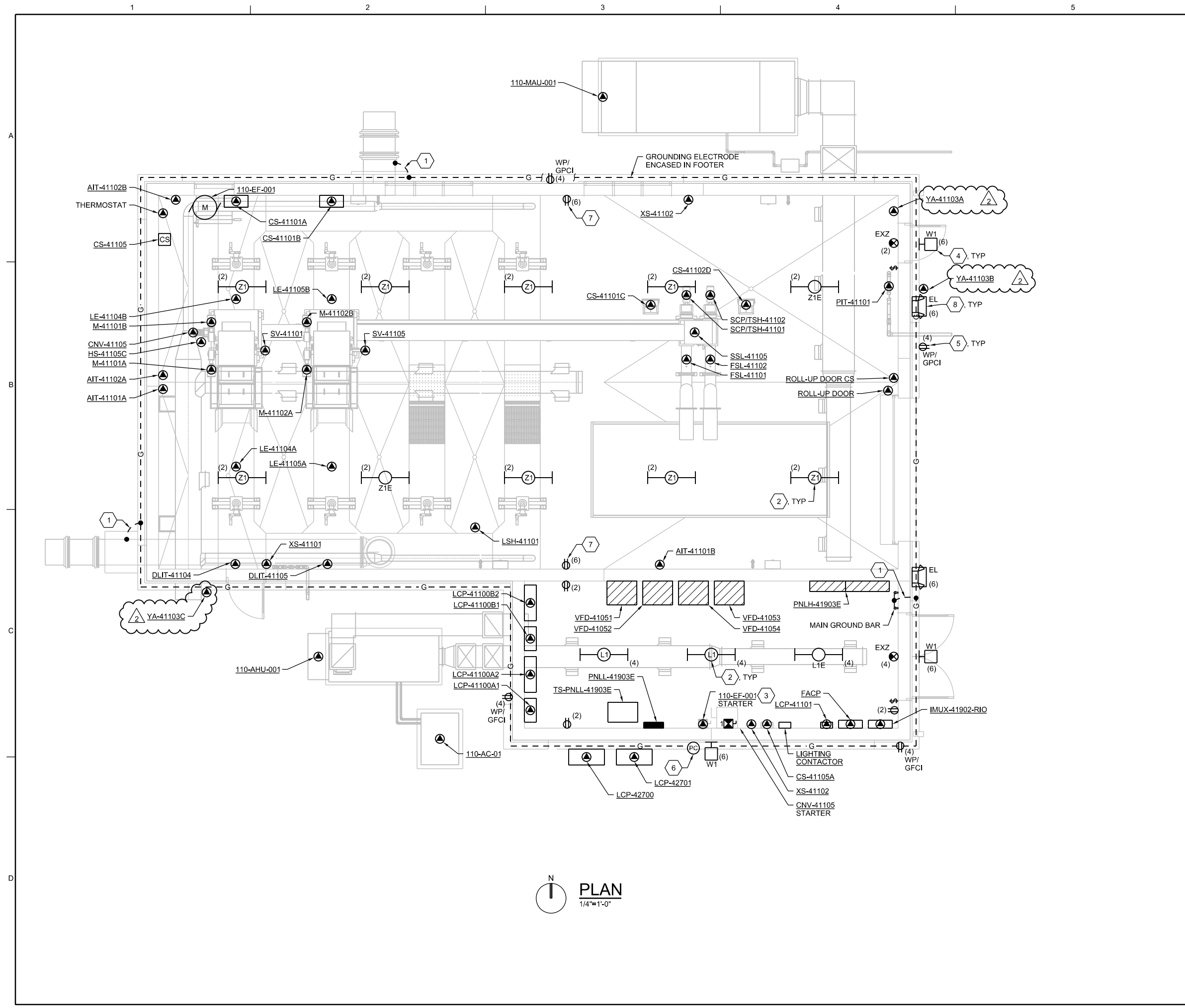

GENERAL NOTES

- ALL LUMINAIRES AT THIS FACILITY ARE FED FROM PNLH-41903E. ALL RECEPTACLES AT THIS FACILITY ARE FED FROM PNL-41903E. SEE PANEL SCHEDULES AND BLOCK DIAGRAMS FOR FURTHER INFORMATION.

THIS DOCUMENT IS AN ELECTRONIC COPY. ORIGINAL DOCUMENT WAS ISSUED AND SEALED ON 11/04/2016. THE ORIGINAL DOCUMENT IS STORED AT THE OFFICES OF CH2M HILL ENGINEERS, INC., ENGLEWOOD, CO.

SHEET KEYNOTES

- PROVIDE 2/0 AWG BONDING CONDUCTOR TO MAIN GROUND CONDUCTOR, WHICH IS EMBEDDED IN THE FOUNDATION FOOTER.
- MOUNT ALL LUMINAIRES THIS ROOM 15FT AFF, UNLESS OTHERWISE NOTED.
- COMBINATION STARTER-DISCONNECT PROVIDED BY DIVISION 23, BUILDING MECHANICAL. INSTALLATION BY DIVISION 26, ELECTRICAL.
- MOUNT EXTERIOR LUMINAIRES 8FT ABOVE FINISHED GRADE.
- MOUNT EXTERIOR RECEPTACLES 3FT ABOVE FINISHED GRADE.
- MOUNT PHOTOCELL AS HIGH ON EXTERIOR WALL AS POSSIBLE, MINIMUM 10FT ABOVE GRADE.
- 20A, 1P, 120VAC, DUPLEX RECEPTACLE, CLASS 1 DIV 2 RATED, HUBBELL #UGRA20231. USE HUBBELL 'SWB' SERIES BACK BOXES. MOUNT AT 48 INCHES AFF.
- MOUNT EMERGENCY LIGHTING AS HIGH ON WALL AS POSSIBLE, NOT TO EXCEED 15 FT. FIELD-ADJUST LAMPS FOR MAXIMUM LIGHTING COVERAGE.
- PROVIDE CONTROL WIRING TO FINAL SAMPLER LOCATION IN SCREEN ROOM, AS SELECTED BY OWNER

NO.	DATE	DR	CHK	REVISION	BY	APVD
2	12/23/16	J. LANDMAN	A. CUGLIAT	ADDENDUM NO. 3	JL	M. GROSS
1	12/16/16	J. LANDMAN	A. CUGLIAT	ADDENDUM NO. 2	JK	M. GROSS

PHASE II, 6 MGD EXPANSION
FOUR MILE CREEK WORK
DEPARTMENT OF PUBLIC WORKS
CITY OF WICHITA, KANSAS

ch2m
SCREENING FACILITY
ELECTRICAL
PLAN

VERIFY SCALE	BAR IS ONE INCH ON ORIGINAL DRAWING.
DATE	NOVEMBER 2016
PROJ	496312
DWG	110-E-2001
SHEET	197 of 314